

Neosys Technology Inc.

Nuvo-11531/ 11588 Series

User Manual

Revision 1.0

Table of Contents

Table of Contents	2
Legal Information	4
Declaration of Conformity	5
Copyright Notice	6
Safety Precautions	7
Service and Maintenance	9
Avertissement concernant les piles	9
Hot Surface Warning.....	10
Surface chaude	10
Battery Warning.....	11
Entretien et ecessarie	11
ESD Precautions	12
Précautions ecessaries de décharge électrostatique (ESD)	12
Restricted Access Location	13
Lieu d'accès restreint	13
About This Manual	14

1 Introduction

1.1 Product Specifications.....	17
1.1.1 Nuvo-11531 Specifications.....	17
1.1.2 Nuvo-11588 Specifications.....	19
1.2 Nuvo-11531/ 11588 Series Dimensions.....	21
1.2.1 Nuvo-11531/ 11588 Front Panel View	21
1.2.2 Nuvo-11531/ 11588 Rear Panel View	21
1.2.3 Nuvo-11588 SlimSAS Port Side View	22
1.2.4 Nuvo-11531/ 11588 Top View.....	22
1.2.5 Nuvo-11531/ 11588 Bottom View	23

2 System Overview

2.1 Packing List	24
2.1.1 Nuvo-11531 Series Packing List	24
2.1.2 Nuvo-11588 Series Packing List	24
2.2 Nuvo-11531/ 11588 Front Panel I/O	25
2.2.1 3-Pin Pluggable Terminal Block	26
2.2.2 System Status LED Indicator	27
2.2.3 USB3.2 Gen1 Port	27
2.2.4 HDMI™ Port.....	28
2.2.5 CMOS Button.....	29
2.2.6 2.5Gb Ethernet Port	30
2.2.7 Power Button	31
2.2.8 Reset Button	31
2.2.9 2.5" Easy Swap Tray	32
2.3 Rear Panel I/O	33
2.3.1 Digital Input/ Output	34
2.3.2 COM 1 Port	37
2.3.3 COM2/3/4 Port	38
2.3.4 USB 2.0 Port	39
2.3.5 DisplayPort	40
2.4 SlimSAS 8i SFF-8654 Port (Nuvo-11588 Only)	41
2.5 Internal I/O Functions.....	43
2.5.1 SODIMM DRAM Slot	43
2.5.2 mini-PCIe Socket & Pin Definition	44
2.5.3 M.2 2230 (E Key) Slot & Pin Definition	46
2.5.4 SATA Ports.....	48
2.5.5 Ignition Control Switch (Optional).....	49
2.5.6 M.2 2280 (M Key) Slot for NVMe SSD	50
2.5.7 DIP Switch SlimSAS 8i Port	52

3	System Installation	
3.1	Disassembling the System	54
3.2	Installing Internal Components	56
3.2.1	CPU Installation for Barebone System	56
3.2.2	Remove and Replace the Existing CPU	63
3.2.3	DDR5 SO-DIMM Installation	71
3.2.4	Mini-PCIe Module, SIM Card and Antenna Installation	77
3.2.5	M.2 2230 E-Key Module Installation	79
3.2.6	M.2 2280 NVMe SSD Installation	81
3.3	Installing the System Enclosure	83
3.4	2.5" Easy Swap Tray HDD/ SSD Installation	85
3.5	Ethernet/ PoE+ Port Panel Screw Fix	87
3.6	Wall Mount Bracket/ DIN-rail Installation	88
3.6.1	Wall Mount Bracket Installation	88
3.6.2	DIN-rail Installation (Optional)	89
3.6.3	Fan Kit Installation (Optional)	90
3.7	Powering On the System	96
3.7.1	Powering On Using the Power Button	96
3.7.2	Powering On Using External Non-latched Switch	97
3.7.3	Powering On Using Wake-on-PME (Wake-on-LAN)	98
4	System Configuration	
4.1	BIOS Settings	101
4.1.1	COM Port Configuration	102
4.1.2	COM Port High Speed Mode	103
4.1.3	COM2/3/4 Port Configuration	104
4.1.4	TPM Availability	105
4.1.5	Power over Ethernet (PoE) Power Enable	106
4.1.6	Auto Wake on S5	108
4.1.7	Power On After Power Failure Option	109
4.1.8	Power & Performance (CPU SKU Power Configuration)	110
4.1.9	Wake on PME (Wake-On-LAN) Option	111
4.1.10	Boot Menu	112
4.1.11	Add Boot Options (Position New Boot Device)	114
4.1.12	Watchdog Timer for Booting	115
5	OS Support and Driver Installation	
5.1	Operating System Compatibility	116
5.2	System Driver Installation	117
5.3	Driver Installation for Watchdog Timer Control	117
Appendix A Using WDT & DIO		
	WDT and DIO Library Installation	119
	WDT Functions	122
	InitWDT	122
	SetWDT	122
	StartWDT	123
	ResetWDT	123
	StopWDT	123
Appendix B PoE On/ Off Control		
	GetStatusPoEPort	124
	EnablePoEPort	125
	DisablePoEPort	126

Legal Information

All Neosys Technology Inc. products shall be subject to the latest Standard Warranty Policy

Neosys Technology Inc. may modify, update or upgrade the software, firmware or any accompanying user documentation without any prior notice. Neosys Technology Inc. will provide access to these new software, firmware or documentation releases from download sections of our website or through our service partners.

Before installing any software, applications or components provided by a third party, customer should ensure that they are compatible and interoperable with Neosys Technology Inc. product by checking in advance with Neosys Technology Inc.. Customer is solely responsible for ensuring the compatibility and interoperability of the third party's products. Customer is further solely responsible for ensuring its systems, software, and data are adequately backed up as a precaution against possible failures, alternation, or loss.

For questions in regards to hardware/ software compatibility, customers should contact Neosys Technology Inc. sales representative or technical support.

To the extent permitted by applicable laws, Neosys Technology Inc. shall NOT be responsible for any interoperability or compatibility issues that may arise when (1) products, software, or options not certified and supported; (2) configurations not certified and supported are used; (3) parts intended for one system is installed in another system of different make or model.

Declaration of Conformity

FCC

This equipment has been tested and found to comply with the limits for a Class A digital device, pursuant to part 15 of the FCC Rules. These limits are designed to provide reasonable protection against harmful interference when the equipment is operated in a commercial environment. This equipment generates, uses, and can radiate radio frequency energy and, if not installed and used in accordance with the instruction manual, may cause harmful interference to radio communications. Operation of this equipment in a residential area is likely to cause harmful interference in which case the user will be required to correct the interference at own expense.

CE

The product(s) described in this manual complies with all applicable European Union (CE) directives if it has a CE marking. For computer systems to remain CE compliant, only CE-compliant parts may be used. Maintaining CE compliance also requires proper cable and cabling techniques.

Copyright Notice

All rights reserved. This publication may not be reproduced, transmitted, transcribed, stored in a retrieval system, or translated into any language or computer language, in any form or by any means, electronic, mechanical, magnetic, optical, chemical, manual or otherwise, without the prior written consent of Neosys Technology, Inc.

Disclaimer

This manual is intended to be used as an informative guide only and is subject to change without prior notice. It does not represent commitment from Neosys Technology Inc. Neosys Technology Inc. shall not be liable for any direct, indirect, special, incidental, or consequential damages arising from the use of the product or documentation, nor for any infringement on third party rights.

Patents and Trademarks

Neosys, the Neosys logo, Expansion Cassette, MezIO™ are registered patents and trademarks of Neosys Technology, Inc.

Windows is a registered trademark of Microsoft Corporation.

Intel®, Core™ are registered trademarks of Intel Corporation

NVIDIA® is a registered trademark of NVIDIA Corporation

All other names, brands, products or services are trademarks or registered trademarks of their respective owners.

Safety Precautions

- Read these instructions carefully before you install, operate, or transport the system.
- Install the system or DIN rail associated with, at a sturdy location
- Install the power socket outlet near the system where it is easily accessible
- Secure each system module(s) using its retaining screws
- Place power cords and other connection cables away from foot traffic. Do not place items over power cords and make sure they do not rest against data cables
- Shutdown, disconnect all cables from the system and ground yourself before touching internal modules
- Ensure that the correct power range is being used before powering the device
- Should a module fail, arrange for a replacement as soon as possible to minimize down-time
- By means of a power cord connected to a socket-outlet with earthing connection
- If the system is not going to be used for a long time, disconnect it from mains (power socket) to avoid transient over-voltage

Mesures de sécurité

- Lire attentivement ces directives avant d'installer, d'utiliser ou de transporter le système.
- Installer le système ou la barrette DIN qui lui est associée, à un endroit solide
- Installer la prise de courant près du système et pour qu'elle soit facilement accessible
- Fixer chaque module du système à l'aide de ses vis de fixation
- Éloigner de la circulation piétonne les cordons d'alimentation et autres câbles de connexion. Ne jamais placer d'objets sur les cordons d'alimentation et s'assurer qu'ils ne reposent pas contre les câbles de données
- Avant de toucher les modules internes, arrêter, débrancher tous les câbles du système et raccordez-vous à la terre
- S'assurer que la bonne plage de puissance est utilisée avant d'alimenter l'appareil
- Prévoir un remplacement dès que possible en cas de défaillance d'un module, afin de minimiser les temps d'arrêt
- Au moyen d'un cordon d'alimentation branché à une prise de courant avec mise à la terre (MALT)
- Si le système ne sera pas être utilisé pendant une période prolongée, le débrancher du réseau (prise de courant) pour éviter une surtension transitoire

Service and Maintenance

- ONLY qualified personnel should service the system
- Shutdown the system, disconnect the power cord and all other connections before servicing the system
- When replacing/ installing additional components (expansion card, memory module, etc.), insert them as gently as possible while assuring proper connector engagement

Avertissement concernant les piles

- Les piles risquent d'exploser si 9ece sont mal installées.
- Ne jamais essayer de recharger, d'ouvrir de force ou de chauffer les piles.
- Remplacer les piles uniquement avec le 9ece type ou l'équivalent recommandé par le fabricant.

Hot Surface Warning



HOT SURFACE. DO NOT

TOUCH. "ATTENTION: Surface chaude. Ne pas toucher."

WARNING!

Components/ parts inside the equipment may be hot to touch!

Please wait one-half hour after switching off before handling parts.

Surface chaude

AVERTISSEMENT : *SURFACE CHAUDE. NE PAS TOUCHER.*

Les composants et l'accès à l'intérieur de l'équipement peuvent être chauds au toucher. Après l'arrêt, attendre au moins 30 minutes pour que le système refroidisse avant d'effectuer l'entretien.

- Respecter les règles de sécurité et d'entretien mentionnées au début du guide d'utilisation!

Battery Warning

Caution!



- Batteries are at risk of exploding if incorrectly installed
- Do not attempt to recharge, force open, or heat the battery
- Replace the battery only with the same or equivalent type recommended by the manufacturer

Entretien et 11ecessarie

- La réparation du système ne peut être effectuée que par du personnel qualifié
- Avant de réparer le système, arrêter le système, débrancher le cordon d'alimentation et toutes les autres connexions
- Lors du remplacement ou de l'installation de composants supplémentaires (carte d'extension, module de mémoire, etc.), les insérer le plus doucement possible tout en s'assurant que les connecteurs sont bien engagés jusqu'au bout

ESD Precautions

- Handle add-on module, motherboard by their retention screws or the module's frame/ heat sink. Avoid touching the PCB circuit board or add-on module connector pins
- Use a grounded wrist strap and an anti-static work pad to discharge static electricity when installing or maintaining the system
- Avoid dust, debris, carpets, plastic, vinyl and 12ecessari in your work area.
- Do not remove any module or component from its anti-static bag before installation

Précautions 12ecessaries de décharge électrostatique (ESD)

- Tenir le module complémentaire et la carte mère par leurs vis de rétention ou le châssis/dissipateur de chaleur du module. Éviter de toucher la carte de circuit imprimé ou les broches du connecteur du module complémentaire
- Afin de décharger l'électricité statique, utiliser une dragonne mise à la terre et un tapis de travail antistatique lors de l'installation ou de l'entretien du système
- Éviter la poussière, les débris, les tapis, le plastique, le vinyle et la mousse de polystyrène dans votre zone de travail.
- Ne retirer aucun module ou composant de son sac antistatique avant l'installation

Restricted Access Location

The controller is intended for installation only in certain environments where both of the following conditions apply:

- Access can only be gained by QUALIFIED SERVICE PERSONNEL who have been instructed on the reasons for restrictions applied to the location and any precautions that shall be taken
- Access is through the use of a TOOL, lock and key, or other means of security, and is controlled by the authority responsible for the location

Lieu d'accès restreint

Le contrôleur doit être installé uniquement dans les environnements où les deux conditions suivantes sont présentes :

- Le lieu ne peut être accédé que par du PERSONNEL TECHNIQUE QUALIFIÉ informé des raisons des restrictions appliquées à l'emplacement et des précautions à prendre
- L'accès est contrôlé par l'autorité responsable de l'emplacement et se fait au moyen d'un OUTIL, d'une serrure et d'une clé ou d'autres moyens de sécurité

About This Manual

This manual introduces Neosys Nuvo-11531/ 11588 series, a low profile form factor rugged embedded platform featuring Intel® Core Ultra 200S hybrid performance/ efficient core processors.

Revision History

Version	Date	Description
1.0	Sep. 2025	Initial release

1 Introduction

The Nuvo-11531 is one of the most compact fanless embedded AI computers powered by the Intel® Core™ Ultra 200S series. Its low-profile 212 x 165 x 63 mm footprint makes it ideal for constrained spaces, including robotic arms, AMRs, machine vision systems, and roadside cabinets.

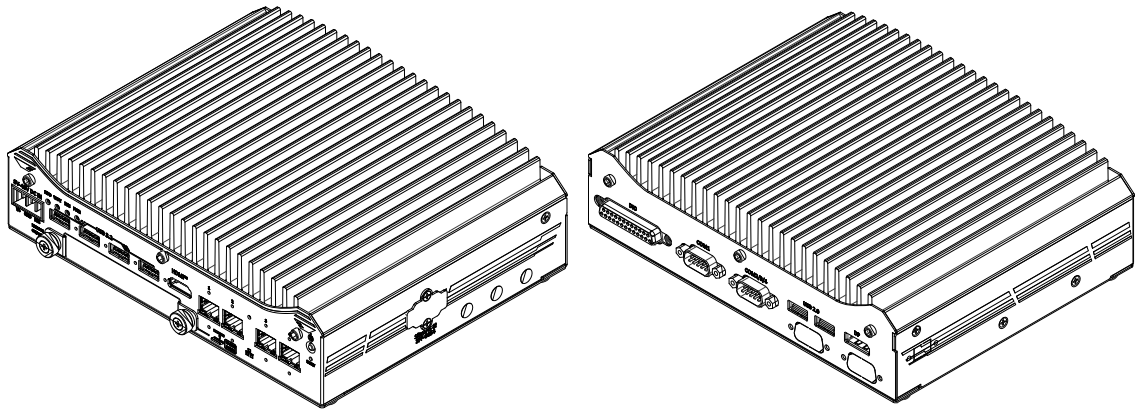

Despite its compact size, the Nuvo-11531 does not compromise on performance. Leveraging TSMC's advanced 3nm process, Intel® Core™ Ultra 200 processors can offer nearly 120% the performance while consuming only 80% of the power*. Furthermore, with the new NPU and integrated GPU, Intel® Core™ Ultra 200 processors deliver up to 36 TOPS, enhancing AI inspection capabilities for existing rule-based computer vision algorithms.

Designed for diverse edge applications—such as machine vision, AMRs, and smart automation—the Nuvo-11531 offers versatile sensor connections. It features four PoE+ 2.5GbE ports and four USB 3.2 Gen1 ports for industrial/ security cameras or LiDAR, along with multiple isolated DIO and dual COM ports for communication with external devices. Internally, it includes one M.2 E-key slot for Wi-Fi modules and two mPCIe slots for flexible I/O expansion, supporting 5G/4G modules, COM ports, CAN bus, or additional GbE ports. For data storage, it provides an internal Gen4 x4 M.2 NVMe slot for the OS and an easy-swappable 2.5" SSD tray for data logging. The wide DC input and optional ignition power control are ideal for battery-powered applications, such as robotics and in-vehicle usage. Additionally, the Nuvo-11588 variant features a SlimSAS connector with PCIe Gen4 x8 bandwidth for external NVMe, U.2 storage, industrial PCIe cameras, or GPUs.

As compact embedded computers, the Nuvo-11531 and Nuvo-11588 deliver exceptional computing performance and extensive I/O connectivity. They are well-suited for various

industrial and edge applications, including smart factories, autonomous logistics, smart cities, and robotics—particularly where installation space is limited.

1.1 Product Specifications

1.1.1 Nuvo-11531 Specifications

System Core	
Processor	Supports Core™ Ultra 200S series CPU (LGA 1851 socket, 65W/ 35W TDP) - Intel® Core™ Ultra 9 285/285T - Intel® Core™ Ultra 7 265/265T - Intel® Core™ Ultra 5 245/245T
Chipset	Intel® H810 platform controller hub
Graphics	Integrated Intel Xe LPG graphics
AI Engine	Integrated neural processing unit
Memory	Up to 64 GB DDR5 6400 SDRAM (single SODIMM slot)
TPM	fTPM 2.0 (standard)/ dTPM 2.0 (optional)
I/O Interface	
Ethernet port	4x 2.5GBASE-T Ethernet ports with screw-lock by Intel® I226 GbE controllers. Port 4 supports Wake-on-LAN (WOL)
PoE+	Optional IEEE 802.3at PoE+ PSE for 4x 2.5GbE (100W total power budget)
USB	4x USB 3.2 Gen1 (5Gbps) ports with screw-lock 2x USB 2.0 ports
Video Port (Integrated graphics)	1x HDMI connector, supporting 3840 x 2160 resolution 1x DisplayPort connector, supporting 3840 x 2160 resolution (The DisplayPort does not support DP++. Use an active DP-to-HDMI adaptor for HDMI output)
Serial Port	1x software-programmable RS-232/ 422/ 485 ports (COM1) 3x 3-wire RS-232 ports (COM2/ COM3/ COM4) or 1x RS-422/ 485 port (COM2)
Isolated digital input/ output	4-CH isolated DI and 4-CH isolated DO
Storage Interface	
SATA HDD	1x easy swappable 2.5" HDD/ SSD tray (up to 7mm thickness)
M.2 M	1x M.2 2280 M key socket (PCIe Gen4x4) for NVMe SSD
Internal Expansion Bus	
M.2 E	1x M.2 2230 E key socket for WiFi module
Mini PCI-E	2x full-size mini PCI Express sockets with internal SIM sockets
Power Supply	

DC Input	1x 3-pin pluggable terminal block for 8V to 48V DC input with optional ignition power control*	
Maximum Power Consumption	Ultra 7 265 (35W)	Ultra 9 285 (35W)
	67.4W (PL2) @ 12V	67.9W (PL2) @ 12V
	70.1W (PL2) @ 24V	69.6W (PL2) @ 24V
	74.8W (PL2) @ 48V	73.7W (PL2) @ 48V
	Ultra 7 265 (65W)	Ultra 9 285 (65W)
	120.6W (PL2) @ 12V	123.5W (PL2) @ 12V
	123.0W (PL2) @ 24V	121.9W (PL2) @ 24V
126.4W (PL2) @ 48V	127.0W (PL2) @ 48V	
	Ultra 7 265 (Max SKU)	Ultra 9 285 (Max SKU)
	189.8W (PL2) @ 12V	189.1W (PL2) @ 12V
	178.7W (PL2) @ 24V	184.4W (PL2) @ 24V
	183.4W (PL2) @ 48V	188.2W (PL2) @ 48V
Mechanical		
Dimension	212 mm (W) x 165 mm (D) x 63 mm (H)	
Weight	2.2Kg (excluding wall mount kits)	
Mounting	Wall-mount (standard) or DIN-rail mount (optional)	
Environmental		
Operating Temperature	With 35W CPU -25°C to 60°C ** With 65W CPU (installation of optional fan kit recommended) -25°C to 60°C **/ ***	
Storage Temperature	-40°C to 85°C	
Humidity	10% to 90%, non-condensing	
Vibration	MIL-STD-810H, Method 514.8, Category 4	
Shock	MIL-STD-810H, Method 516.8, Procedure I	
EMC	CE/FCC Class A, according to EN 55032 & EN 55035	

* The maximum input current for each pin is 20A. While using the PoE+ feature, the allowable DC input range is 12V to 48V

** For sub-zero operating temperature, a wide temperature HDD or Solid State Disk (SSD) is required

*** For 65W CPUs, the optional fan kit is recommended for operating at ambient temperatures higher than 50°C

1.1.2 Nuvo-11588 Specifications

System Core	
Processor	Supports Core™ Ultra 200S series CPU (LGA 1851 socket, 65W/ 35W TDP) - Intel® Core™ Ultra 9 285/285T - Intel® Core™ Ultra 7 265/265T - Intel® Core™ Ultra 5 245/245T
Chipset	Intel® Q870 platform controller hub
Graphics	Integrated Intel Xe LPG graphics
AI Engine	Integrated neural processing unit
Memory	Up to 64 GB DDR5 6400 SDRAM (single SODIMM slot)
TPM	fTPM 2.0 (standard)/ dTPM 2.0 (optional)
I/O Interface	
Ethernet port	4x 2.5GBASE-T Ethernet ports with screw-lock by Intel® I226 GbE controllers. Port 4 supports Wake-on-LAN (WOL)
PoE+	Optional IEEE 802.3at PoE+ PSE for 4x 2.5GbE (100W total power budget)
External PCIe connector	1x PCIe Gen4x8 via SlimSAS 8i (SSF-8654) connector
USB	4x USB 3.2 Gen1 (5Gbps) ports with screw-lock 2x USB 2.0 ports
Video Port	1x HDMI connector, supporting 3840 x 2160 resolution 1x DisplayPort connector, supporting 3840 x 2160 resolution (The DisplayPort does not support DP++. Use an active DP-to-HDMI adaptor for HDMI output)
Serial Port	1x software-programmable RS-232/ 422/ 485 ports (COM1) 3x 3-wire RS-232 ports (COM2/ COM3/ COM4) or 1x RS-422/ 485 port (COM2)
Isolated digital input/ output	8-CH isolated DI and 8-CH isolated DO
Storage Interface	
SATA HDD	1x easy swappable 2.5" HDD/ SSD tray (up to 7mm thickness)
M.2 M	1x M.2 2280 M key socket (PCIe Gen4x4) for NVMe SSD
Internal Expansion Bus	
M.2 E	1x M.2 2230 E key socket for WiFi module
Mini PCI-E	2x full-size mini PCI Express sockets with internal SIM sockets
Power Supply	
DC Input	1x 3-pin pluggable terminal block for 8V to 48V DC input with optional ignition

	power control*	
Maximum Power Consumption	Ultra 7 265 (35W)	Ultra 9 285 (35W)
	67.4W (PL2) @ 12V	67.9W (PL2) @ 12V
	70.1W (PL2) @ 24V	69.6W (PL2) @ 24V
	74.8W (PL2) @ 48V	73.7W (PL2) @ 48V
	Ultra 7 265 (65W)	Ultra 9 285 (65W)
	120.6W (PL2) @ 12V	123.5W (PL2) @ 12V
	123.0W (PL2) @ 24V	121.9W (PL2) @ 24V
	126.4W (PL2) @ 48V	127.0W (PL2) @ 48V
	Ultra 7 265 (Max SKU)	Ultra 9 285 (Max SKU)
189.8W (PL2) @ 12V	189.1W (PL2) @ 12V	
178.7W (PL2) @ 24V	184.4W (PL2) @ 24V	
183.4W (PL2) @ 48V	188.2W (PL2) @ 48V	
Mechanical		
Dimension	212 mm (W) x 165 mm (D) x 63 mm (H)	
Weight	2.2Kg (excluding wall mount kits)	
Mounting	Wall-mount (standard) or DIN-rail mount (optional)	
Environmental		
Operating Temperature	With 35W CPU -25°C to 60°C ** With 65W CPU (installation of optional fan kit recommended) -25°C to 60°C **/ ***	
Storage Temperature	-40°C to 85°C	
Humidity	10% to 90%, non-condensing	
Vibration	MIL-STD-810H, Method 514.8, Category 4	
Shock	MIL-STD-810H, Method 516.8, Procedure I	
EMC	CE/FCC Class A, according to EN 55032 & EN 55035	

* The maximum input current for each pin is 20A. While using the PoE+ feature, the allowable DC input range is 12V to 48V

** For sub-zero operating temperature, a wide temperature HDD or Solid State Disk (SSD) is required

*** For 65W CPUs, the optional fan kit is recommended for operating at ambient temperatures higher than 50°C

1.2 Nuvo-11531/ 11588 Series Dimensions

 NOTE

Nuvo-11531/ 11588 share the same dimensions.

All measurements are in millimeters (mm).

The numbers "4.0" represents the height of the rubber stands at 4.0mm.

1.2.1 Nuvo-11531/ 11588 Front Panel View

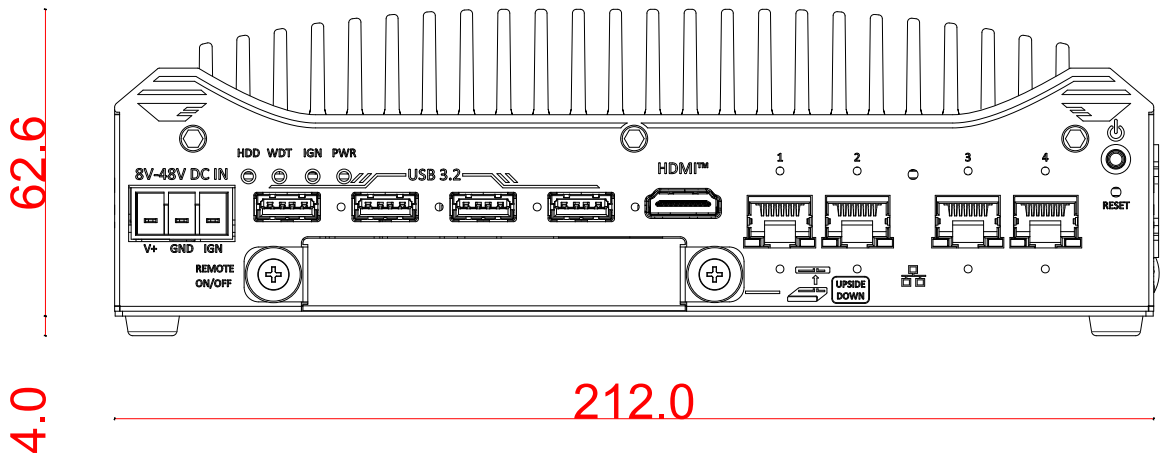

1.2.2 Nuvo-11531/ 11588 Rear Panel View

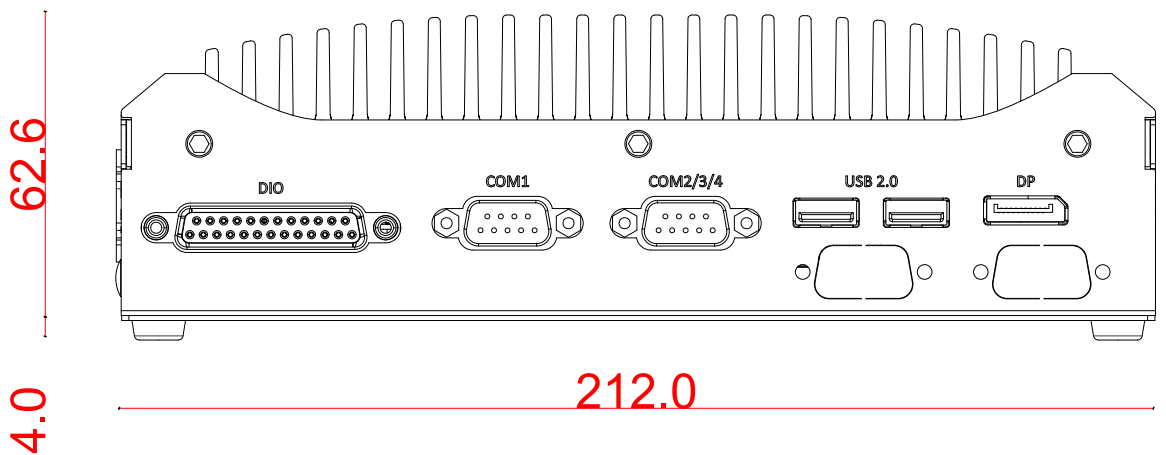

1.2.3 Nuvo-11588 SlimSAS Port Side View

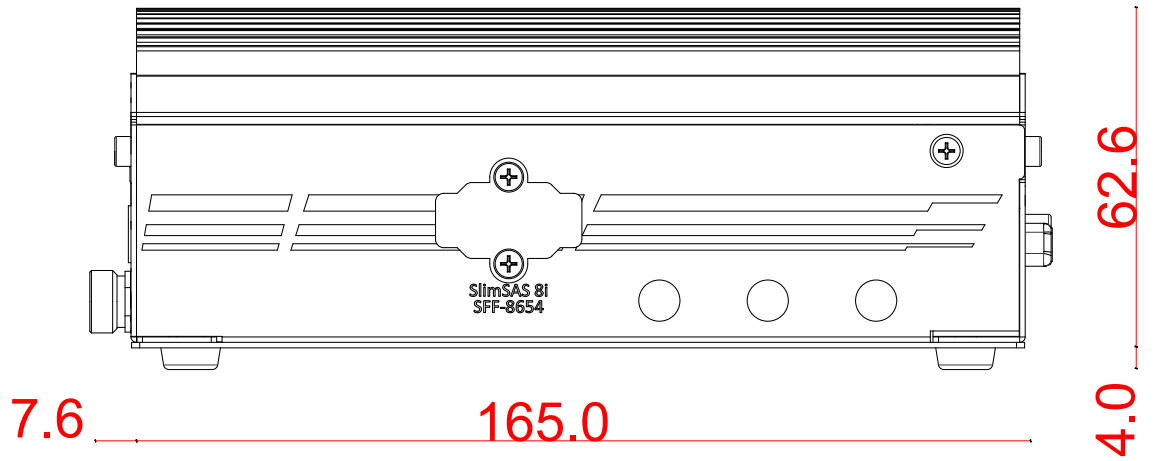

1.2.4 Nuvo-11531/ 11588 Top View

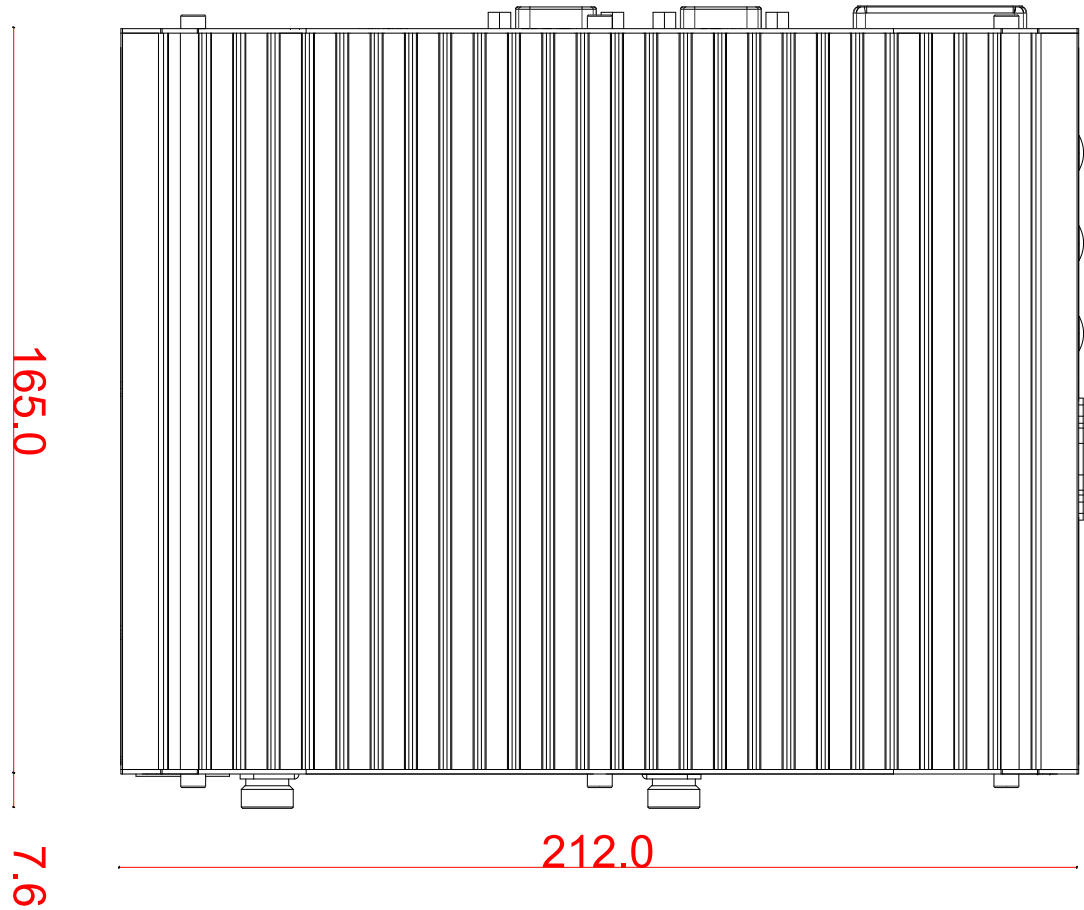

1.2.5 Nuvo-11531/ 11588 Bottom View

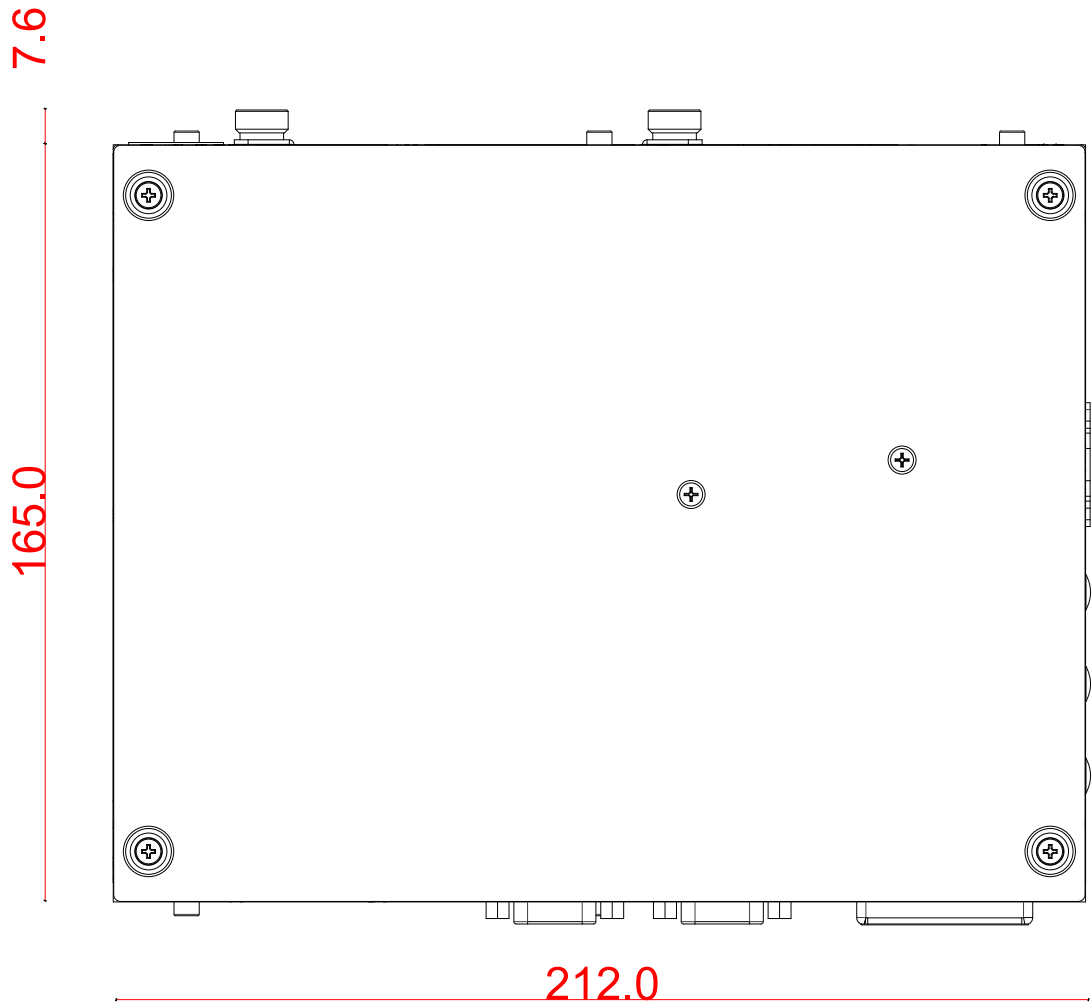

2 System Overview

Upon receiving and unpacking your Nuvo-11531/ 11588 series systems, please check immediately if the package contains all the items listed in the following table. If any item(s) are missing or damaged, please contact your local dealer or Neosys Technology.

2.1 Packing List

2.1.1 Nuvo-11531 Series Packing List



System Pack	Nuvo-11531 Series	Qty
1	Nuvo-11531 series system (If you ordered CPU/ RAM/ HDD, please verify these items)	1
2	Accessory box, which contains <ul style="list-style-type: none"> ● CPU bracket ● Wall-mount bracket ● 3-pin push-in power terminal block ● Screw pack 	1 2 1 1

2.1.2 Nuvo-11588 Series Packing List

System Pack	Nuvo-11588 Series	Qty
1	Nuvo-11588 series system (If you ordered CPU/ RAM/ HDD, please verify these items)	1
2	Accessory box, which contains <ul style="list-style-type: none"> ● CPU bracket ● Wall-mount bracket ● 3-pin push-in power terminal block ● Screw pack 	1 2 1 1

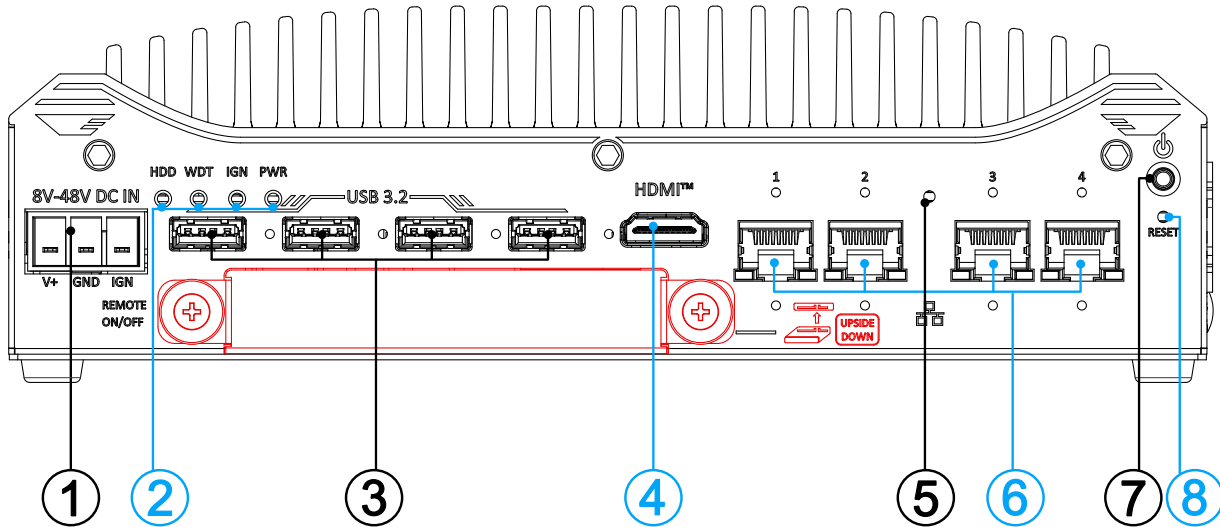
2.2 Nuvo-11531/ 11588 Front Panel I/O



No.	Item	Description
1	3-pin pluggable terminal block	Compatible with DC power input from 8-48V DC input with optional ignition signal input.
2	LED indicators	From left to right, the LEDs are HDD (hard disk drive), WDT (watchdog timer), IGN (ignition control), and PWR (system power).
3	USB3.2 Gen2x1 port	USB3.2 Gen2x1 port offers up to 5Gbps. It is also backwards compatible with USB3.0 and USB2.0
4	HDMI™ port	The HDMI port is a high-resolution graphics/ data port supporting up to 3840 x 2160.
5	CMOS button	The clear CMOS button is used for manually resetting the CMOS to load the default BIOS.
6	2.5Gb Ethernet	2.5Gb Ethernet ports by Intel I226-IT, with optional IEEE 802.3 PoE+ PSE (total 100W power budget)
7	Power button	Use this button to turn on or shutdown the system.
8	Reset button	Use this button to manually reset the system.
	  	2.5" HDD/ SSD easy swap tray

2.2.1 3-Pin Pluggable Terminal Block

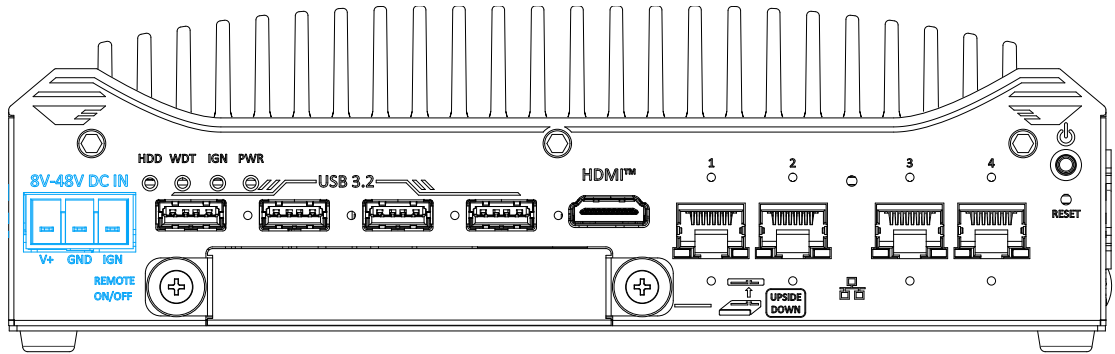

The system accepts a wide range of DC power input from 8 to 48V via a 3-pin pluggable terminal block, which is fit for field usage where DC power is usually provided. The screw clamping mechanism on the terminal block offers connection reliability when wiring DC power. The Remote On/ Off connection allows for external switch extension. It is useful when the system is placed in a cabinet or a not easily accessed location. By connecting the DC in and remote on/ off pins, it activates the “always on” setting that automatically detects the system status to stay powered on.

In addition to DC power input and Remote On/ Off, this terminal block can also accept optional ignition signal input (IGN) for in-vehicle applications.

WARNING

Please make sure the voltage of DC power is correct before you connect it to the system. Supplying a voltage over 48V will damage the system.

2.2.2 System Status LED Indicator

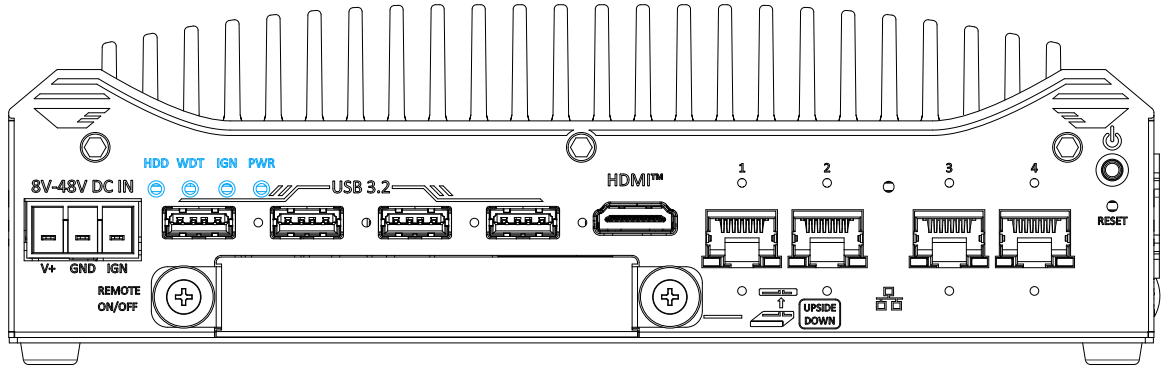

There are four LED indicators on the I/O panel: HDD, WDT, IGN, and PWR. The descriptions of these four LED are listed in the following table.

Indicator	Color	Description
HDD	Red	Hard drive indicator, flashing when hard disk drive is active.
WDT	Yellow	Watchdog timer LED, flashing when WDT is active.
IGN*	Yellow	Ignition signal indicator, lid when IGN is high (12V/ 24V).
PWR	Green	Power indicator, lid when system is on.

*Optional ignition power control

2.2.3 USB3.2 Gen1 Port

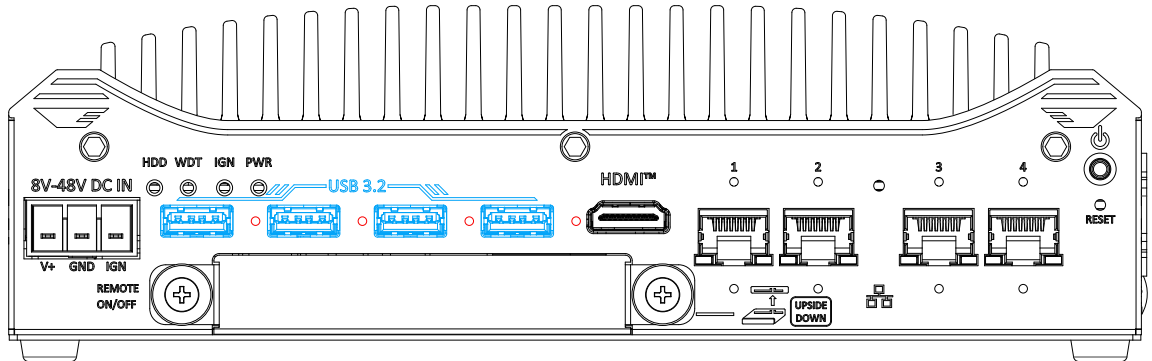

The system's USB 3.2 Gen2x1 ports (5Gbps) are implemented via native xHCI (eXtensible Host Controller Interface) controller and are backward compatible with USB 2.0, USB 1.1 and USB 1.0 devices. UEFI USB is also supported so you can use USB keyboard/mouse in UEFI shell environment. Indicated in **red** is a screw-lock hole for the corresponding USB port.

xHCI driver is supported natively in Windows 10, therefore you do not need to install the xHCI driver prior to utilizing USB functions.

2.2.4 HDMI™ Port

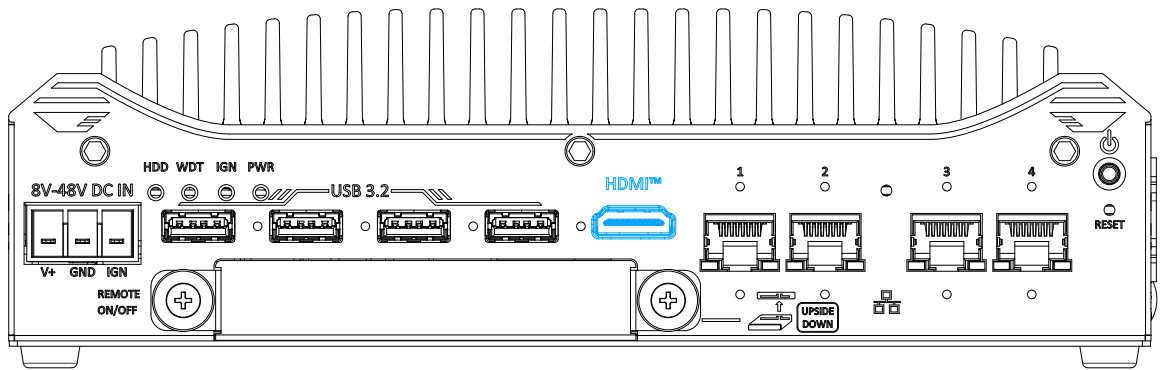

The High-Definition Multimedia Interface (HDMI) port provides uncompressed high-quality digital video and audio transmission between the system and a multimedia display device on a single cable. You can connect to other digital inputs by using a HDMI-to-DVI or HDMI-to-DP cable.



HDMI-to-DP

The system supports dual independent display outputs by connecting display devices to HDMI and DisplayPort connection. To support dual display outputs and achieve best DisplayPort output resolution in Windows, you need to install corresponding graphics drivers. Please refer to section [OS Support and Driver Installation](#) for details.

2.2.5 CMOS Button

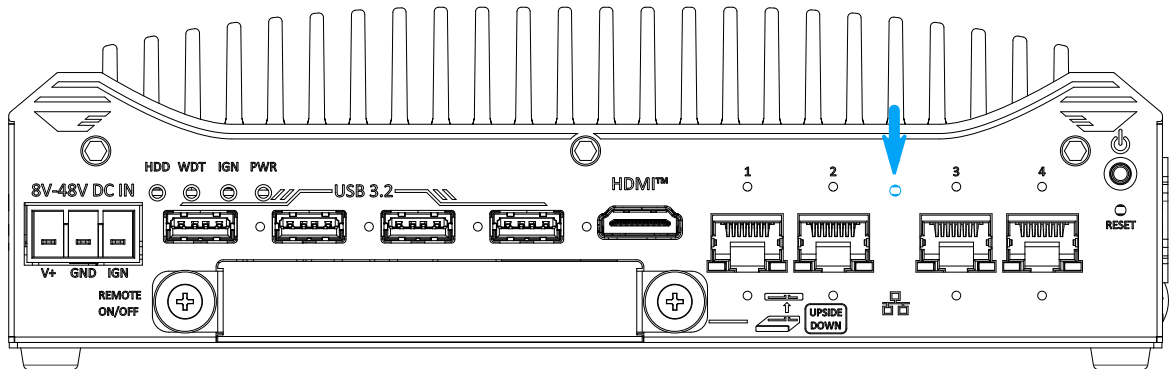

The CMOS button is used to manually reset the motherboard BIOS in case of system halt or malfunction. To avoid unexpected operation, it is purposely placed behind the panel. To reset, disconnect the DC power input, and use the tip of a pen to press and hold for at least 5 seconds to reset the BIOS.



NOTE

You **MUST** disconnect the DC input from the system before resetting the CMOS.



WARNING

Clearing the CMOS will reset all BIOS settings to default and may result in down time!

2.2.6 2.5Gb Ethernet Port

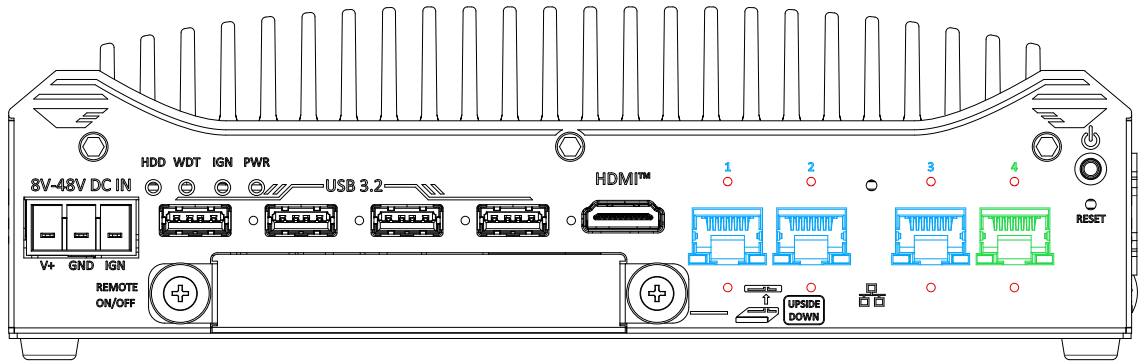

The systems have four 2.5GbE port indicated in **blue and green (Wake-On-LAN supported)**. The ports have the option of IEEE 802.3at PoE+ PSE functionality. All Ethernet ports feature panel screw fix holes for a firm connection (indicated in **red**). The ports are implemented using Intel® I226 controller.

The optional Power over Ethernet (PoE) functionality supplies electrical power and data on a standard CAT-5/CAT-6 Ethernet cable. Acting as a PoE PSE (Power Sourcing Equipment), compliant with IEEE 802.3at, each PoE port delivers up to 25W to a Powered Device (PD). The system has a total 100W power budget. PoE ports can automatically detect and determine if the connected device requires power or not, so it is compatible with standard Ethernet devices as well.

Each port has one dedicated PCI Express link for maximum network performance. Please refer to the table below for LED connection statuses.

Active/Link LED (Right)

LED Color	Status	Description
Orange	Off	Ethernet port is disconnected
	On	Ethernet port is connected and no data transmission
	Flashing	Ethernet port is connected and data is transmitting/receiving

Speed LED (Left)

LED Color	Status	Description
Green or Orange	Off	10 Mbps
	Green	100 Mbps
	Orange	1000/ 2500 Mbps

To utilize the Ethernet ports in Windows, you need to install corresponding driver for Intel® I226-IT controllers.

2.2.7 Power Button

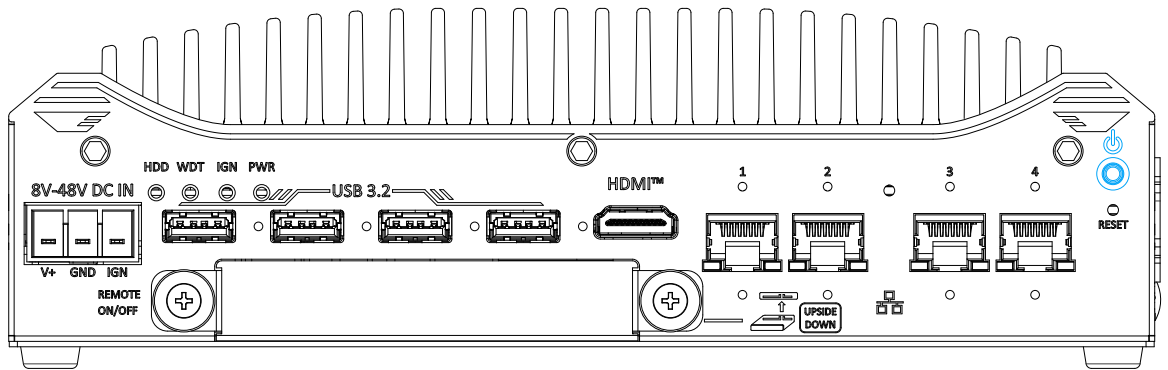

The power button is a non-latched switch for ATX mode on/off operation. To turn on the system, press the power button and the PWR LED should light-up green. To turn off the system, issuing a shutdown command in OS is preferred, or you can simply press the power button. To force shutdown when the system freezes, press and hold the power button for 5 seconds. Please note that there is a 5-second interval between on/off operations (i.e. once the system is turned off, there is a 5-second wait before you can power-on the system).

2.2.8 Reset Button

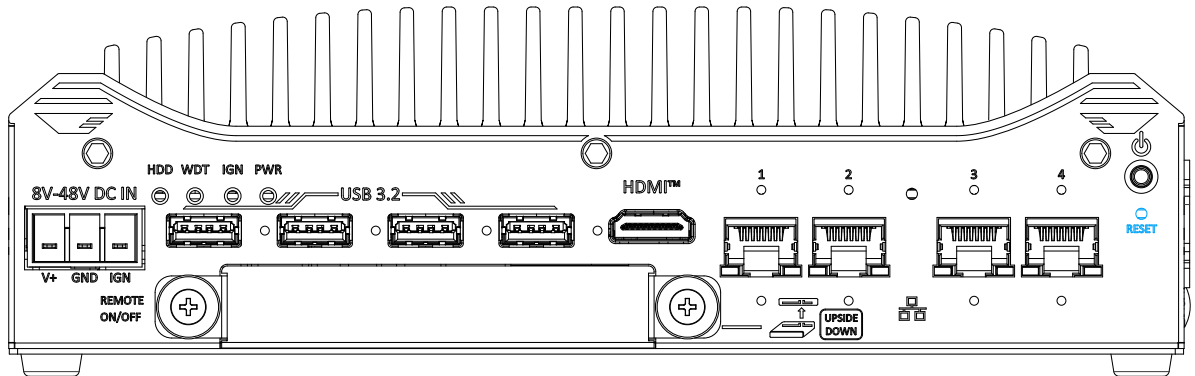

The reset button is used to manually reset the system in case of system halt or malfunction. To avoid unexpected reset, the button is purposely placed behind the panel. To reset, please use a pin-like object (eg. tip of a pen) to access the reset button.

2.2.9 2.5” Easy Swap Tray

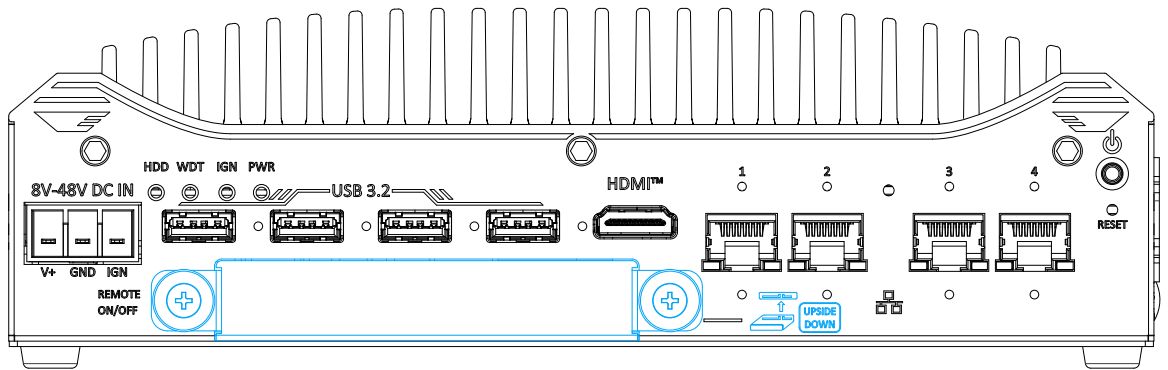

Designed for easy access, the system features an external hot-swappable 2.5” hot-swappable tray that supports a 7mm 2.5” HDD/ SSD. When installing an internal 2.5” SSD with the tray, please ensure the SSD is positioned upside down and secured to the tray using the 4x M3 P-type screw provided in the screw pack.

Please position the disk drive upside-down to match the SATA connectors when installing a 2.5” SSD/ HDD.

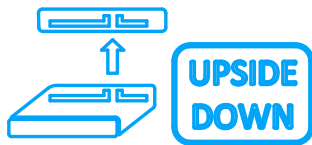

2.3 Rear Panel I/O

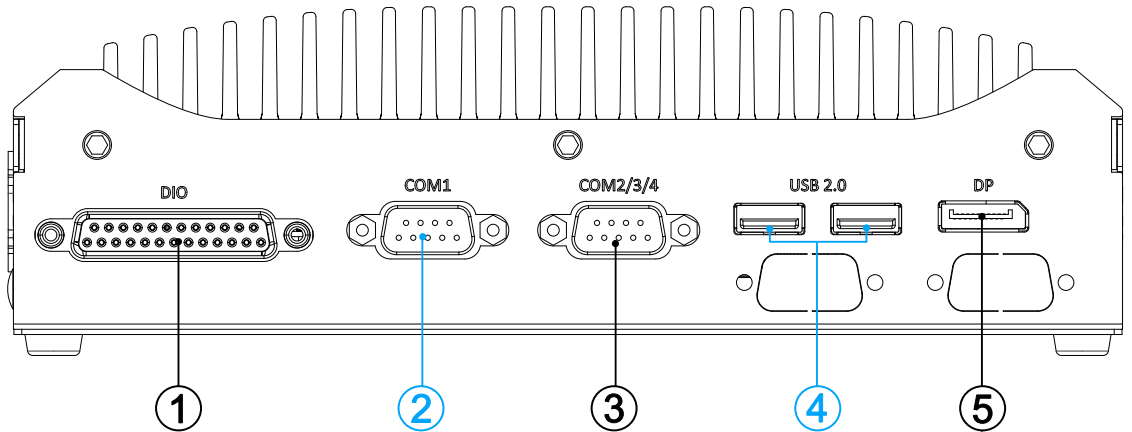

No.	Item	Description
1	Digital input/output	Via a DB25 connector, the system provides digital input/ output channels Nuvo-11531: 4x DI and 4x DO Nuvo-11588: 8x DI and 8x DO
2	COM1 Port	Software programmable RS-232/ 422/ 485 port.
3	COM2/3/4 Port	Can be configured as: COM2: single RS-422/ 485 port COM2/ COM3/ COM4: three 3-wire RS-232 ports
4	USB2.0 Ports	The USB 2.0 ports are backward with USB 1.1 / 1.0.
5	DisplayPort	Support display resolutions up to 3840 x 2160 @ 60Hz. Compatible with HDMI/ DVI via respective adapter/ cable (resolution may vary).

2.3.1 Digital Input/ Output

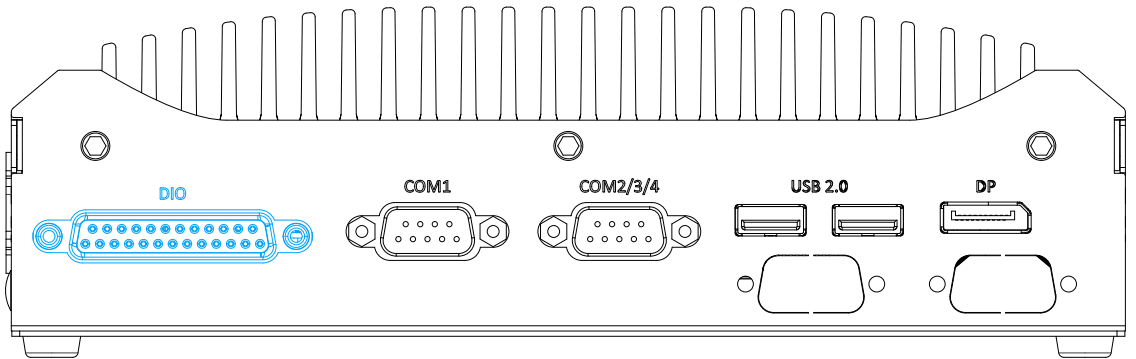

The system provides 4x digital input/ output channels (Nuvo-11531), or 8x digital input/ output channels (Nuvo-11588). The DIO functions support polling mode I/O access and DI change-of-state interrupt. Please refer to digital I/O pin definition and [Watchdog Timer & Isolated DIO](#) for information on wiring and programming the isolated DIO channels.

Digital I/O Pin Definition

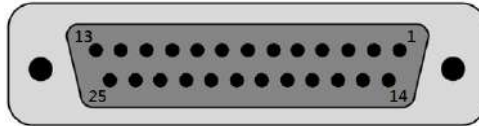

Pin No.	8xDI + 8xDO	4xDI + 4xDO
1	VDD	VDD
2	ISO_DO0_CN	-
3	ISO_DO2_CN	-
4	ISO_DO4_CN	ISO_DO0_CN
5	ISO_DO5_CN	ISO_DO1_CN
6	ISO_DO6_CN	ISO_DO2_CN
7	ISO_DO7_CN	ISO_DO3_CN
8	IGND	IGND
9	ISO_DI4_CN	-
10	ISO_DI5_CN	-
11	IGND	IGND
12	ISO_DI6_CN	-
13	ISO_DI7_CN	-
14	EOGND (GND for DO0, DO1, DO2, DO3)	-
15	ISO_DO1_CN	-
16	ISO_DO3_CN	-
17	ISO_DO4_RTN_CN	ISO_DO0_RTN_CN
18	ISO_DO5_RTN_CN	ISO_DO1_RTN_CN
19	ISO_DO6_RTN_CN	ISO_DO2_RTN_CN
20	ISO_DO7_RTN_CN	ISO_DO3_RTN_CN

21	ISO_DI0_CN	ISO_DI0_CN
22	ISO_DI1_CN	ISO_DI1_CN
23	IGND	IGND
24	ISO_DI2_CN	ISO_DI2_CN
25	ISO_DI3_CN	ISO_DI3_CN

Digital Input Wiring

Channel	Nuvo-11531: 4 channels Nuvo-11588: 8 channels
Type	Sink mode
Interface	Unipolar Photocoupler
Isolation Voltage	2500Vrms
Rated Input Voltage	0V-24V
Logic High Voltage	5V-24V
Logic Low Voltage	0V-1.5V
Operation Mode	Polling
Response Time (Rise)	3 μ s
Response Time (Fall)	3 μ s

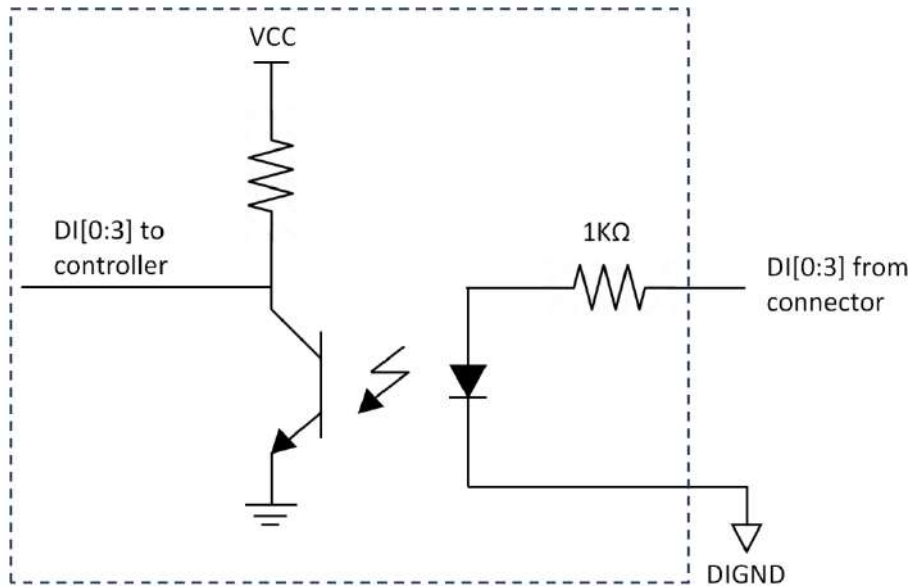

Digital Output Wiring

Channel	Nuvo-11531: 4 channels Nuvo-11588: 8 channels
Type	Sink mode
Interface	Bidirectional PhotoMOS
Isolation Voltage	1500V AC
Operation Voltage	0V-24V
Driving Current	250mA
Operation Mode	Polling
Response Time (Turn on)	660us ~ 2ms
Response Time (Turn off)	90us ~ 210ms

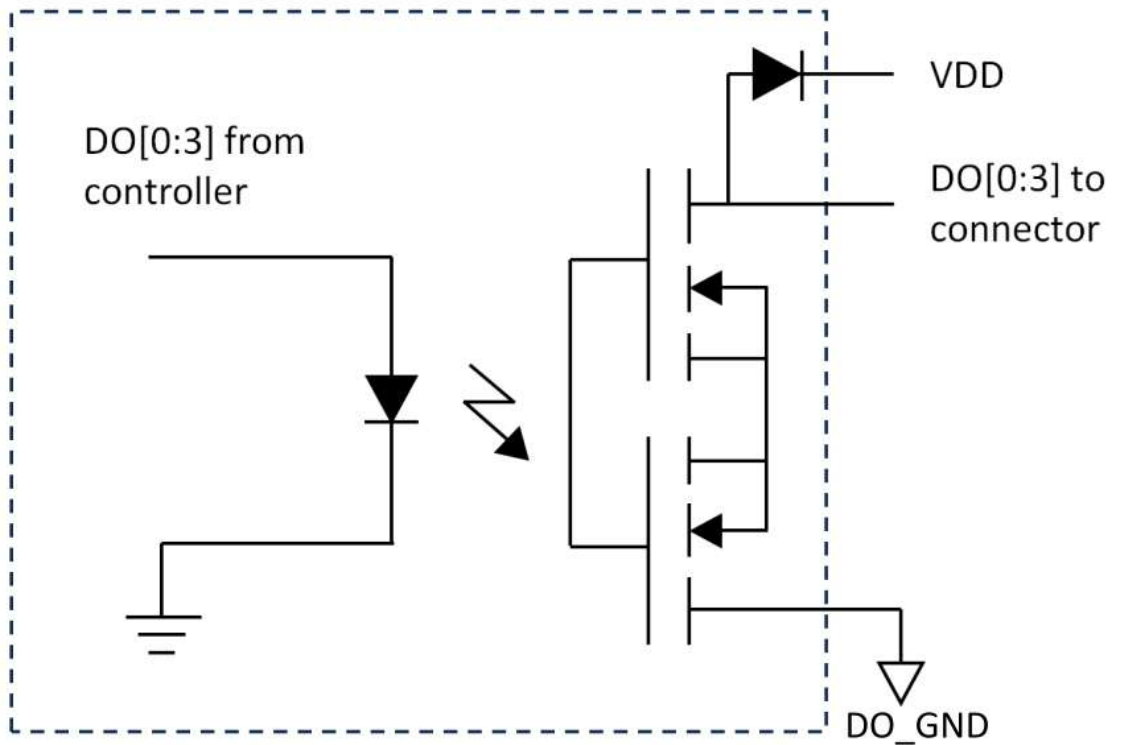

2.3.2 COM 1 Port

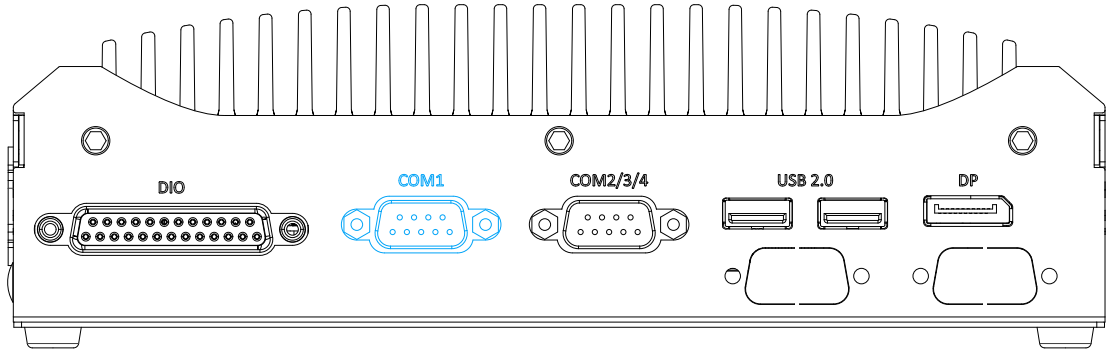

The system's COM1 port COM1 is software-configurable RS-232/ 422/ 485 port providing up to 115200 bps baud rate for communicating with external devices.

The operation modes of the port can be set in BIOS setup utility. The following table describes the pin definition of COM1 port.

COM Port Pin Definition

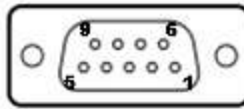

Pin#	COM1		
	RS-232 Mode	RS-422 Mode	RS-485 Mode (Two-wire 485)
1	DCD		
2	RX	422 TXD+	
3	TX	422 RXD+	485 TXD+/RXD+
4	DTR	422 RXD-	
5	GND	GND	
6	DSR		GND
7	RTS		
8	CTS	422 TXD-	485 TXD-/RXD-
9	RI		

2.3.3 COM2/3/4 Port

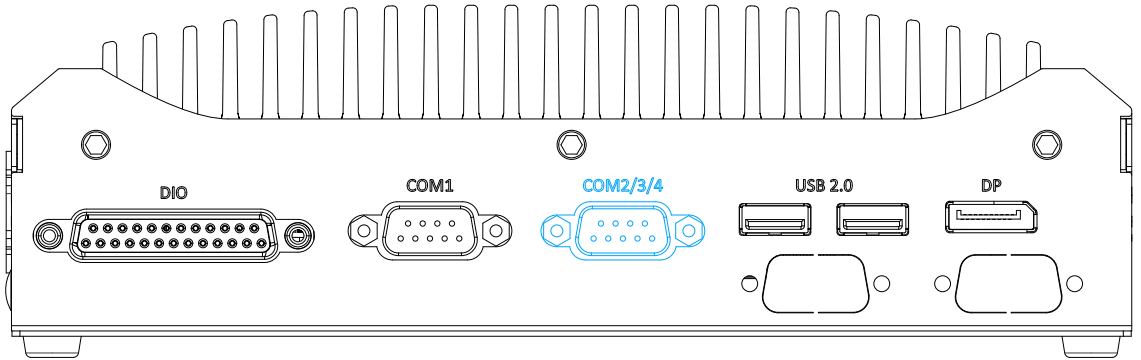

The port provides up to 921600 bps baud rate, the D-Sub male connector (COM2/ 3/ 4) can be configured in the BIOS as single RS-422/ 485 port (COM2) or three 3-wire RS-232 ports (COM2/COM3/COM4). Please refer to [COM2/ 3/ 4 Port Configuration](#) for configuring operation mode. An optional 1-to-3 Y-cable is available to connect three RS-232 devices.

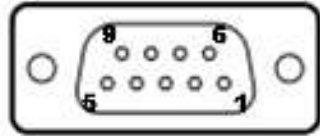

COM2/ 3/ 4 Pin



1-to-3 Y-cable

The following table describes the pin definition of the COM port

	3-port RS-232 COM2/ 3/ 4		
Pin#	COM2	COM3	COM4
1			
2	RX		
3	TX		
4		TX	
5	GND	GND	GND
6		RX	
7			TX
8			RX
9			

	Single port RS-422/ 485 COM2	
Pin#	RS-422	RS-485
1		
2	TxD+	TxD+/ RxD+
3	RxD+	
4	RxD-	
5	GND	GND
6		
7		
8	TxD-	TxD-/ RxD-
9		

2.3.4 USB 2.0 Port

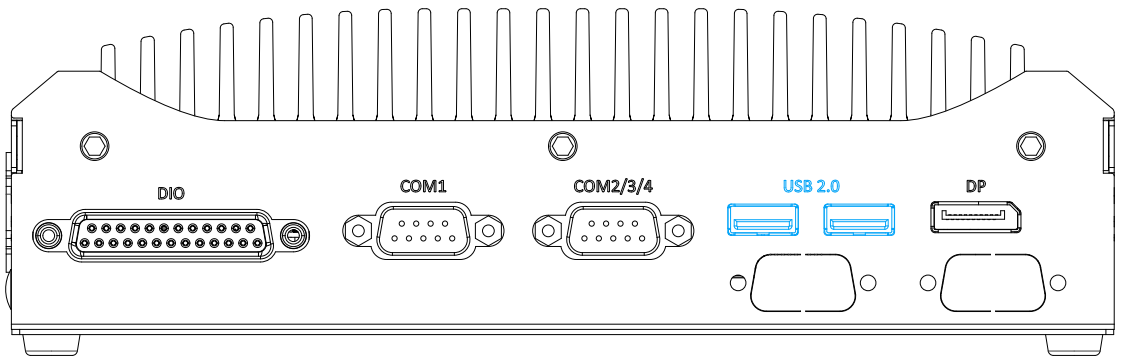

The USB2.0 ports are implemented via native xHCI (eXtensible Host Controller Interface) and are backward compatible with USB 1.1 and USB 1.0 devices. UEFI USB support is also provided so you can use USB keyboard/ mouse in UEFI shell environment.

xHCI driver is supported natively in Windows 10/ 11, therefore you do not need to install xHCI driver to utilize USB functions.

2.3.5 DisplayPort

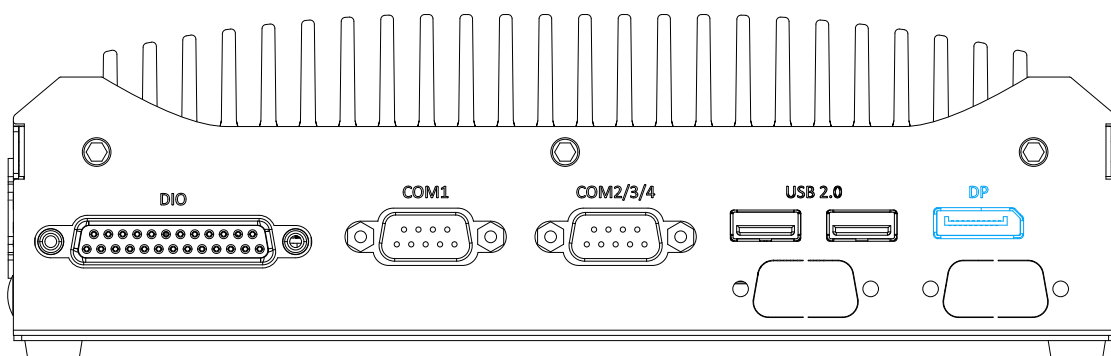

The system has a DisplayPort (DP) output which is a digital display interface that mainly connect video source and carry audio to a display device. When connecting a DP, it can deliver up to 4K UHD (3840 x 2160 @ 60Hz) in resolution. The system is designed to support active DP adapter/ cable. You can connect to other display devices using active DP-to-HDMI cable or DP-to-DVI cable.

The system supports two independent display outputs by connecting display devices to HDMI and DisplayPort connection. To support multiple display outputs and achieve best DisplayPort output resolution in Windows, you need to install corresponding graphics drivers. Please refer to section [OS Support and Driver Installation](#) for details.

2.4 SlimSAS 8i SFF-8654 Port (Nuvo-11588 Only)

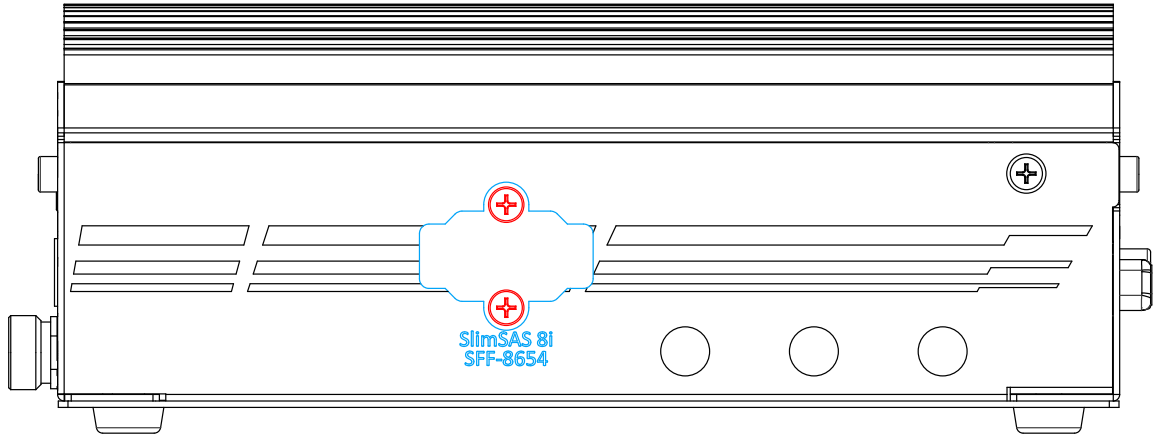

The SlimSAS 8i port features a latch mechanism to ensure a secure connection, making it ideal for industrial-grade applications where reliability and serviceability are critical.

To access the SlimSAS 8i port, remove the two screws (in **red**), then remove the SlimSAS cover (in **blue**).

Pin Definition

Host	SFF-8654	Host	SFF-8654
A1	GND	B1	GND
A2	RXP0	B2	TXP0
A3	RXN0	B3	TXN0
A4	GND	B4	GND
A5	RXP1	B5	TXP1
A6	RXN1	B6	TXN1
A7	GND	B7	GND
A8	SUSPWR_SEQUENCE_Control	B8	SMBUS_CLK_A
A9	NC	B9	SMBUS_DATA_A
A10	GND	B10	GND
A11	REFCLK_P_A	B11	PCle_PLTRST_A
A12	REFCLK_N_A	B12	RUNTIMEPWR_SEQUENCE_Control
A13	GND	B13	GND
A14	RXP2	B14	TXP2
A15	RXN2	B15	TXN2
A16	GND	B16	GND
A17	RXP3	B17	TXP3
A18	RXN3	B18	TXN3
A19	GND	B19	GND

A20	RXP4	B20	TXP4
A21	RXN4	B21	TXN4
A22	GND	B22	GND
A23	RXP5	B23	TXP5
A24	RXN5	B24	TXN5
A25	GND	B25	GND
A26	SUSPWR_SEQUENCE_Control	B26	SMBUS_CLK_B
A27	NC	B27	SMBUS_DATA_B
A28	GND	B28	GND
A29	REFCLK_P_B	B29	PCIe_PLTRST_B
A30	REFCLK_N_B	B30	RUNTIMEPWR_SEQUENCE_Control
A31	GND	B31	GND
A32	RXP6	B32	TXP6
A33	RXN6	B33	TXN6
A34	GND	B34	GND
A35	RXP7	B35	TXP7
A36	RXN7	B36	TXN7
A37	GND	B37	GND

2.5 Internal I/O Functions

In addition to I/O connectors on the front panel, the system also provides internal on-board connectors, such as M.2, mini PCIe with SIM slots, etc. In this section, we'll illustrate these internal I/O functions.

2.5.1 SODIMM DRAM Slot

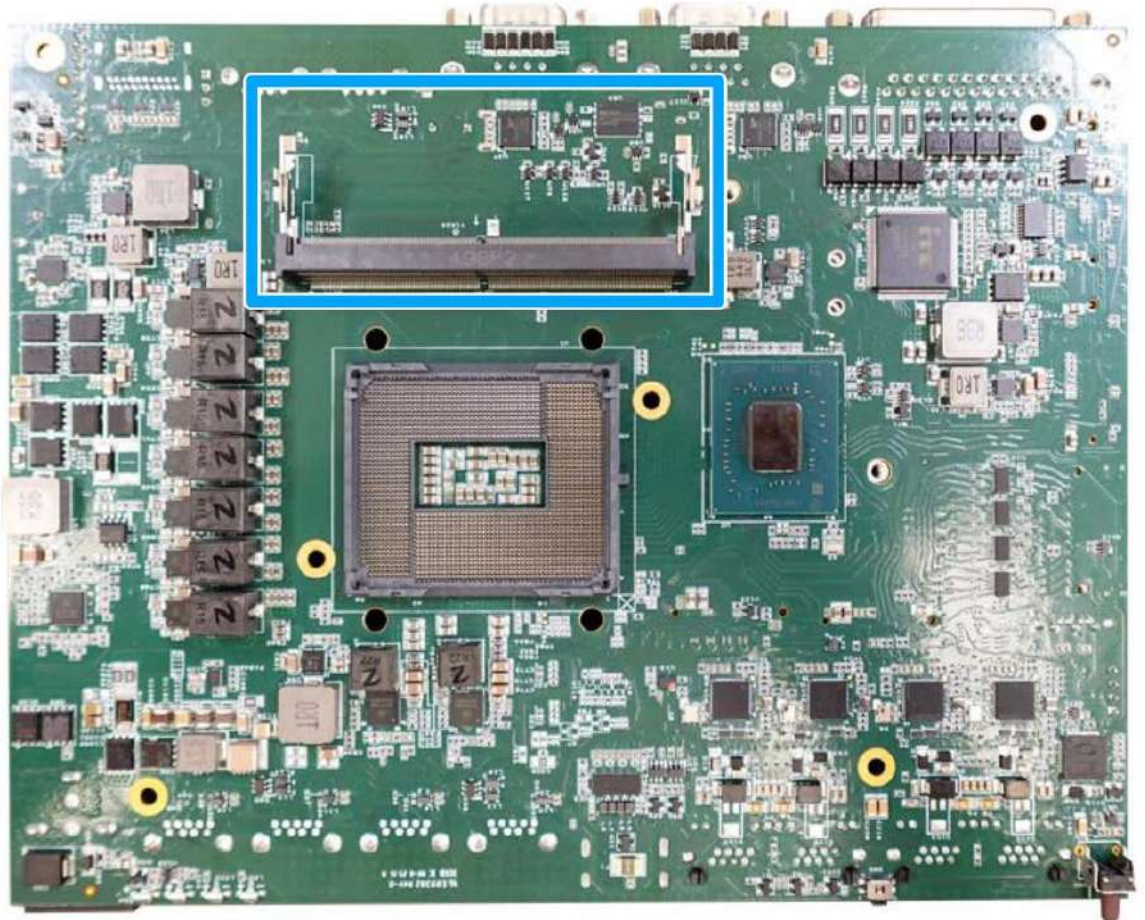

The system motherboard supports a DDR5 6400 SODIMMs memory module up to 64GB.



NOTE

When changes are made to DRAM module(s), such as remove and reinstall (into the memory slot), it will result in approximately a 30 to 60 seconds delay when booting up for the first time after such change(s).

2.5.2 mini-PCIe Socket & Pin Definition

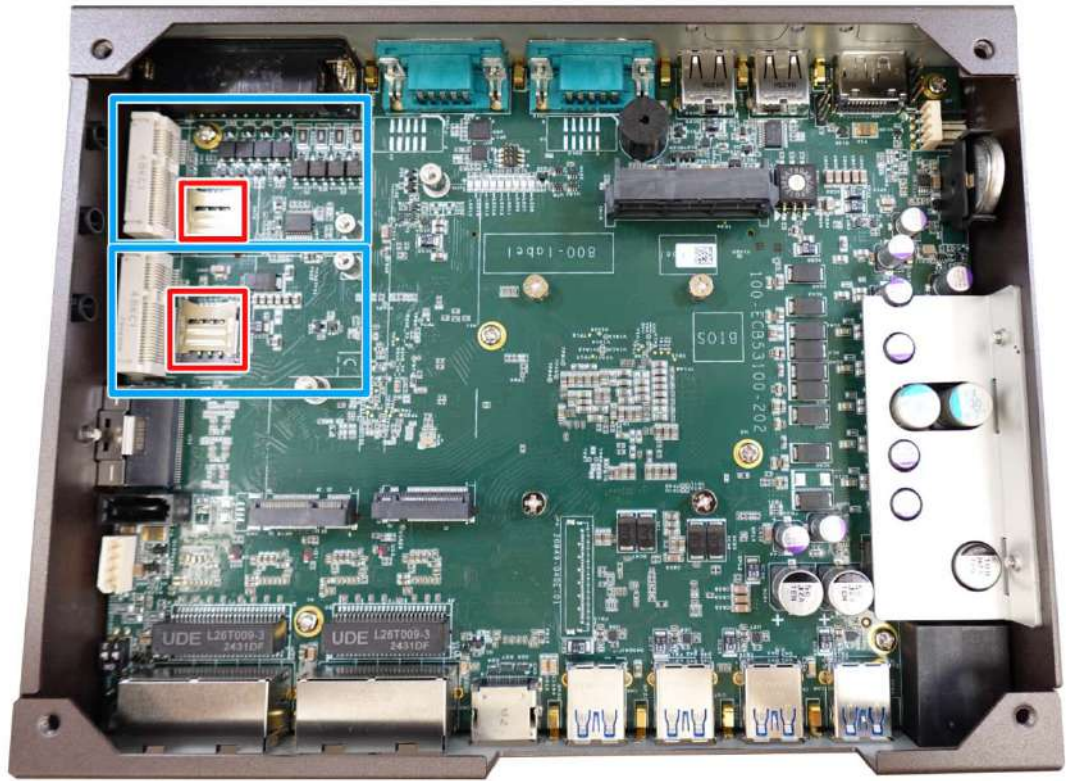

The system is equipped with two mPCIe slots (in **blue**), each coupled with a Micro-SIM socket (indicated in **red**) for installing 3G/4G modules. Please note that the mPCIe slots are located very close to the M.2 M-key slots, so using an additional mPCIe-to-M.2 adapter may interfere with the M.2 M-key NVMe module.

For wireless communication, multiple SMA antenna apertures can be located on the side.

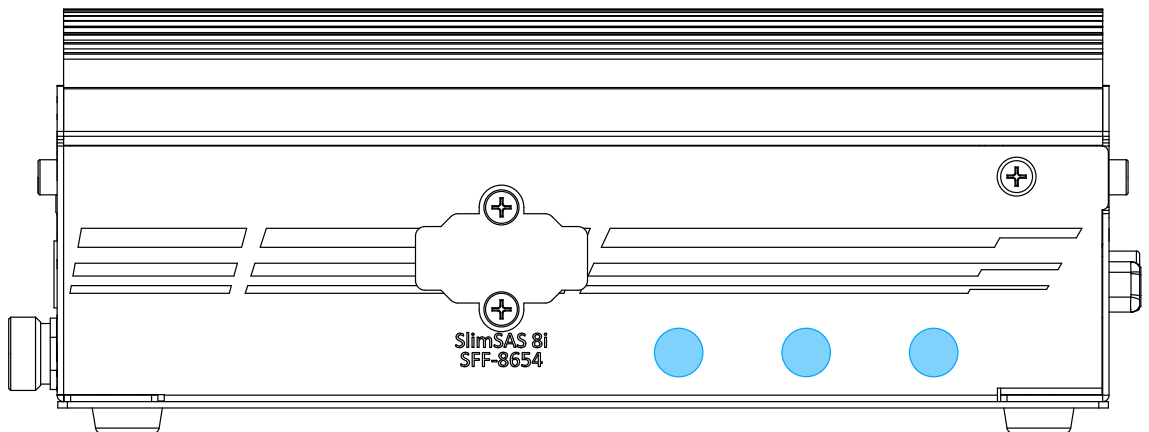

Side panel antenna opening

mini-PCle socket definition

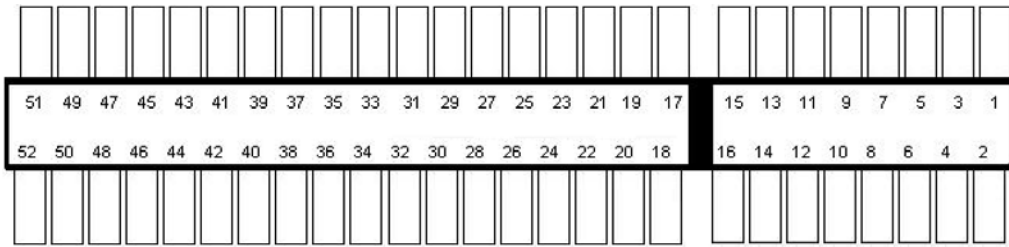

Pin #	Signal	Pin #	Signal
1	WAKE#	2	+3.3Vaux
3	COEX1	4	GND
5	COEX2	6	+1.5V
7	CLKREQ#	8	UIM PWR
9	GND	10	UIM DATA
11	REFCLK-	12	UIM CLK
13	REFCLK+	14	UIM RESET
15	GND	16	UIM VPP
Mechanical Key			
17	Reserved* (UIM C8)	18	GND
19	Reserved* (UIM C4)	20	W DISABLE#
21	GND	22	PERST#
23	PERn0	24	+3.3Vaux
25	PERp0	26	GND
27	GND	28	+1.5V
29	GND	30	SMB CLK
31	PETn0	32	SMB DATA
33	PETp0	34	GND
35	GND	36	USB D-
37	GND	38	USB D+
39	+3.3Vaux	40	GND
41	+3.3Vaux	42	Reserved
43	GND	44	Reserved
45	Reserved	46	Reserved
47	Reserved	48	+1.5V
49	Reserved	50	GND
51	Reserved	52	+3.3Vaux



WARNING

Some off-the-shelf mini-PCle 5G/4G modules are not compliant to standard mini-PCle interface. They use 1.8V I/O signals instead of standard 3.3V I/O and may cause signal conflict. Please consult with Neosys for compatibility when in doubt! Installing an incompatible 4G module may damage the system or the module itself may be damaged.

2.5.3 M.2 2230 (E Key) Slot & Pin Definition

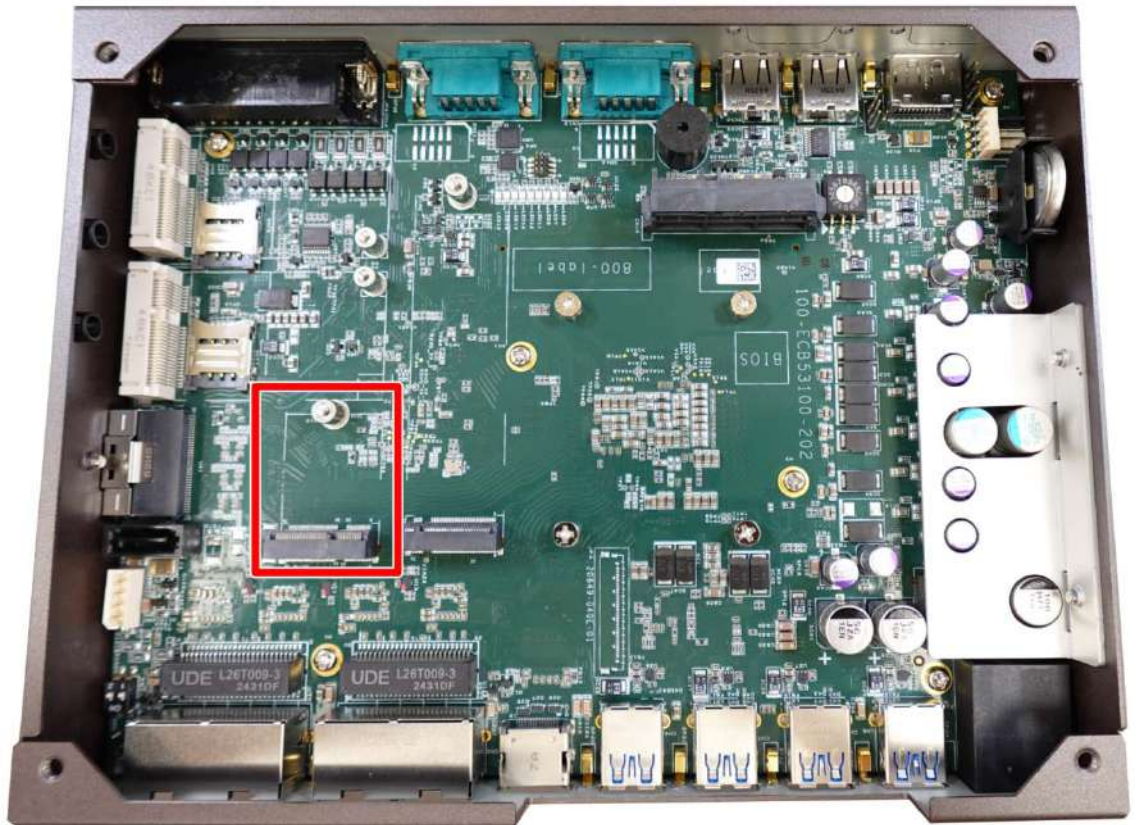

The system has an M.2 2230 E-key slot for WiFi module installation.

For wireless communication, multiple SMA antenna apertures can be located on the side.

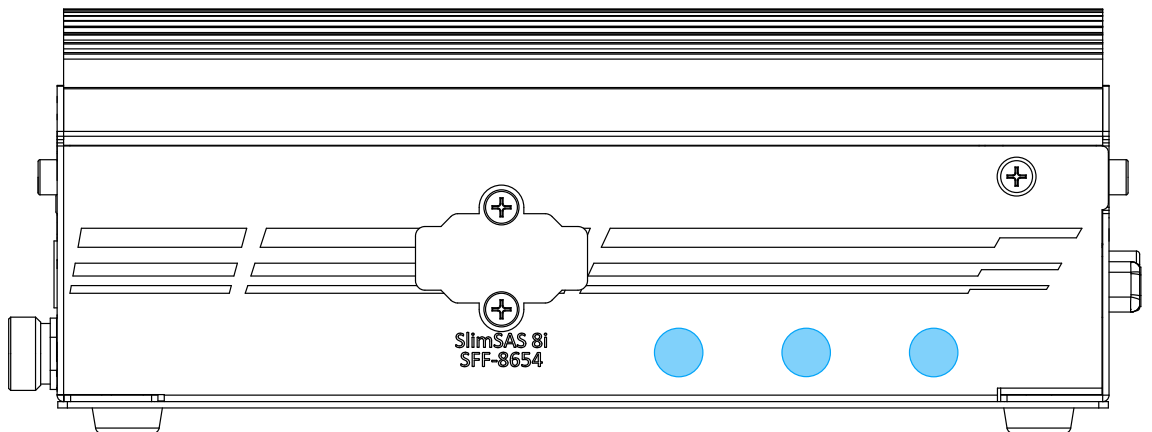

Side panel antenna opening

M.2 (E Key) Slot Pin Definition

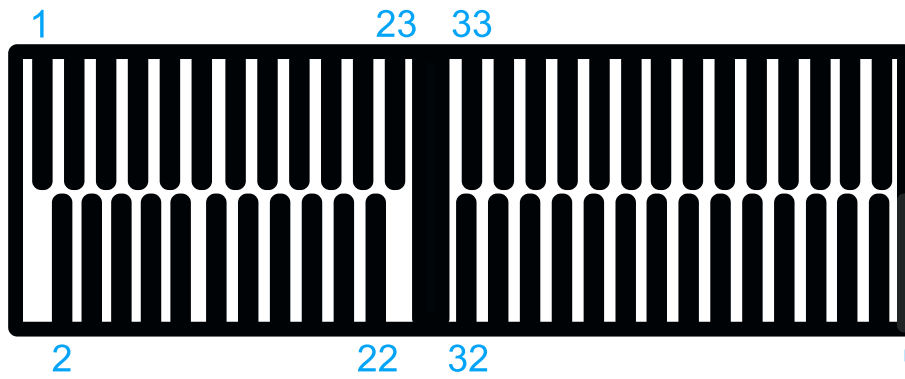

Pin #	Signal	Pin #	Signal
1	GND	2	+3V3
3	USB_D+	4	+3V3
5	USB_D-	6	
7	GND	8	
9		10	-
11		12	
13		14	
15		16	
17		18	GND
19		20	
21	-	22	-
23	-		
Mechanical Key			
33	GND	32	
35	PETP0	34	
37	PETN0	36	
39	GND	38	
41	PER P0	40	
43	PER N0	42	
45	GND	44	
47	REFCLK_P0	46	
49	REFCLK_N0	48	
51	GND	50	
53	CLKREQ#	52	PERST#
55		54	
57	GND	56	W_DISABLE#
59		58	
61		60	
63	GND	62	
65		64	
67		66	
69	GND	68	
71		70	
73		72	+3V3
75	GND	74	+3V3

2.5.4 SATA Ports

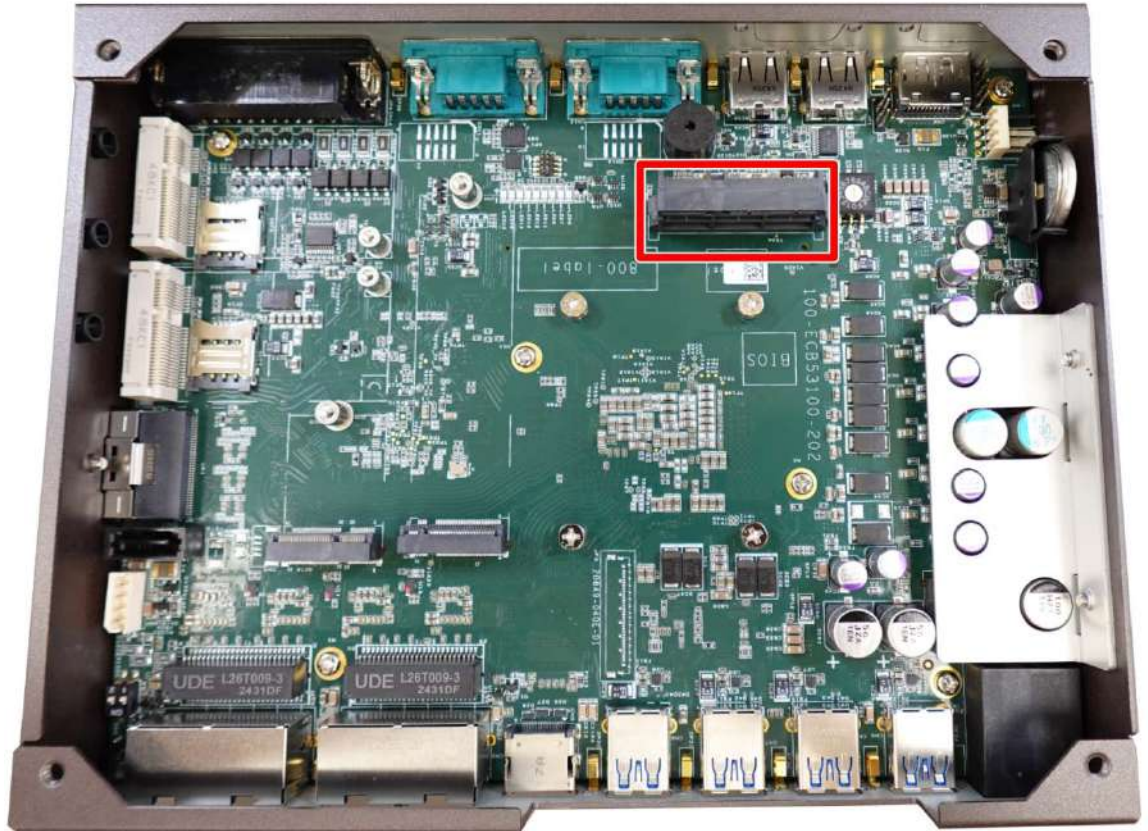

The system has a SATA port for the 2.5" easy swap tray. It supports Gen3, 6 Gb/s SATA signals.

You may refer to the SATA Configuration section for SATA settings.



NOTE

Supports up to a 7mm thickness 2.5" HDD/ SSD.

2.5.5 Ignition Control Switch (Optional)

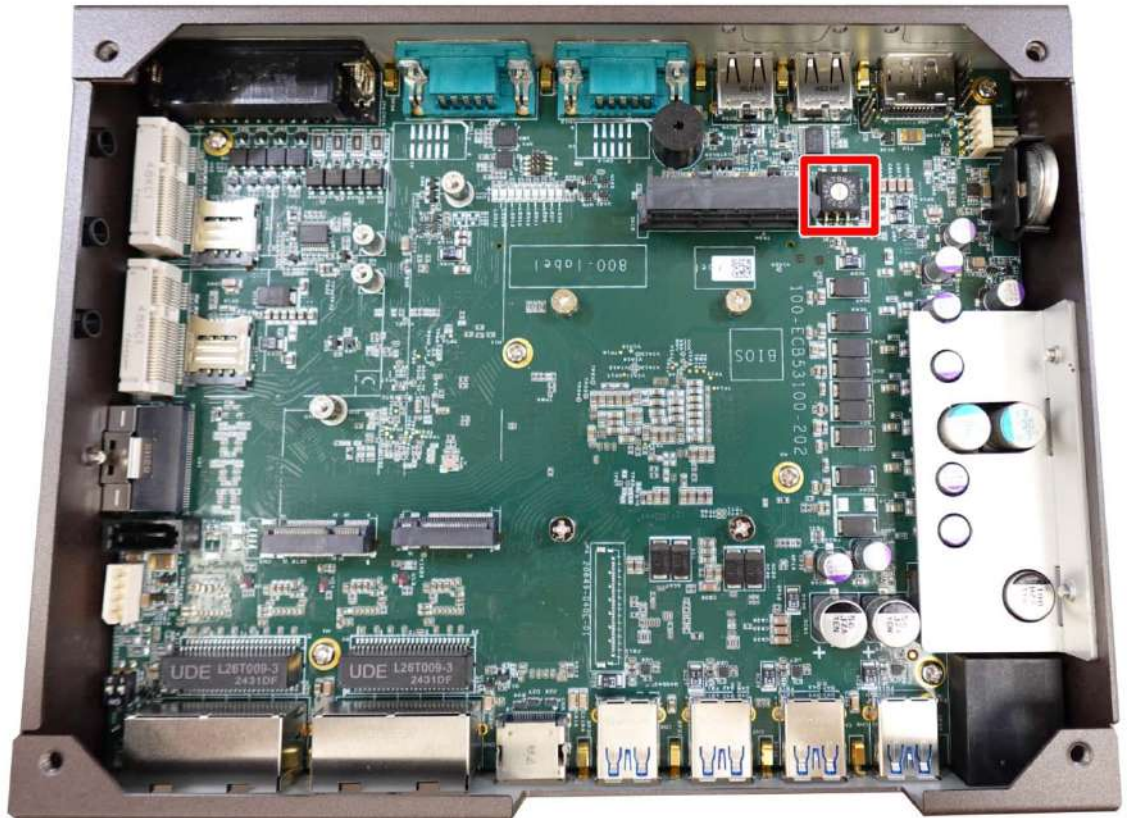

The ignition power control switch features multiple modes for pre and post ignition settings. Please refer to the section Ignition Power Control for details. Please use a flathead screwdriver to adjust the position of the ignition power control switch.

For details, please refer to the section [Ignition Power Control](#) for details

2.5.6 M.2 2280 (M Key) Slot for NVMe SSD

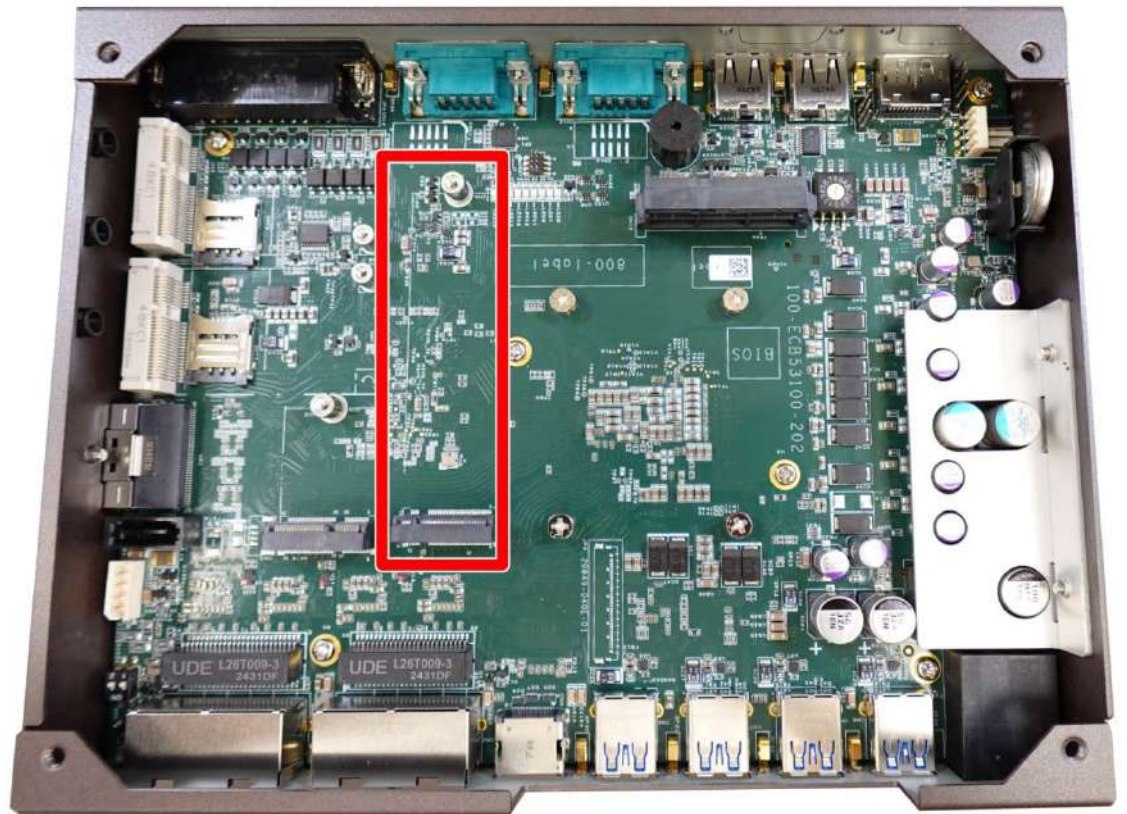

The system has a Gen4 x4 PCIe M.2 2280 slot for you to install an NVMe SSD. The M.2 NVMe SSD offers significantly better system performances when compared to a 2.5" SSD.

M.2 (M Key) Slot Pin Definition

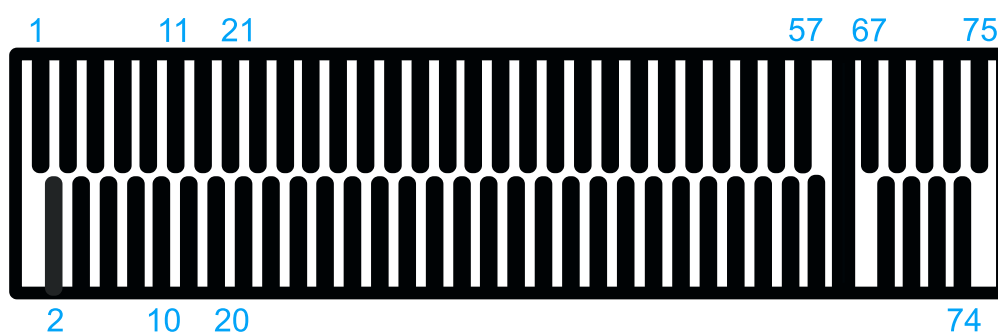

Pin #	Signal	Pin #	Signal
1	GND	2	+3V3
3	GND	4	+3V3
5	PERN3	6	-
7	PERP3	8	-
9	GND	10	DAS/DSS_N
11	PETN3	12	+3V3
13	PETP3	14	+3V3
15	GND	16	+3V3
17	PERN2	18	+3V3
19	PERP2	20	-
21	GND	22	-
23	PETN2	24	-
25	PETP2	26	-
27	GND	28	-
29	PERN1	30	-
31	PERP1	32	-
33	GND	34	-
35	PETN1	36	-
37	PETP1	38	-
39	GND	40	-
41	PERn0	42	-
43	PERp0	44	-
45	GND	46	-
47	PETn0	48	-
49	PETp0	50	PERST_N
51	GND	52	-
53	REFCLKN	54	-
55	REFCLKP	56	-
57	GND	58	-
Mechanical Key			
67	-	68	SUSCLK
69	PEDET	70	+3V3
71	GND	72	+3V3
73	GND	74	+3V3
75	GND		

2.5.7 DIP Switch SlimSAS 8i Port

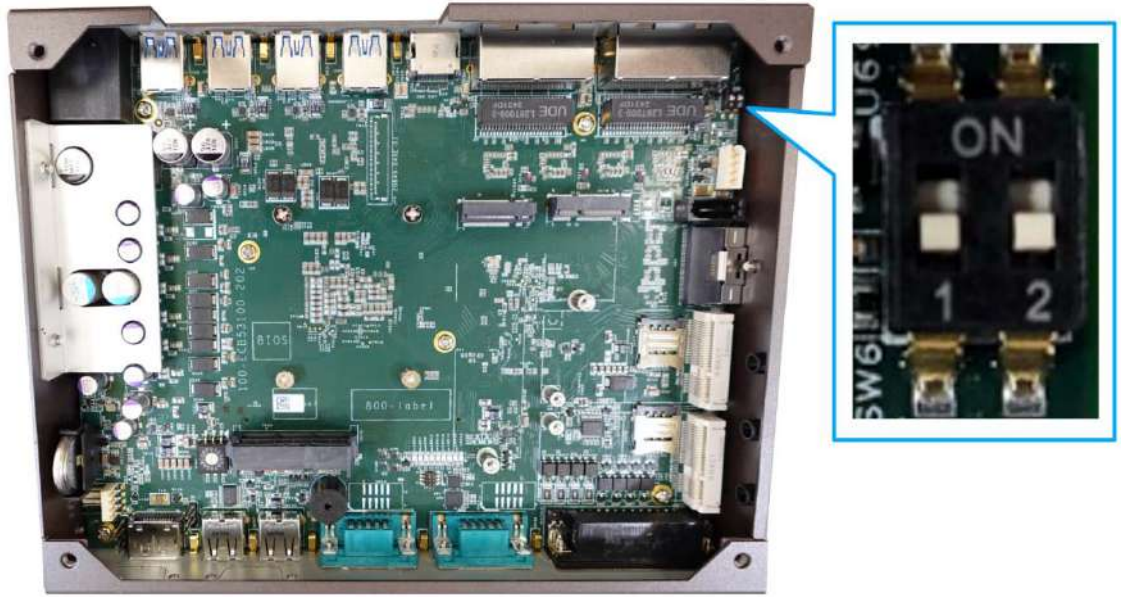

The DIP switch (indicated in **blue**) is reserved for manufacturing/ engineering purposes and should already be configured out of the factory. The table below shows the system default DIP switch settings for reference purposes.

	DIP switch #1	DIP switch #2
On	Nuvo-11588 SlimSAS: One PCIe x8	Enable BIOS upgrade
Off	Nuvo-11588 SlimSAS: Dual PCIe x4	Disable BIOS upgrade

3 System Installation

Before disassembling the system enclosure and installing components and modules, please make sure you have done the following:

- It is recommended that only qualified service personnel should install and service this product to avoid injury or damage to the system.
- Please observe all ESD procedures at all times to avoid damaging the equipment.
- Before disassembling your system, please make sure the system has powered off, all cables and antenna (power, video, data, etc.) are disconnected.
- Place the system on a flat and sturdy surface (remove from mounts or out of server cabinets) before proceeding with the installation/ replacement procedure.

3.1 Disassembling the System

To access M.2 and mini-PCIe slots, the 2.5" tray and bottom panel need to be removed.

1. Turn the thumb screws anti-clockwise on the 2.5" easy swap tray until it's loose.

2. Remove the 2.5" easy swap tray out of the system.

3. Turn the system upside-down and remove the four screws (indicated in **blue**).



4. Gently wiggle and separate the bottom panel from the system.



5. From here, you can access the system's M.2 and mini-PCIe slots.

3.2 Installing Internal Components

3.2.1 CPU Installation for Barebone System

1. Please refer to the section "[Disassembling the system](#)".
2. To install the CPU, you will need to separate the heatsink and the motherboard. To do so, on the I/O panel with the 3-pin terminal block, remove the hexa-screws indicated below.

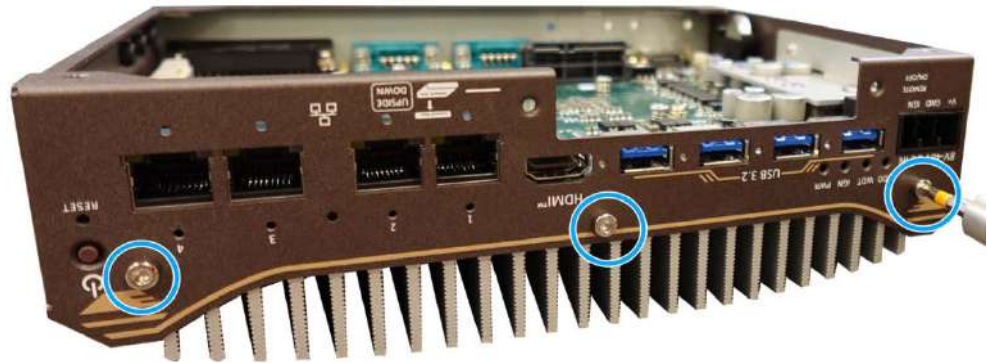

3. On the I/O panel with the DisplayPort, remove the hexa-screws indicated below.

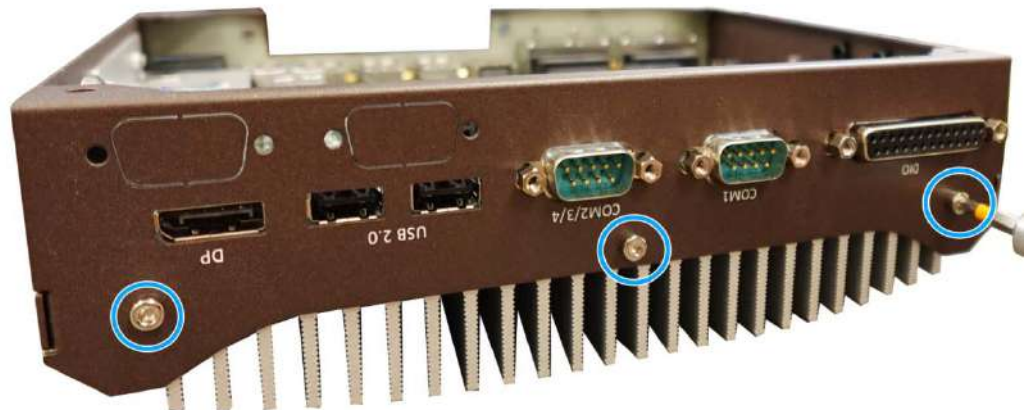

4. Remove the screw indicated on the side panel.

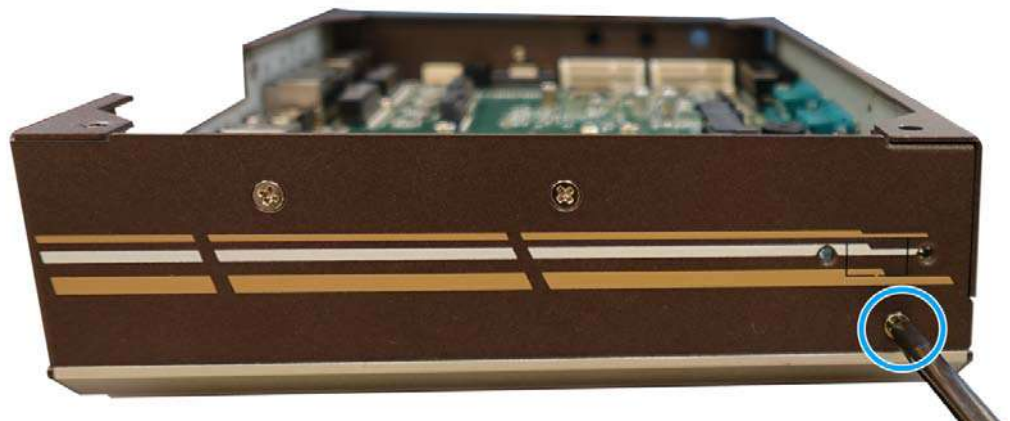

5. Separate the two I/O panels.
6. Remove the screws indicated on the motherboard.

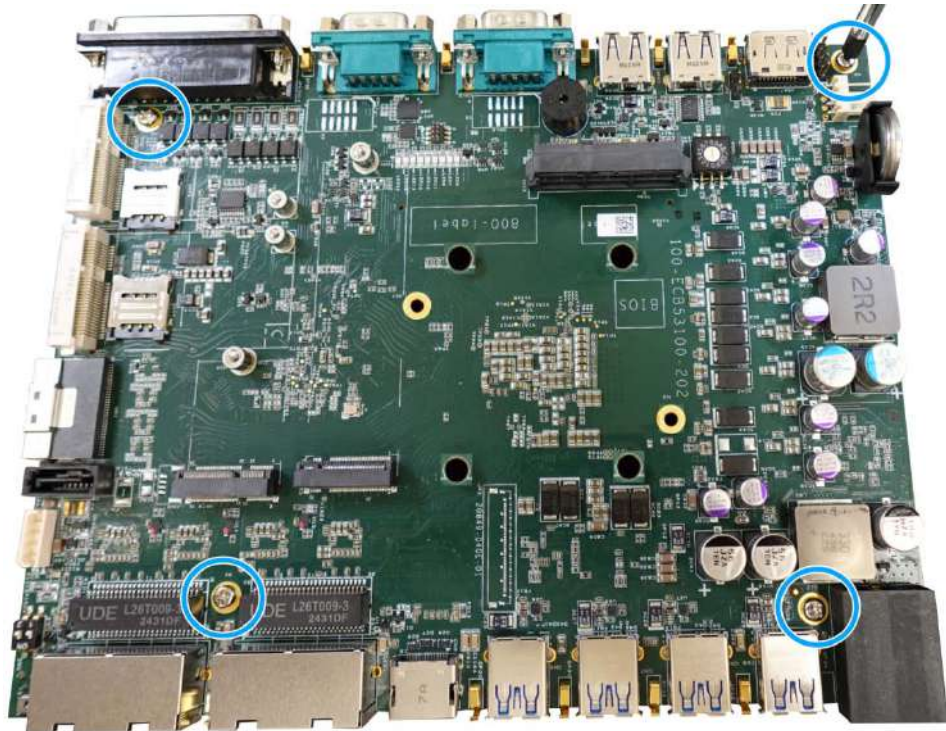

7. Gently lift and separate the motherboard and the heatsink to gain access to the CPU socket and DRAM slot.

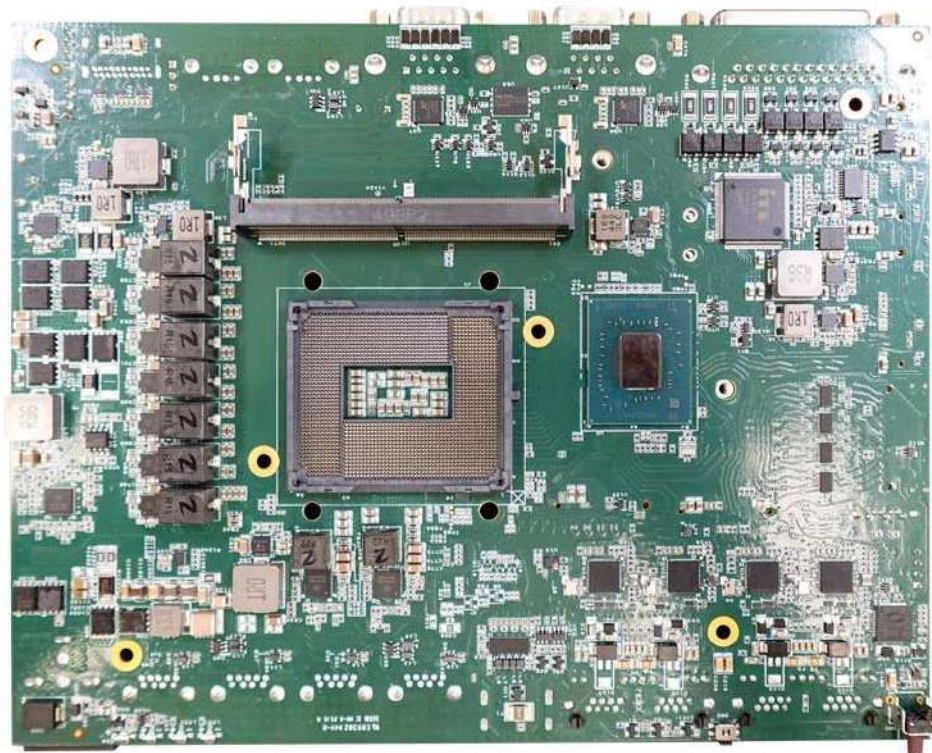

- Gently separate the motherboard from the heatsink, you'll see the CPU socket protective cover, place finger tips underneath the sign "REMOVE" for leverage and gently lift the cover.

 **WARNING**

With the protective cover removed, please be careful when handling the motherboard. DO NOT touch the pins in the LGA socket!

- Remove the CPU from its container/ tray. Lower the CPU into the socket matching the notches on the side (indicated by the **blue arrows**).



10. Locate the CPU retention bracket (holder) from the accessory box. Place the retention bracket on the CPU and hold it in place. Make sure the indicator triangle engraved on the CPU's integrated heat spreader (HIS) and the triangle indicator on the retention bracket are positioned in the same corner (indicated by **blue circles**).



11. Turn the motherboard around while holding the CPU retention bracket in-place, and secure the bracket by tightening two M3 P-head screws on the other side of the motherboard.

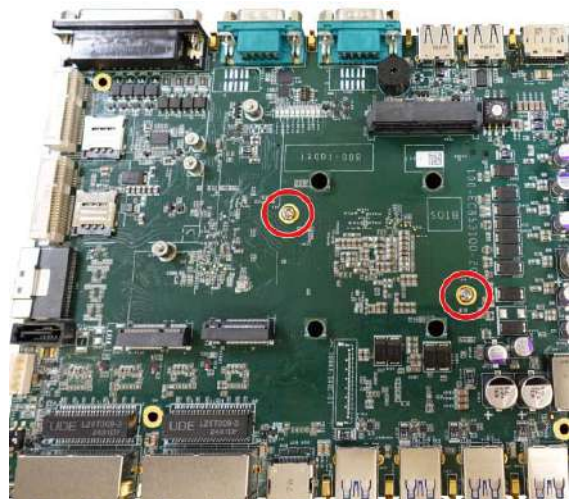

Hold CPU bracket firmly and turn the motherboard around

Secure two M3 P-head screws

12. Remove all thermal pads' protective films on the heatsink, if not already removed.

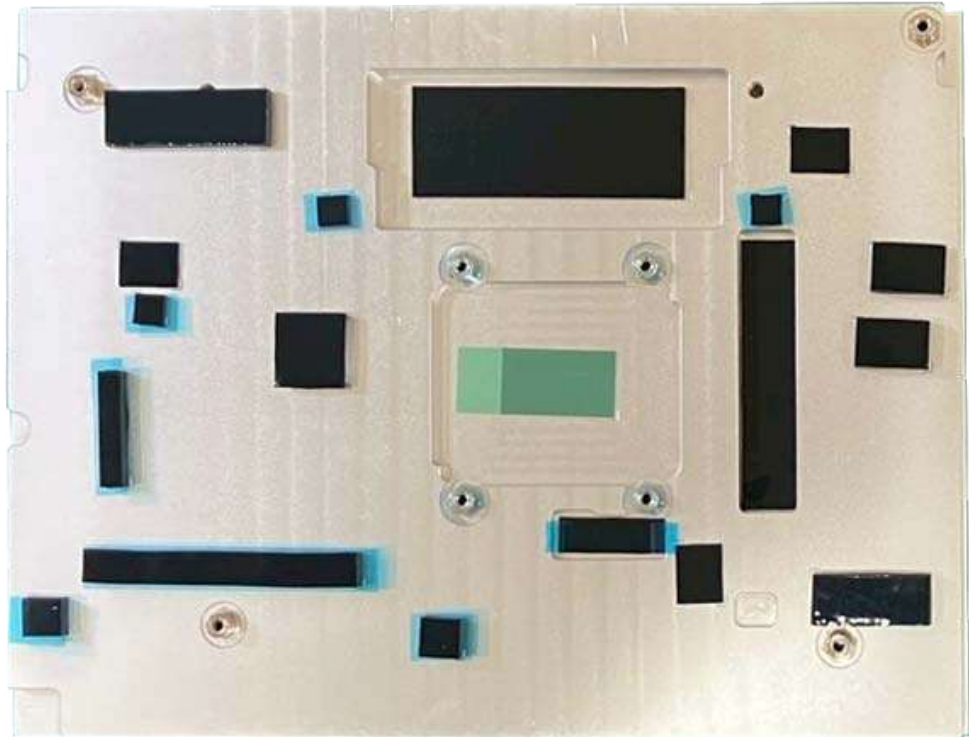

13. With the four motherboard standoffs aligned, gently lower the motherboard onto the heatsink and secure the four screws.

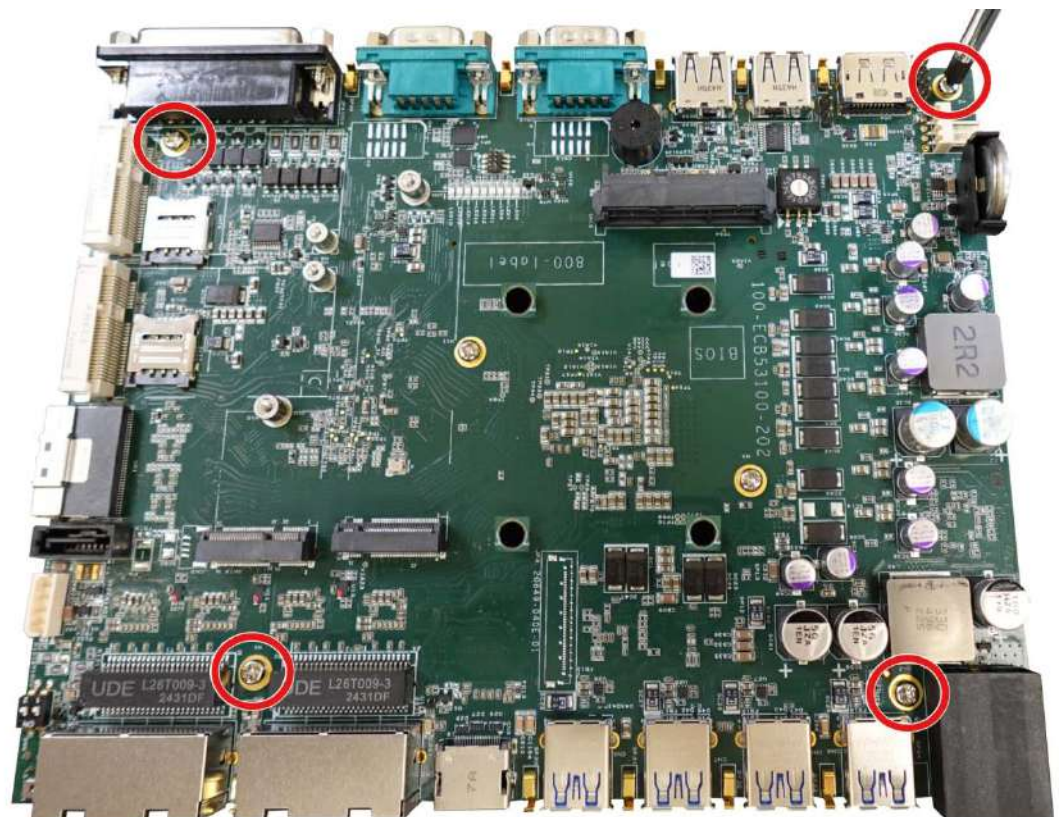

- Once the motherboard has been installed, you're ready to secure the four screws that help the heatsink apply pressure to the CPU/ chipset die. You'll want to apply even pressure to the corners by gradually tightening each screw. Please refer to the recommended order when tightening the screws.

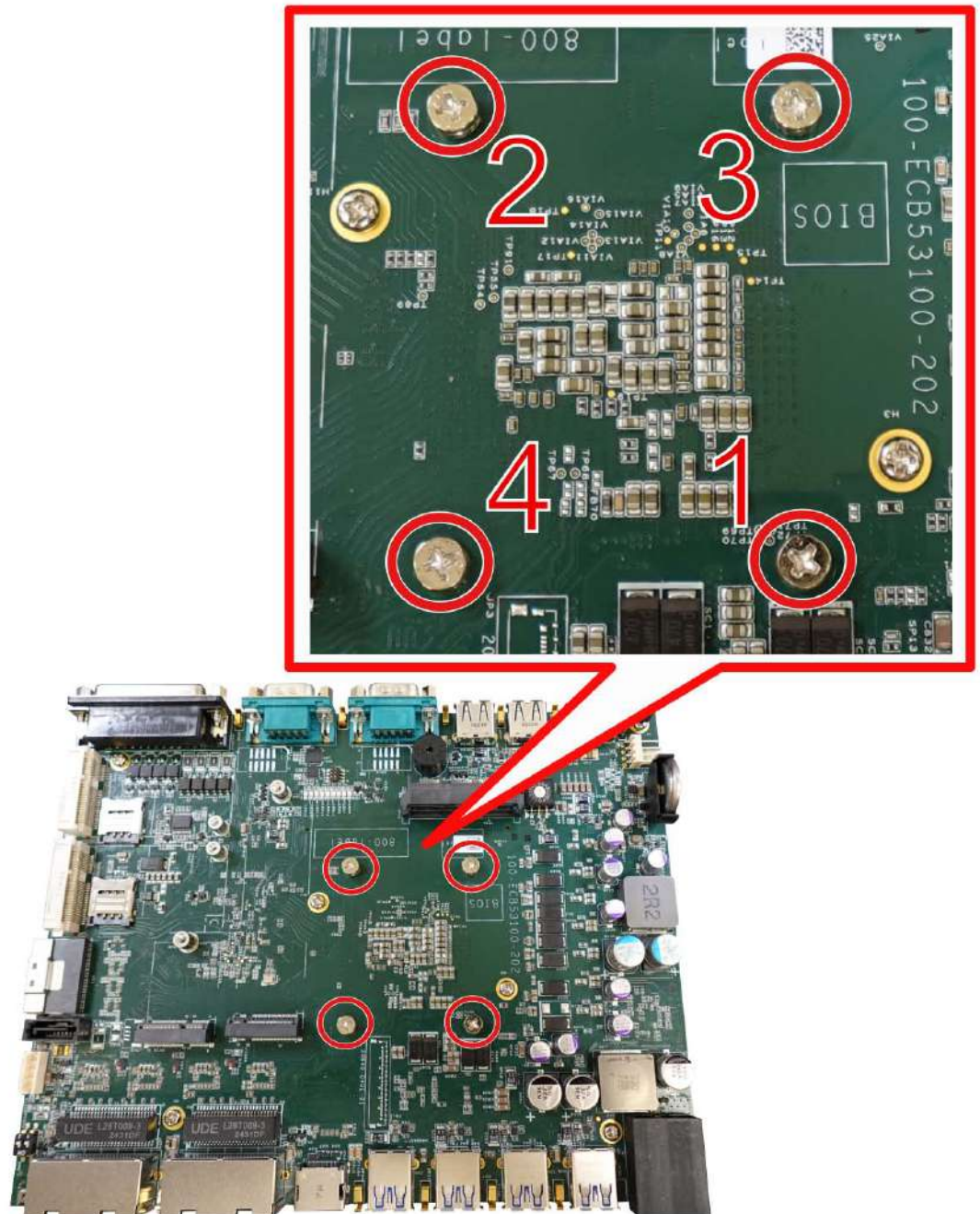

15. Reinstall the two I/O panels. Note the panel insertion on the side.



16. Secure the screw indicated.



17. Secure the hexa-screws on both I/O panels.



18. [Reinstall the system enclosure](#) when done.
19. If you need to install other components, please refer to respective sections.

3.2.2 Remove and Replace the Existing CPU

1. Please refer to the section "[Disassembling the system](#)".
2. To replace the existing CPU, you will need to separate the heatsink and the motherboard. To do so, on the I/O panel with the 3-pin terminal block, remove the hexa-screws indicated below.

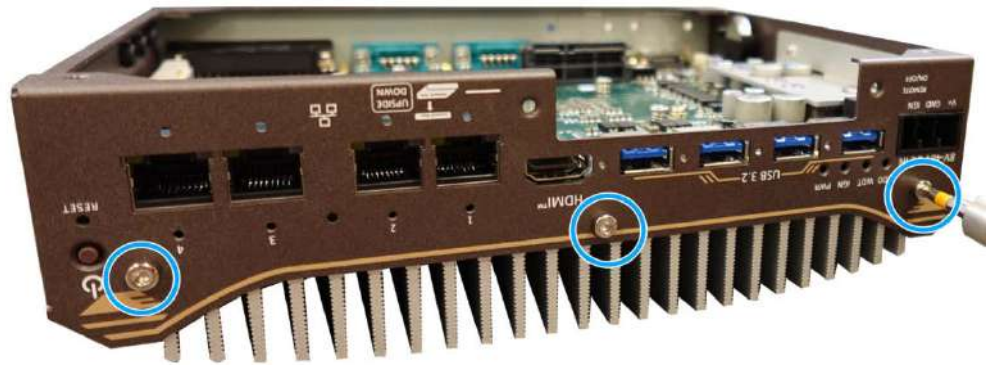

3. On the I/O panel with the DisplayPort, remove the hexa-screws indicated below.



4. Remove the screw indicated on the side panel.



5. Separate the two I/O panels.

6. Remove the eight screws indicated below.

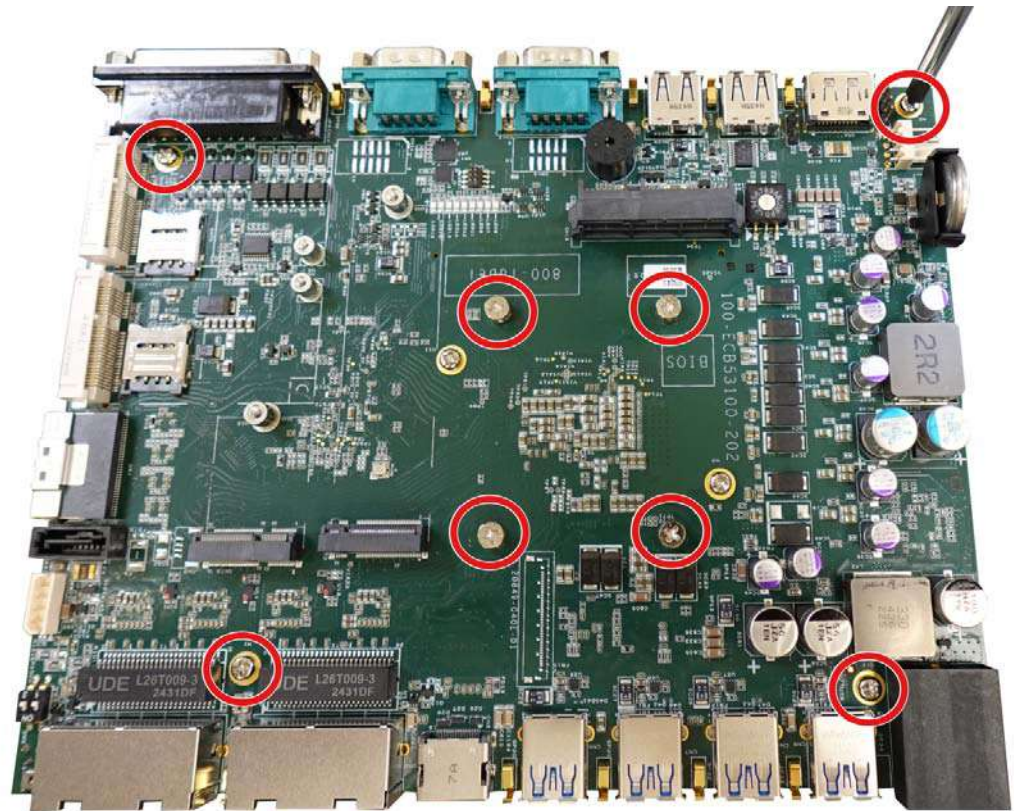

7. Remove the screws indicated once you separate the heatsink from the motherboard to remove the CPU holder.

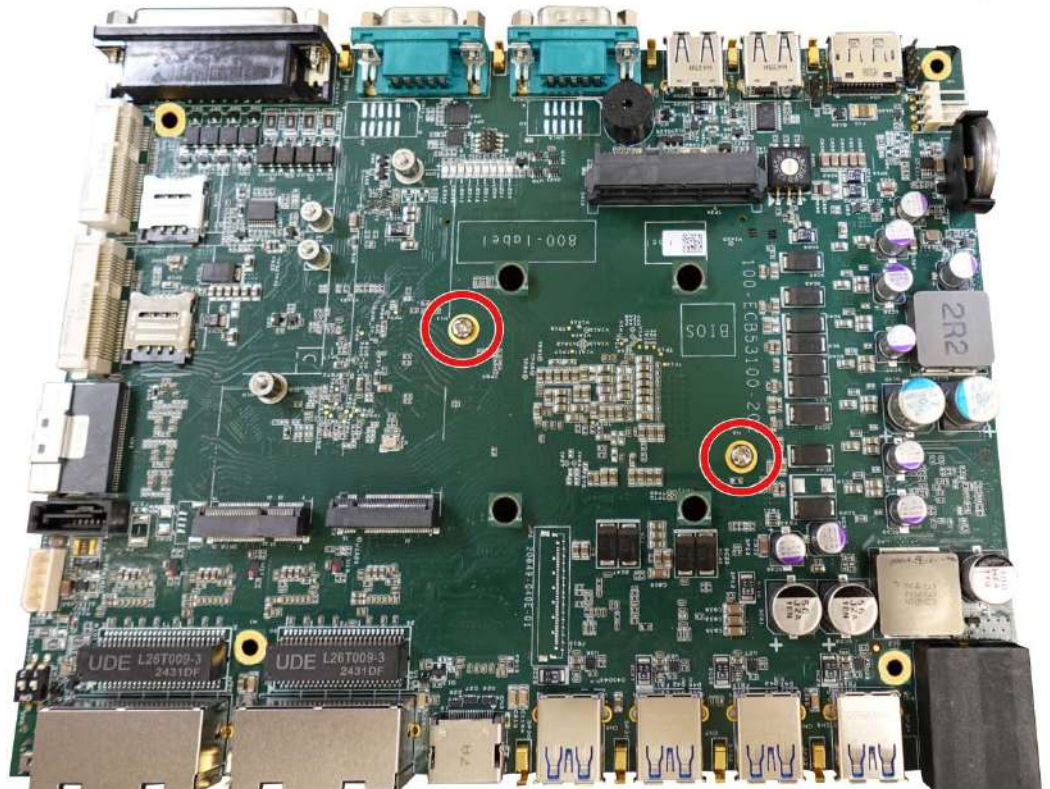

- At this point, the CPU and retention bracket may be stuck onto the heatsink (due to the thermal pad). Please use a plastic pry tool and gently separate the CPU/ holder from the heatsink.

 **WARNING**

With the heatsink, CPU, and retention bracket removed, please be careful when handling the motherboard. DO NOT touch the pins in the LGA socket!

- Gently separate the CPU bracket from the CPU socket, and clean off any thermal pad residues on the CPU IHS and on the retention bracket.

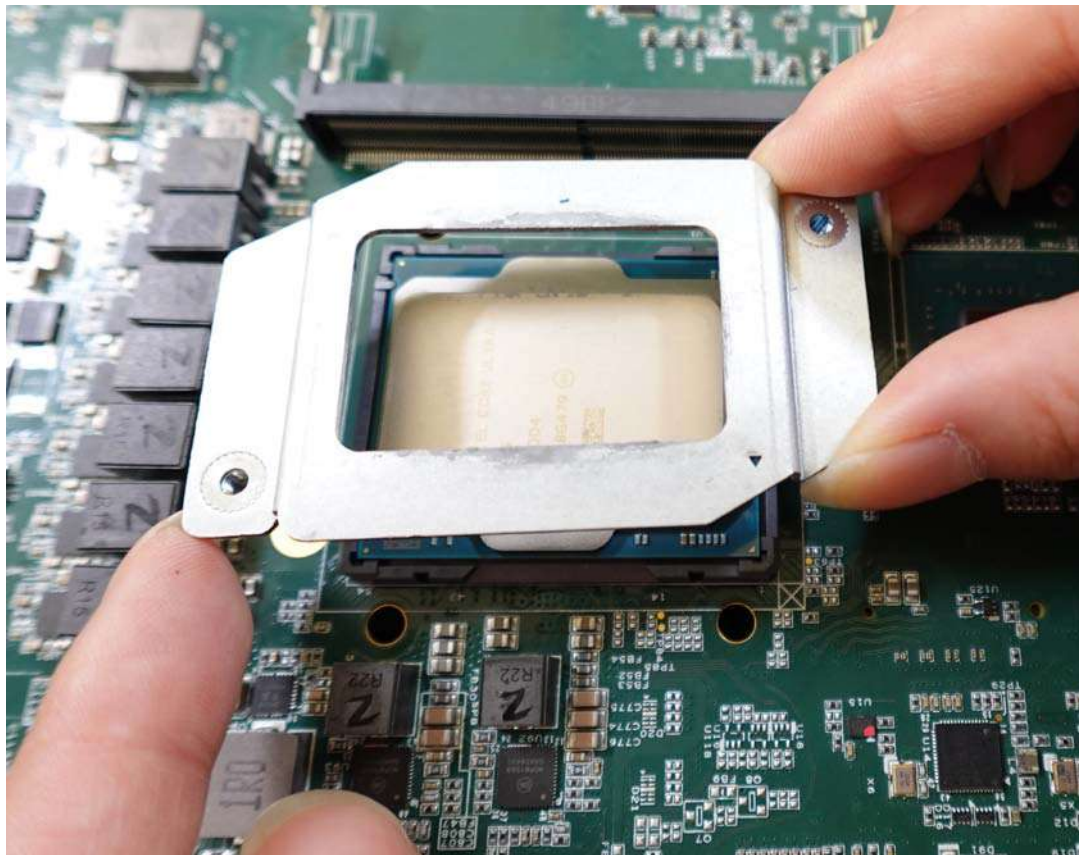

CPU retention bracket (holder)

 **WARNING**

With the CPU removed, please be careful when handling the motherboard. DO NOT touch the pins in the LGA socket!

10. Place a new CPU thermal pad onto the heatsink for the new CPU.

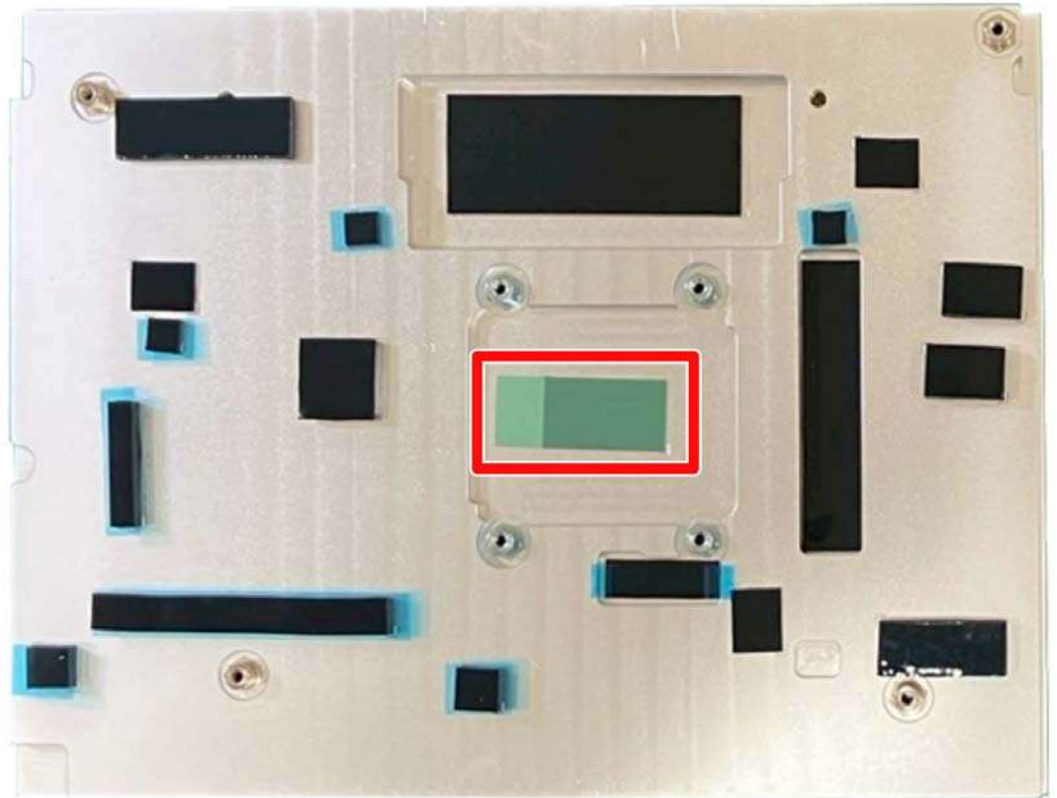

11. Remove and clean off any thermal pad residues around the socket/ motherboard. Gently place the new CPU into the socket by matching the four notches (indicated by blue arrows) on the side to the protrusions in the socket.



12. Make sure all thermal pad residues have been cleaned on both sides of the retention bracket. Place the CPU retention bracket (holder) on top of the CPU and hold it in place. Make sure the indicator triangle engraved on the CPU's integrated heat spreader (HIS) and the triangle indicator on the retention bracket are positioned in the same corner (indicated by **blue circles**).



13. Turn the motherboard around while holding the CPU retention bracket in-place, and secure the bracket by tightening two M3 P-head screws on the other side of the motherboard.

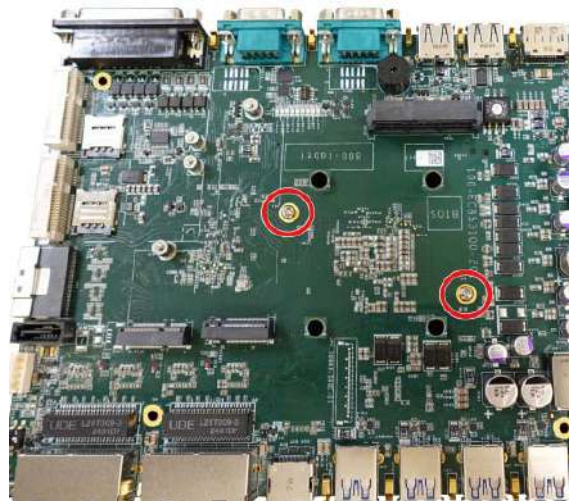
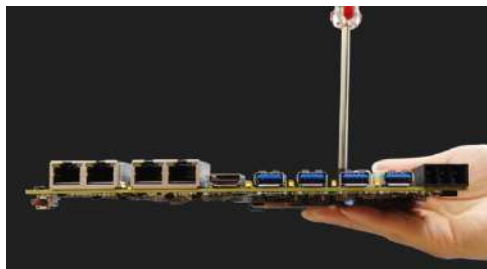

Hold CPU bracket firmly and turn the motherboard around

Secure two M3 P-head screws

14. Remove all thermal pads' protective films on the heatsink, if not already removed.

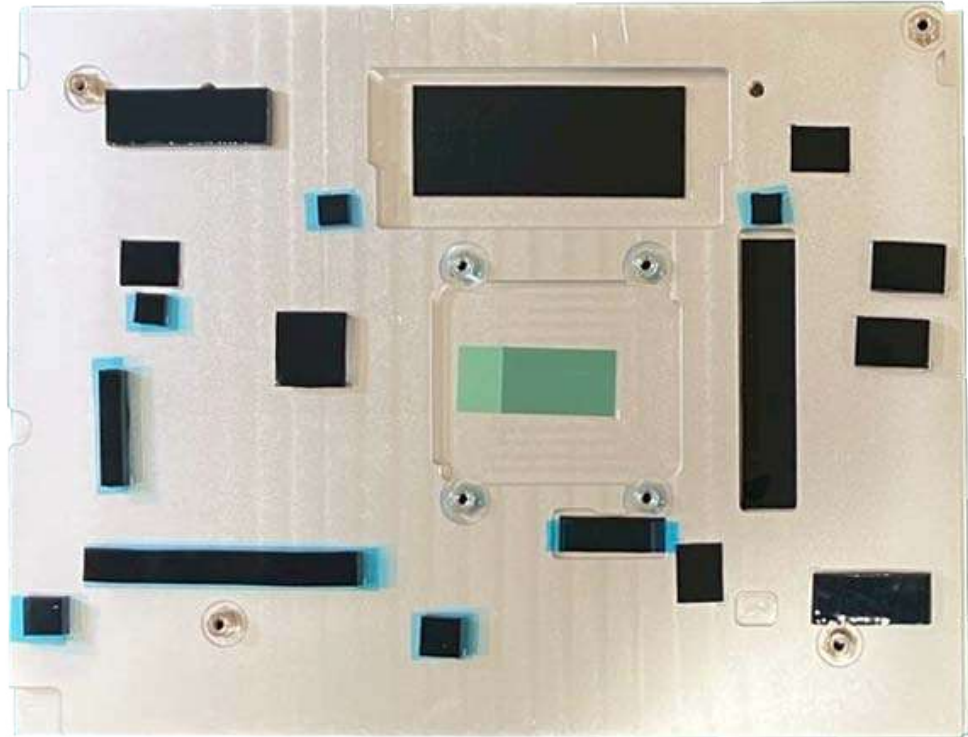

15. With the four motherboard standoffs aligned, gently lower the motherboard onto the heatsink and secure the four screws.

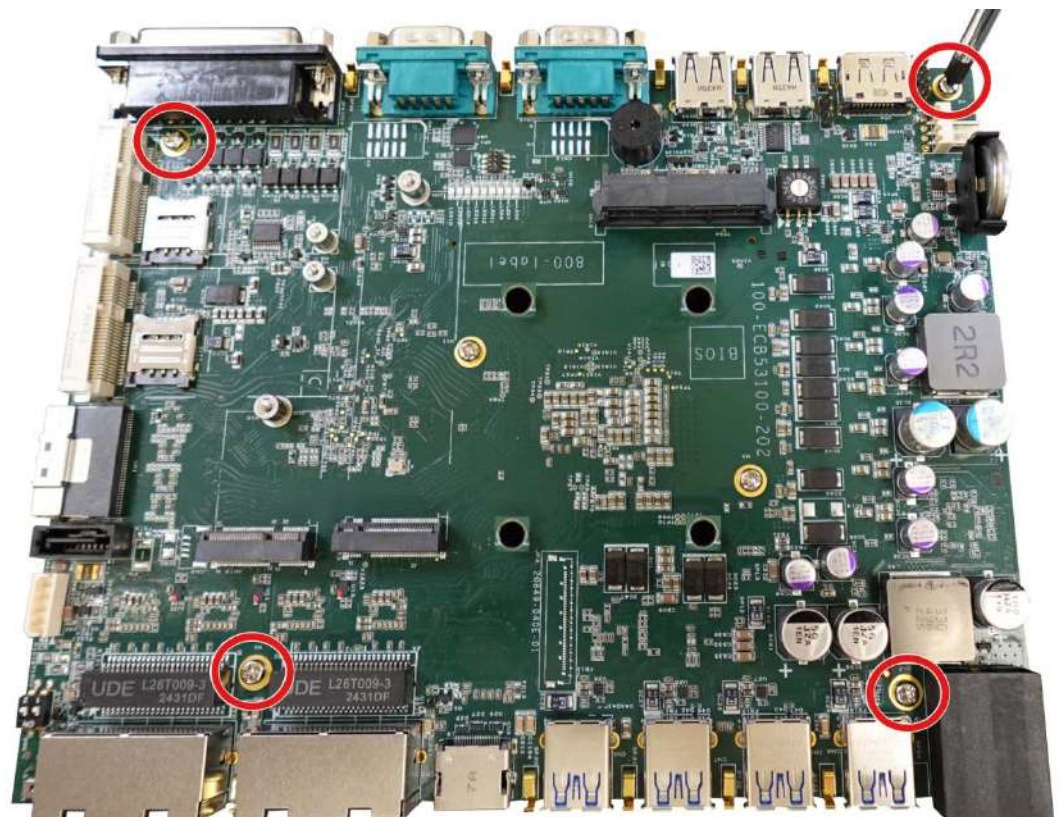

- Once the motherboard has been installed, you're ready to secure the four screws that help the heatsink apply pressure to the CPU/ chipset die. You'll want to apply even pressure to the corners by gradually tightening each screw. Please refer to the recommended order when tightening the screws.

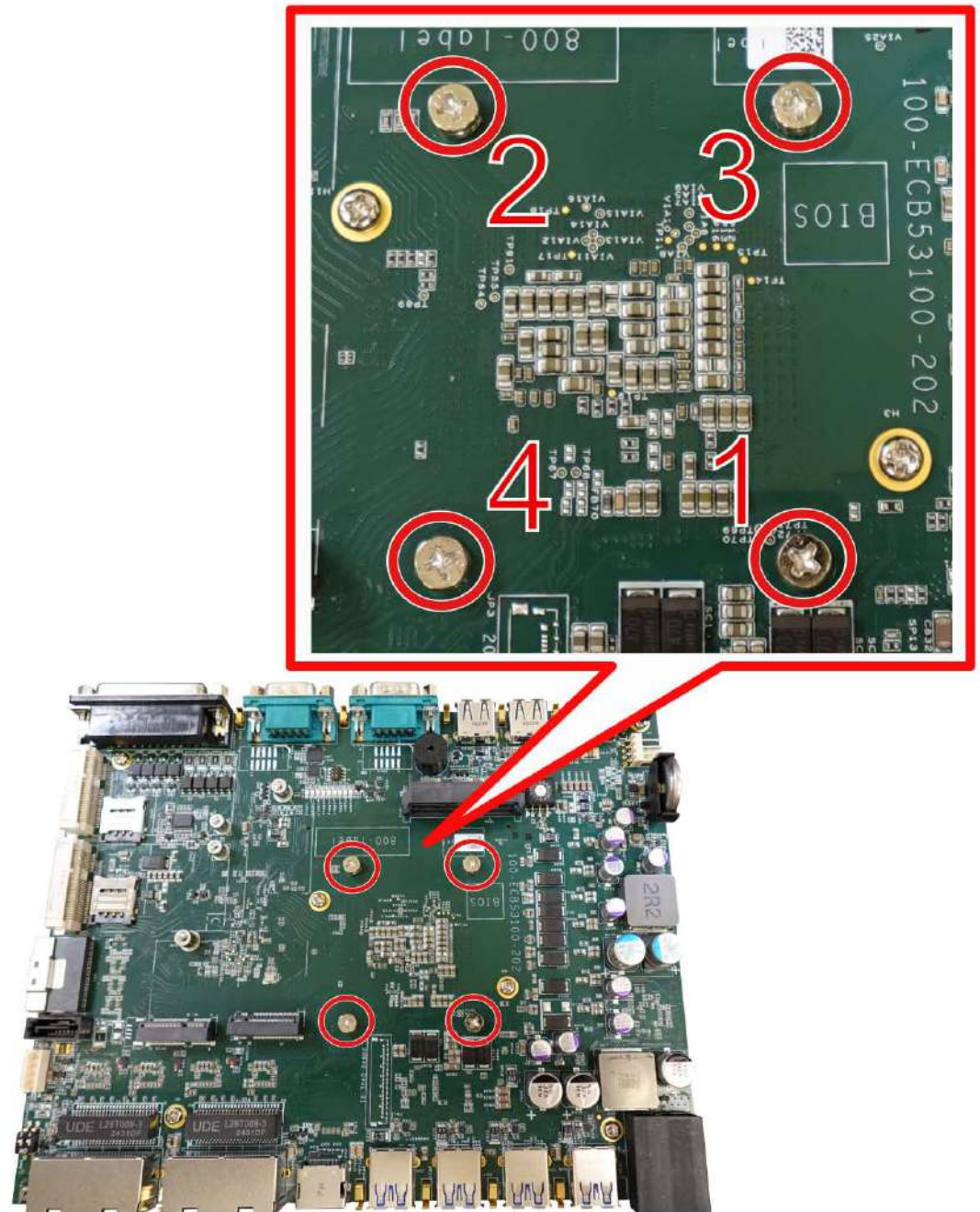

17. Reinstall the two I/O panels. Note the panel insertion on the side.

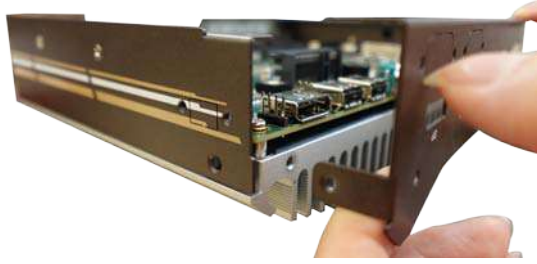

3.2.3 DDR5 SO-DIMM Installation

There is one SO-DIMM memory slot (indicated in **blue**) on the motherboard that supports a total maximum of 64GB DDR5-6400. Please follow the procedures below to replace or install the memory module.

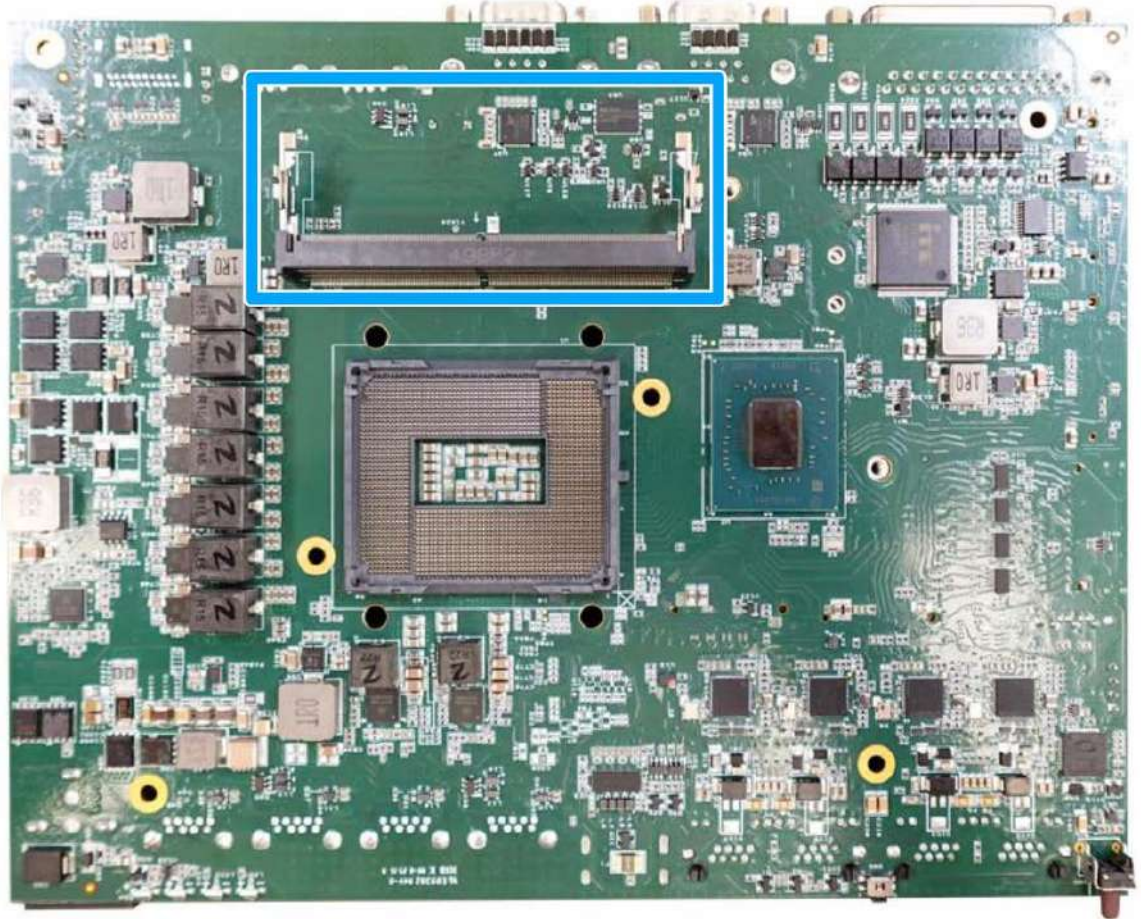

1. Please refer to the section "[Disassembling the System](#)".
2. To replace the existing CPU, you will need to separate the heatsink and the motherboard. To do so, on the I/O panel with the 3-pin terminal block, remove the hexa-screws indicated below.

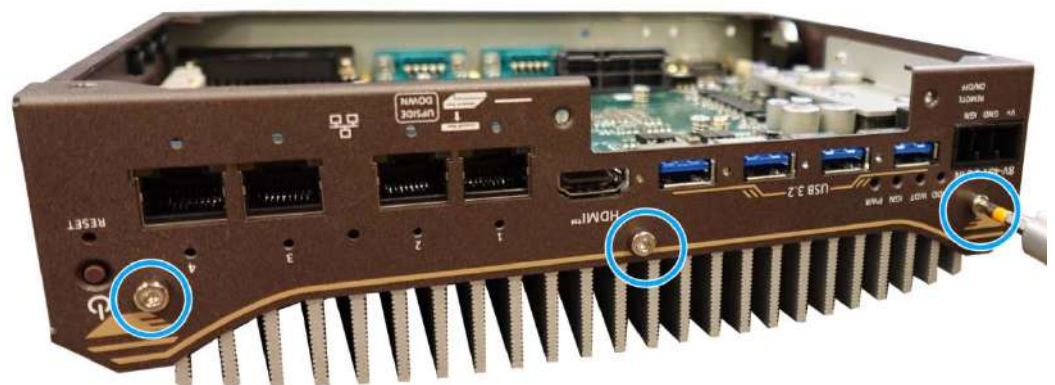

3. On the I/O panel with the DisplayPort, remove the hexa-screws indicated below.

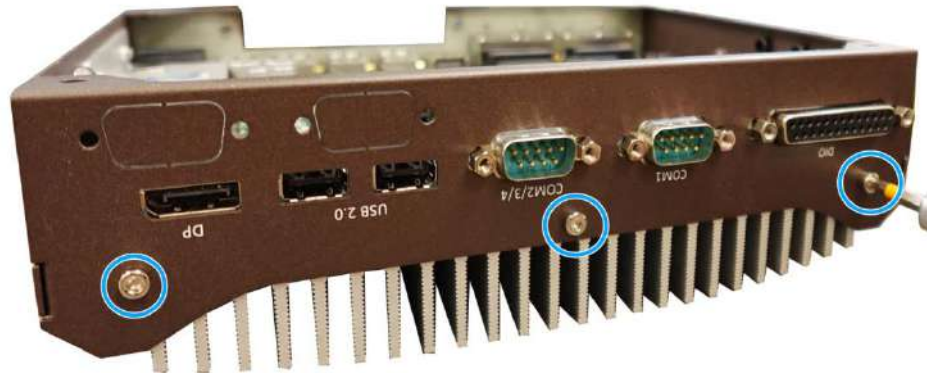

4. Remove the screw indicated on the side panel.



5. Separate the two I/O panels.
6. Remove the eight screws indicated below.

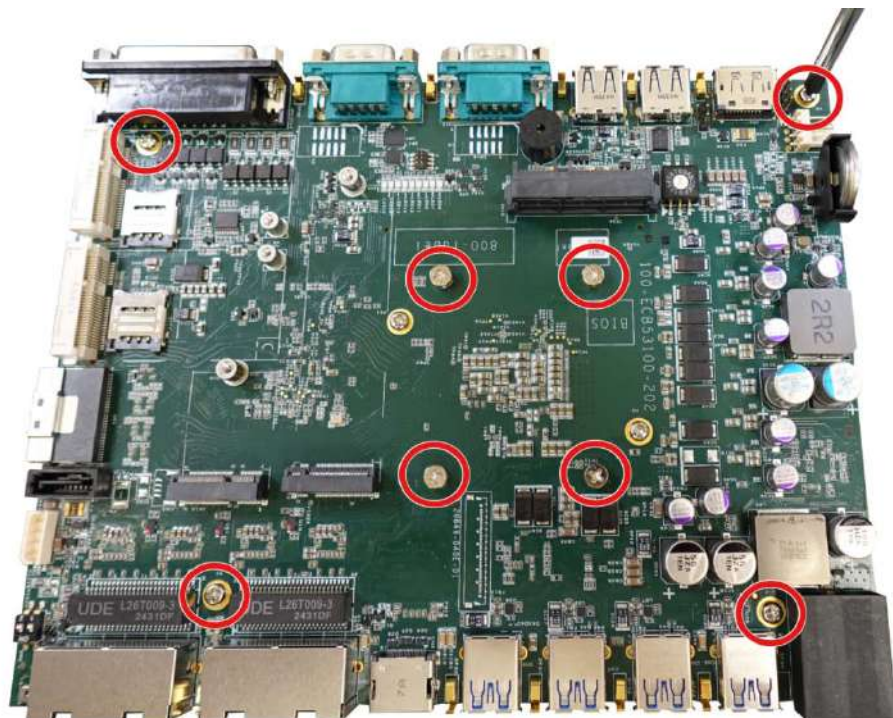

7. Turn over the motherboard once it has been separated from the heatsink. Locate the SODIMM memory module slots on the motherboard.

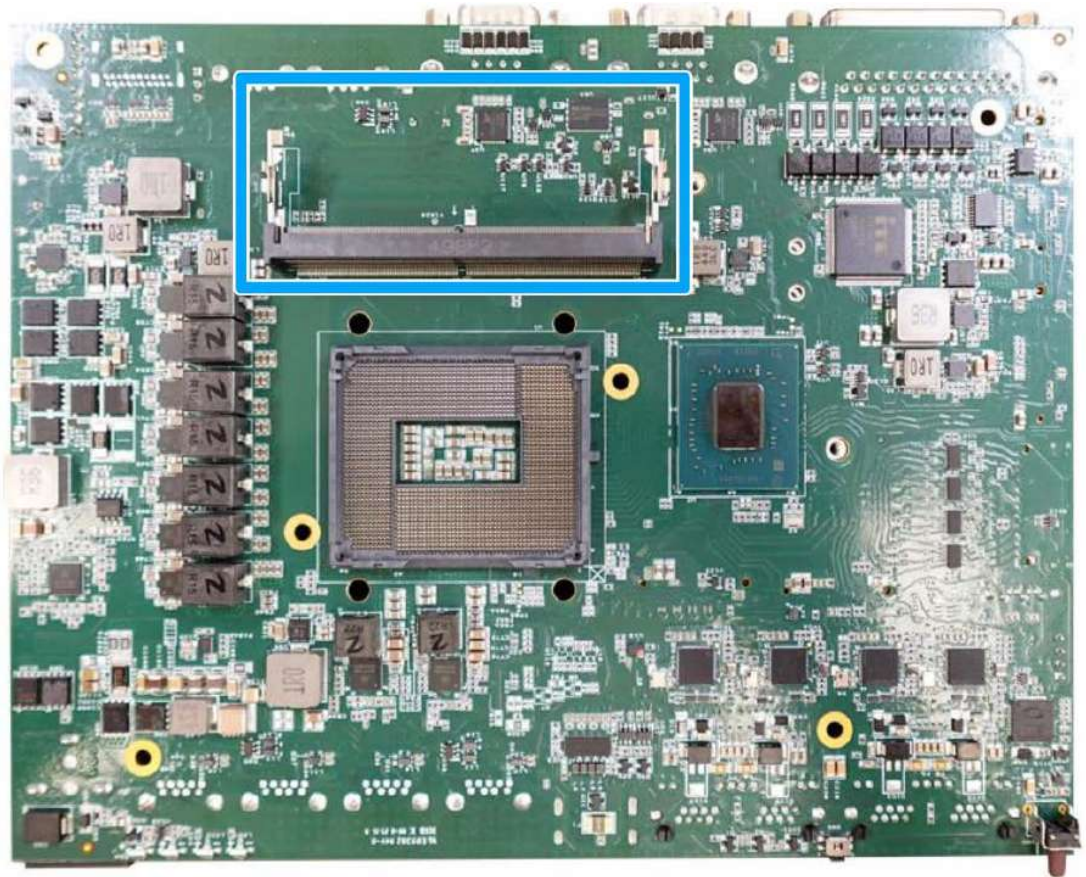

8. To install the memory module, insert gold fingers into the slot at 45-degree angle, push down on the memory module to clip the module into position.



9. Push the memory module down until it is clipped-in.

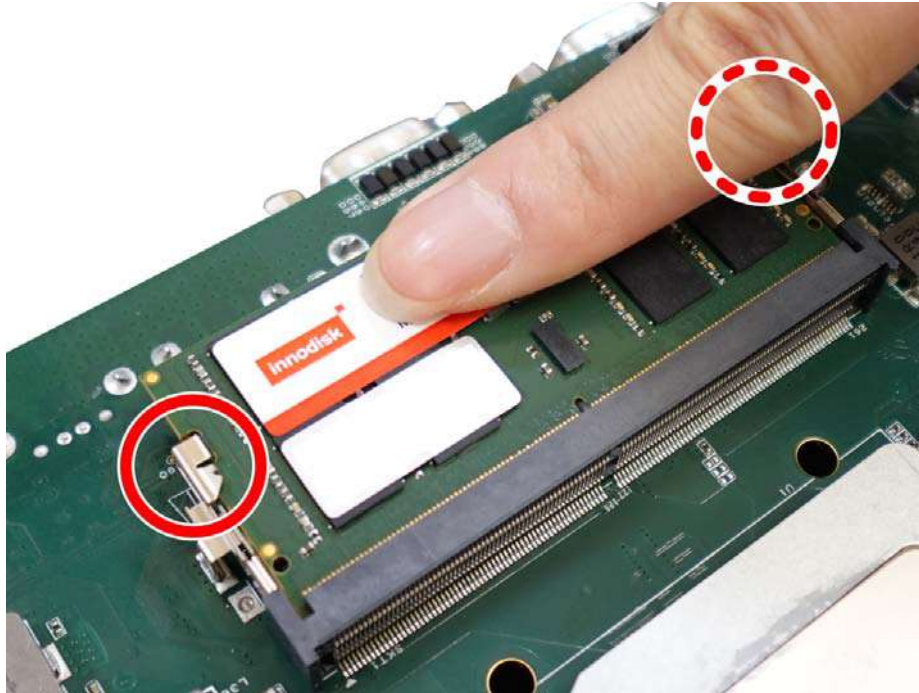

10. Before you reinstall the system enclosure, remove the memory module's thermal pad protective film located on the heatsink.

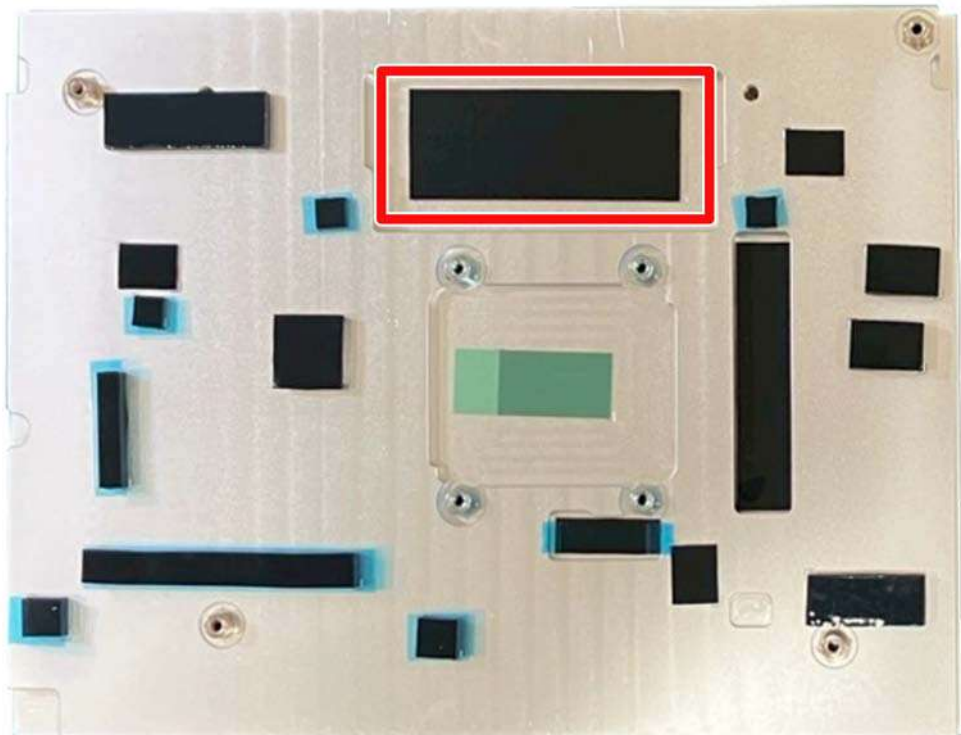

11. Reinstall the motherboard by securing the

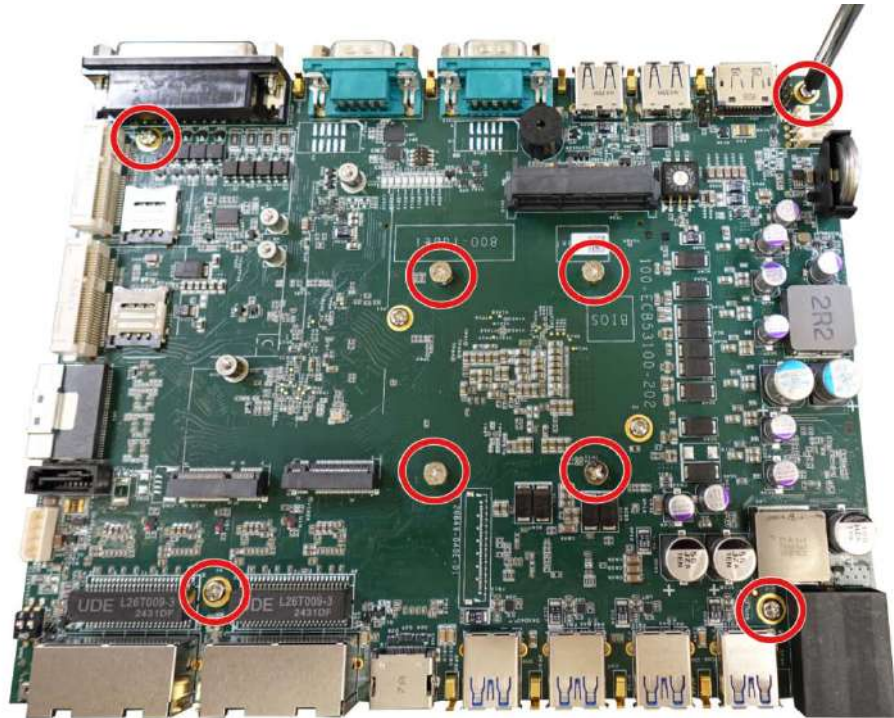

12. Reinstall the two I/O panels. Note the panel insertion on the side.

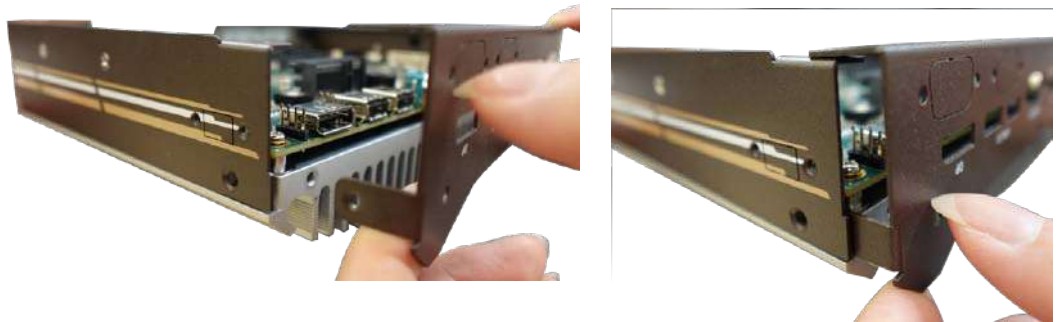

13. Secure the screw indicated.



14. Secure the hexa-screws on both I/O panels.



15. [Reinstall the system enclosure](#) when done.
16. If you need to install other components, please refer to respective sections.

3.2.4 Mini-PCle Module, SIM Card and Antenna Installation

The system has two mPCIe slots (indicated in **blue**) coupled with Micro-SIM socket (indicated in **red**) for installing 3G/ 4G module. Please note that the mPCIe slots are located very close to the M.2 M-key slots, so using an additional mPCIe-to-M.2 adapter may interfere with the M.2 M-key NVMe module. For installation, please refer to the following instructions.

1. Please refer to the section "[Disassembling the System](#)".
2. Locate the mini-PCle and SIM card slots on the motherboard.

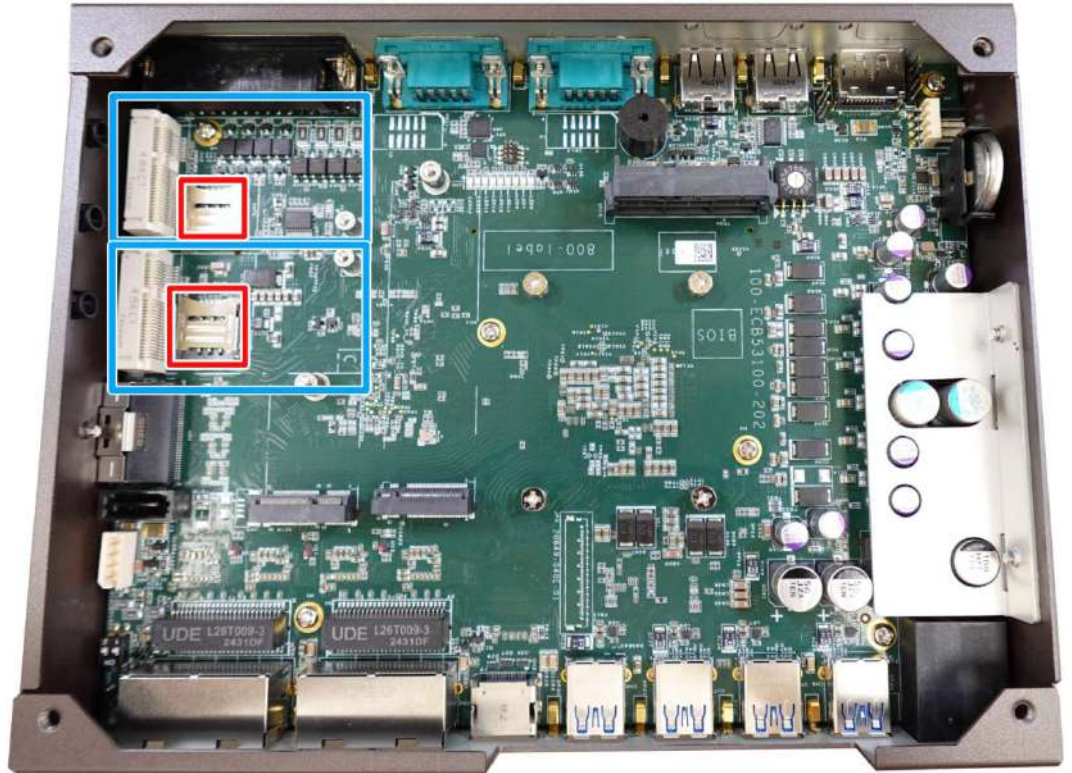

3. If you are installing a wireless module that requires a SIM, please install the SIM card first. Otherwise go to step 5. Push the SIM slot holder in the direction shown and flip open the holder to place the SIM into the slot.



Push the SIM holder in the direction shown **Flip open the holder and place SIM**

- Flip the holder back onto the SIM card and push in the direction shown to lock-in the SIM card into the slot.



- Insert the mPCIe module on a 45 degree angle into the mPCIe slot and secure the module.



Insert on 45 degree angle



Secure the module

- Clip on the IPEX-to-SMA cable to the module and secure the antenna to the front or rear panel. Please refer to the module's manual for clip-on connection.



Clip on IPEX-to-SMA cable

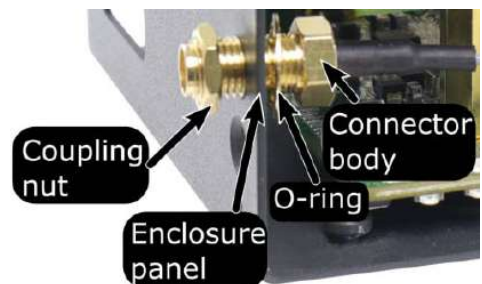

Secure antenna to panel

- Repeat the above steps if you need to install the second mini-PCIe module.
- [Reinstall the system enclosure](#) and panel when done.
- If you need to install other components, please refer to respective sections.

3.2.5 M.2 2230 E-Key Module Installation

The system has an M.2 2230 E-key slot for installing wireless WiFi module. For installation, please refer to the following instructions.

1. Please refer to the section "[Disassembling the System](#)".
2. Locate the M.2 2230 E-Key slot (**red rectangle**) on the motherboard.

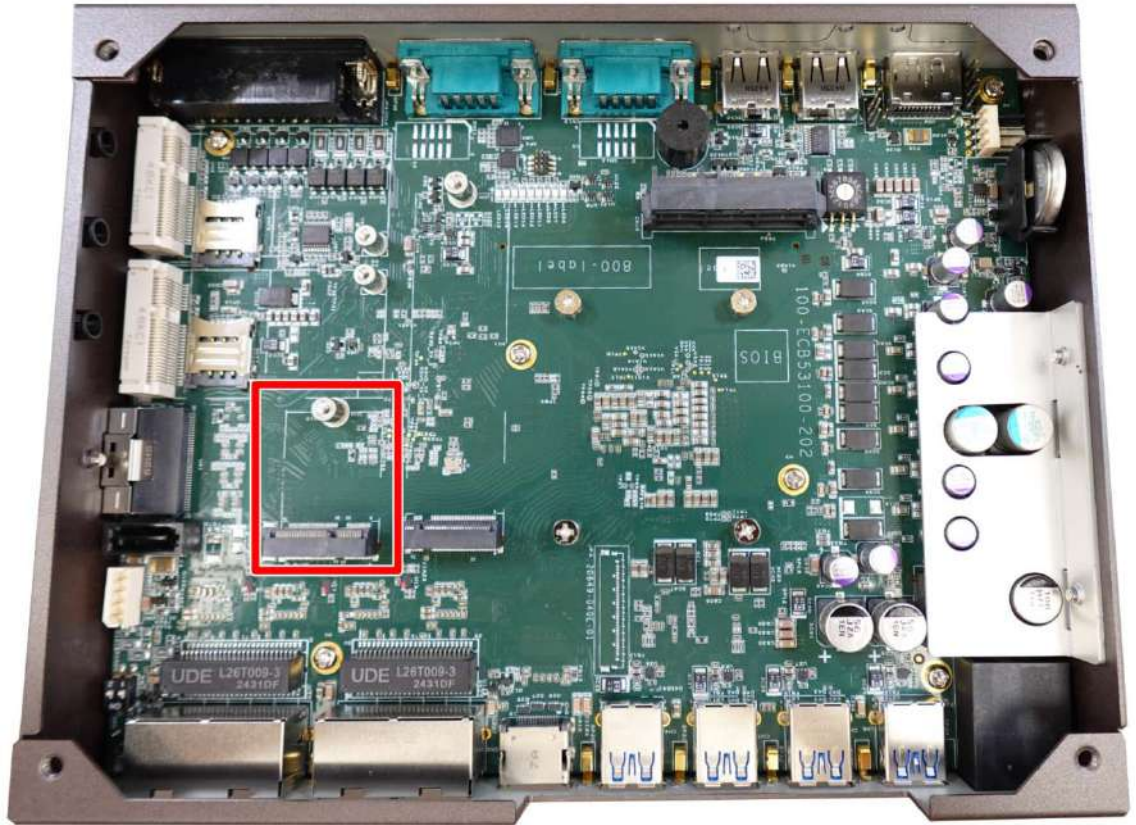

3. Insert the module on a 45 degree angle.



- Gently press down and secure the module with an M2.5 P-head screw.



- Clip on the IPEX-to-SMA cable to the module and secure the antenna to the front or rear panel. Please refer to the module's manual for clip-on connection.



Clip on IPEX-to-SMA cable

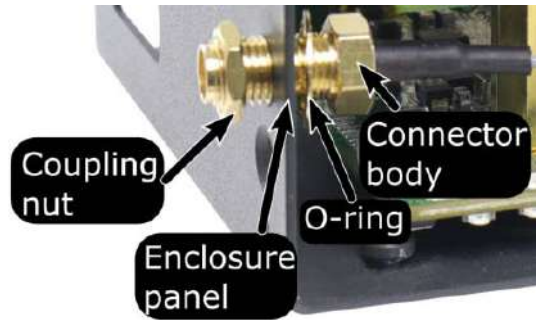

Secure antenna to rear panel

- Remove the thermal pad indicated for the M.2 module.

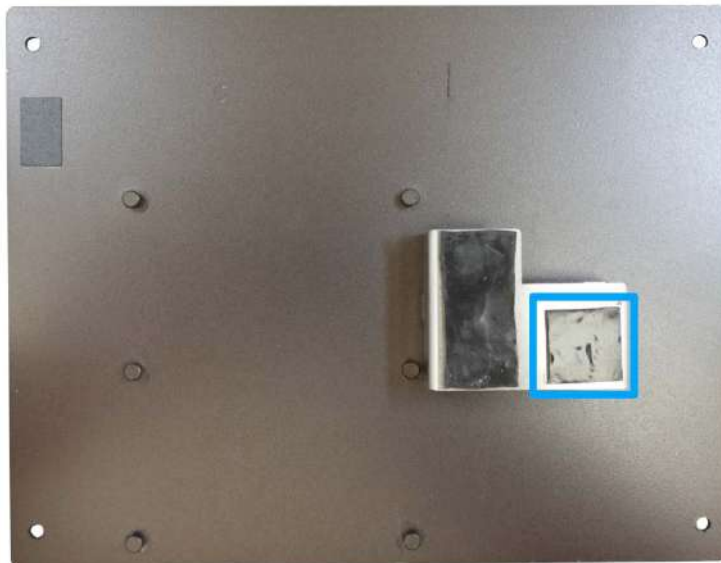

- [Reinstall the system enclosure](#) and panel when done.
- If you need to install other components, please refer to respective sections.

3.2.6 M.2 2280 NVMe SSD Installation

The system has a Gen4 x4 PCIe M.2 2280 slot for you to install an NVMe SSD. For installation, please refer to the following instructions.

1. Please refer to the section "[Disassembling the System](#)", you may not need to completely dismantle the system to gain access to the M.2 slot.
2. Insert the module on a 45 degree angle.

3. Gently press down and secure the module with an M2.5 P-head screw.



4. Remove the thermal pad's protective film at the bottom of the enclosure panel for the NVMe module.

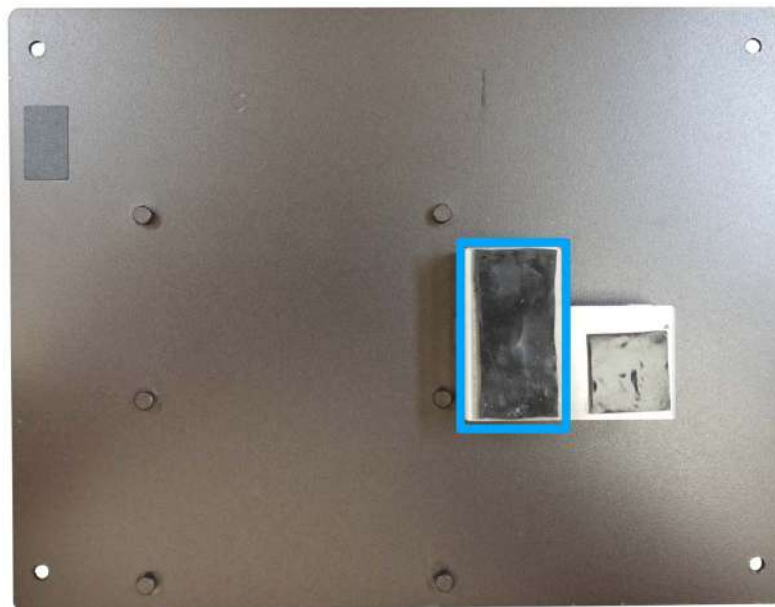

5. [Reinstall the system enclosure](#) and panel when done.
6. If you need to install other components, please refer to respective sections.

3.3 Installing the System Enclosure

1. To reinstall the system enclosure, turn the system upside down, place the bottom panel back onto the system.

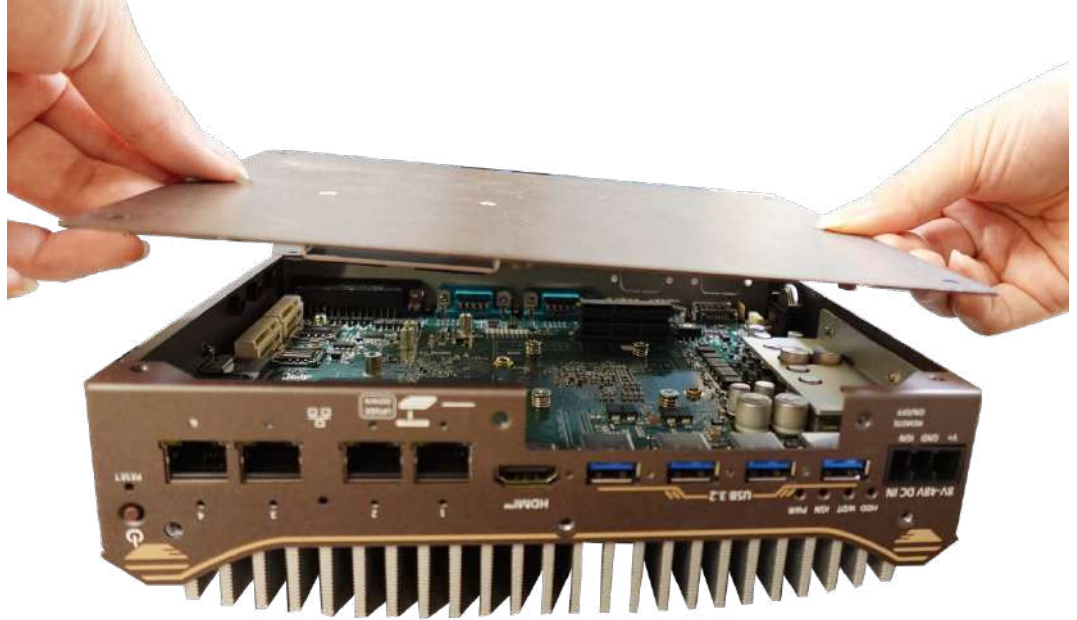

2. Secure the screws indicated.



3. Insert the 2.5" easy swap tray back into the system and secure the thumb screws to complete the enclosure installation.

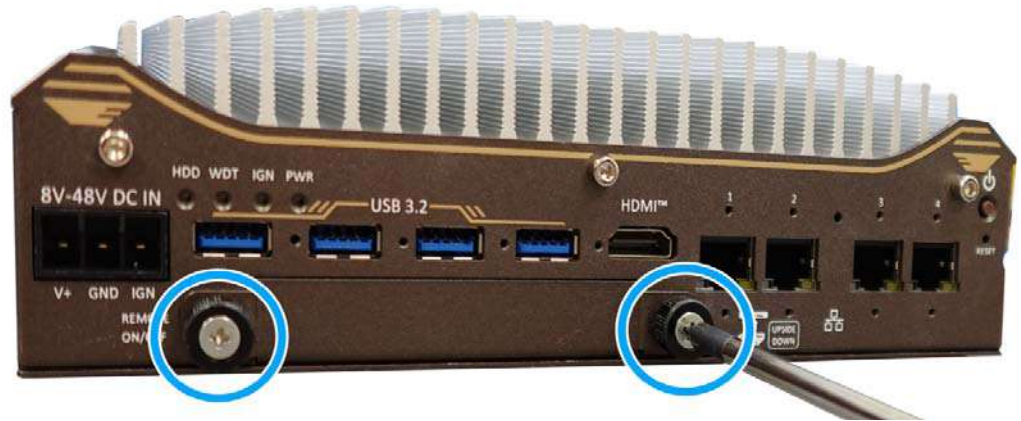

3.4 2.5" Easy Swap Tray HDD/ SSD Installation

NOTE

Supports up to 7mm thickness 2.5" HDD/ SSD.

The system has a 2.5" easy swap tray that supports a 2.5" HDD/ SSD up to 7mm thickness. Please refer to the following instructions on how to install 2.5" SATA HDD/SSD.

1. Turn the thumb screws anti-clockwise and take out the tray.

2. Secure the 2.5" HDD/ SSD onto the tray with four M3 P-type screws from the screw pack (two on each side). Note that the 2.5" HDD/ SSD needs to be positioned upside down.



3. Reinsert the 2.5" tray back into the system, there may be some resistance when the SATA connector meets the drive. Push the 2.5" tray in and turn the thumb screws clockwise to secure the 2.5" tray in place.



4. If you need to install other components, please refer to respective sections.

3.5 Ethernet/ PoE+ Port Panel Screw Fix

The system's Ethernet ports have panel screw fix holes (indicated in red) to secure the cable connection.

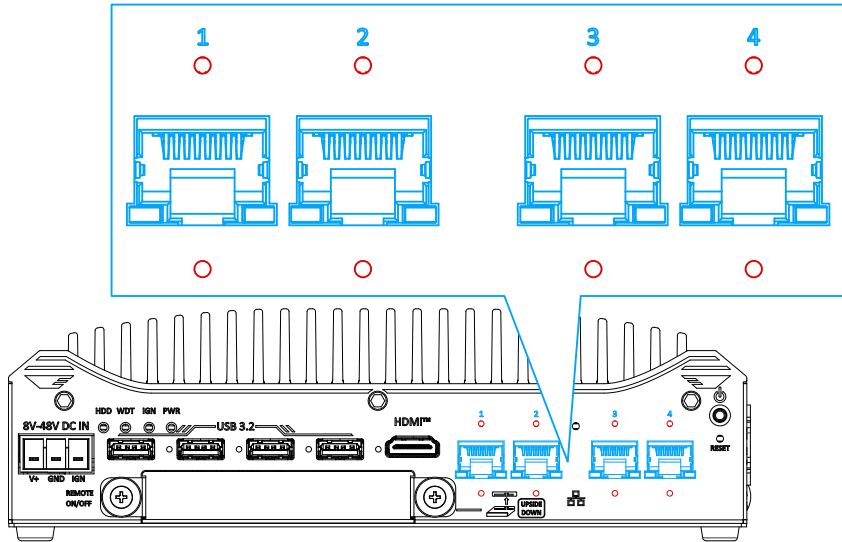

To install and make use to the panel screw fix connection, you must acquire panel screw fix cables such as the cable shown below.



Simply insert the RJ45 connector into the RJ45 port and secure the top and bottom screws using your fingers or a screw driver.



3.6 Wall Mount Bracket/ DIN-rail Installation



NOTE

You will need to remove the four (4) rubber stands at the bottom of the enclosure if they have been attached.

3.6.1 Wall Mount Bracket Installation

To install the system as a wall mount device, please refer to the following instructions.

1. Take out the two wall mount brackets (indicated in **blue**) and four M4 screws out of the accessory box. Fix the wall mount brackets to the system enclosure using M4 screws (indicated in **red**).

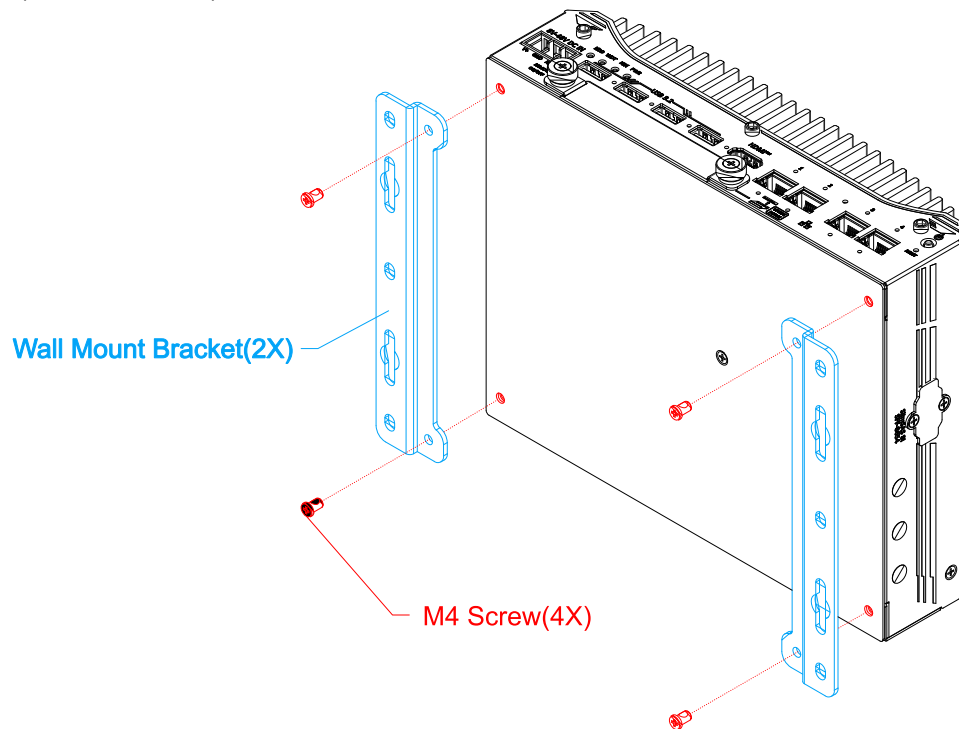

2. Place the system on a flat surface portion of the wall and secure it with four (4) M4 screws.
3. When wall mounting, place the heatsink fins perpendicular to the ground for better heat dissipation efficiency.

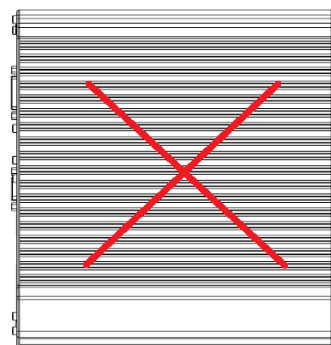
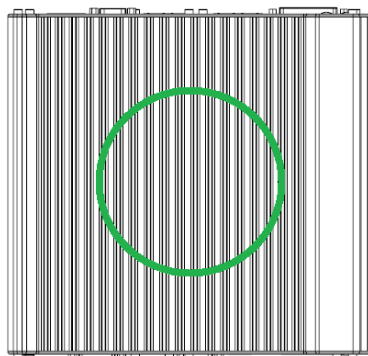

3.6.2 DIN-rail Installation (Optional)

The system also has an optional DIN-rail mounting kit. The kit includes a bracket (in **blue**) and a DIN-rail mounting clip (in **red**). By fixing the clip to the bracket using four M4 flat-head screws (in **green**) and fixing the bracket assembly to the system four M4 screws (in **green**), complete the installation by clipping the system onto the DIN rail. This option may be useful if you want to deploy it inside an equipment cabinet where DIN rail is available.

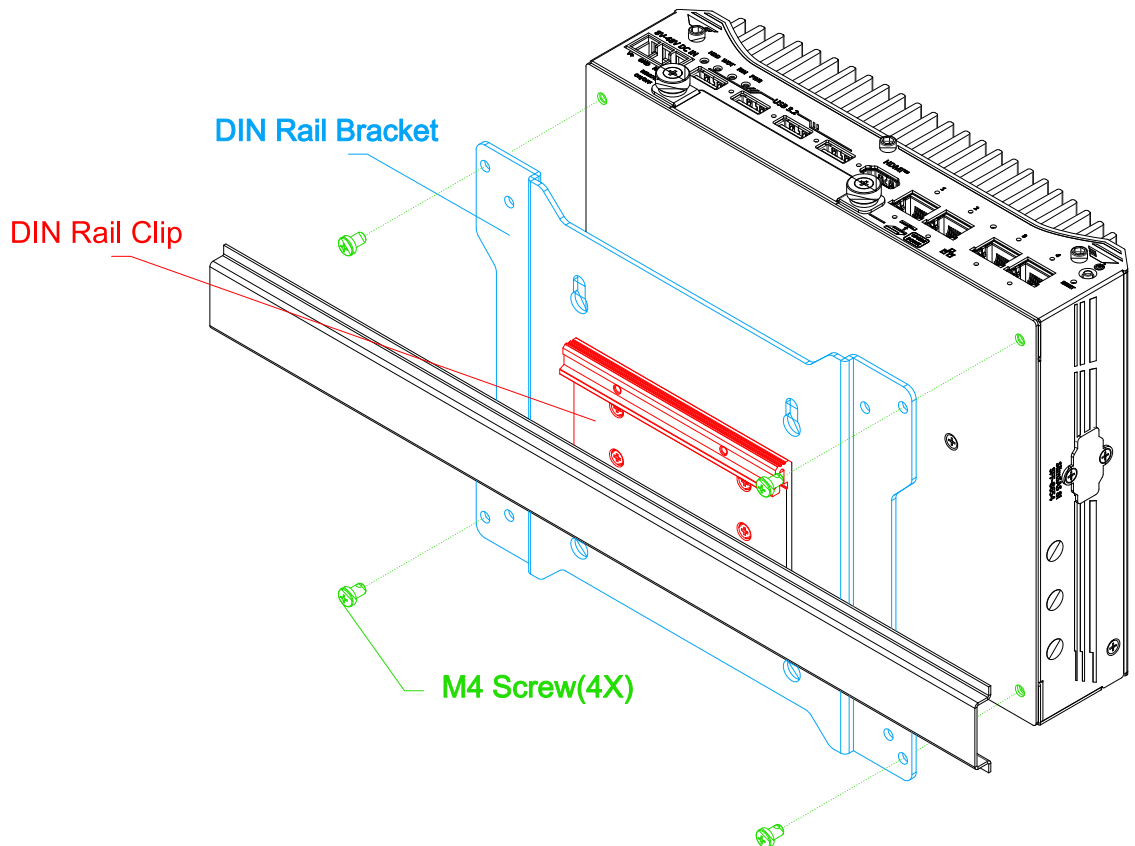

3.6.3 Fan Kit Installation (Optional)

If you have set the CPU to operate at 65W TDP, and the system will be deployed in an ambient temperature of 50°C or more, it is recommended to purchase and install the optional fan kit.

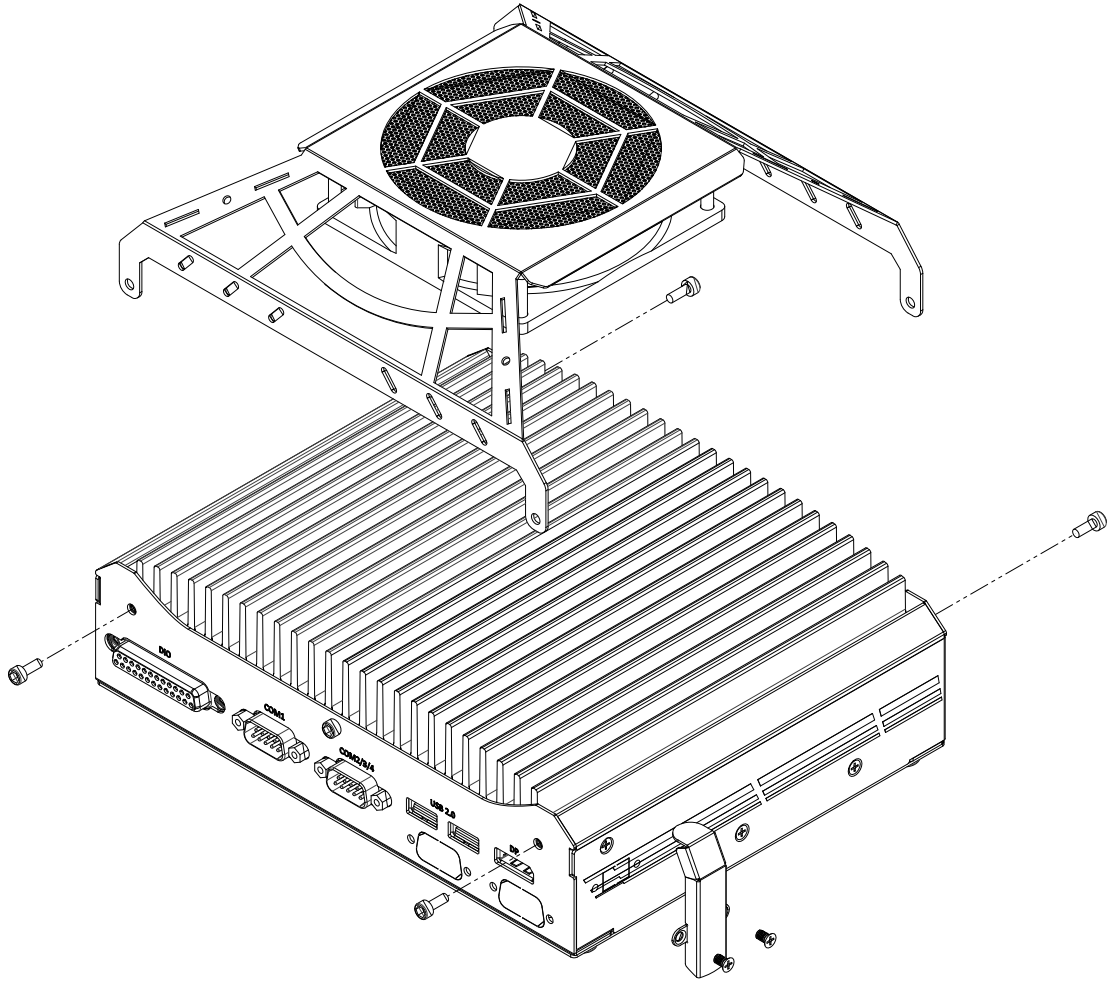

Exploded view of the fan kit

To install a fan kit, please refer to the following instructions:

1. Please refer to the section "[Disassembling the System](#)".
2. From the inside the side panel, push out the "punch-out" panel indicated. The fan's power cable will enter through this punch-out panel.

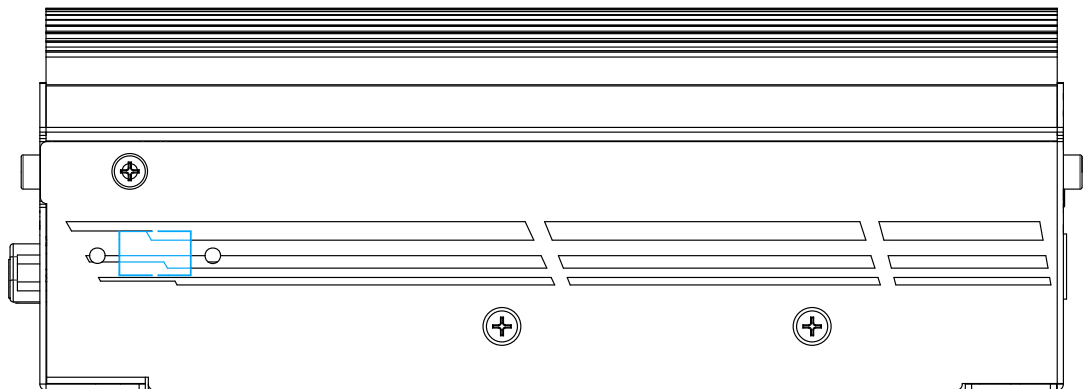

3. Remove the I/O panel screws indicated

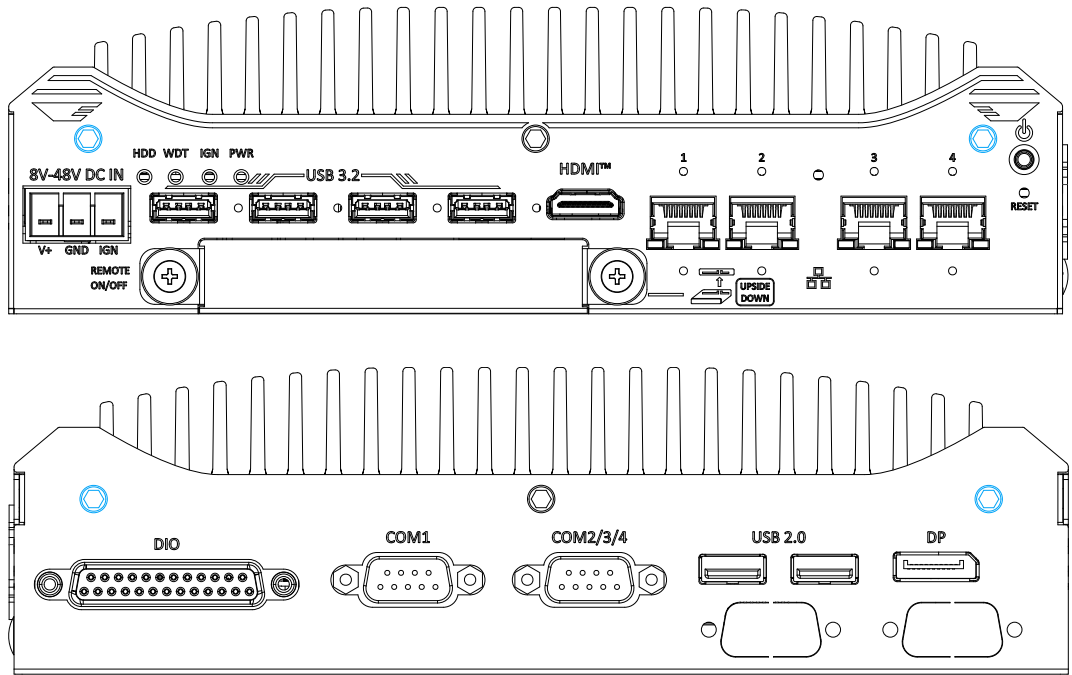

4. Lower the fan on top of the system, make sure the orientation of the fan allows the fan's power cable to be on the same side as the punch-out panel, and secure the two hexa-screws on both sides of the I/O panel.

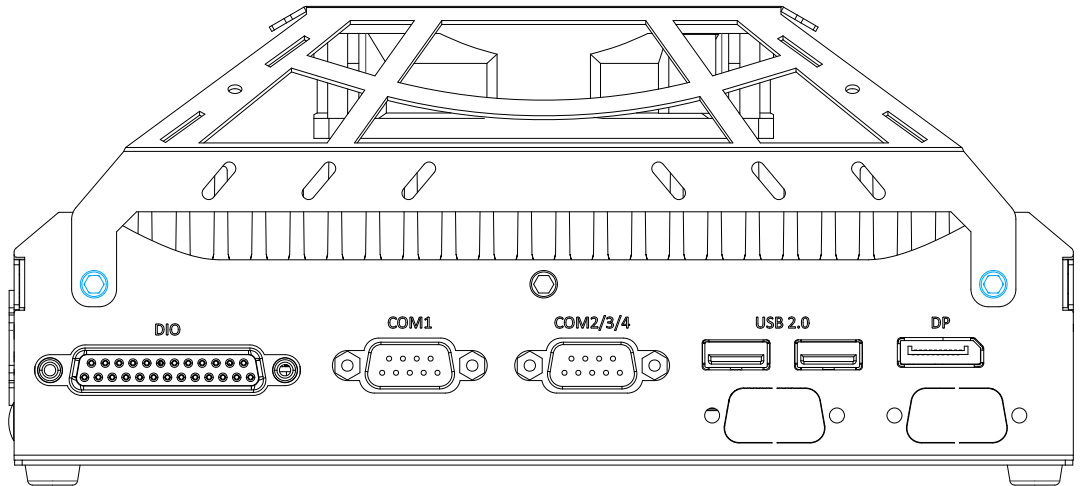
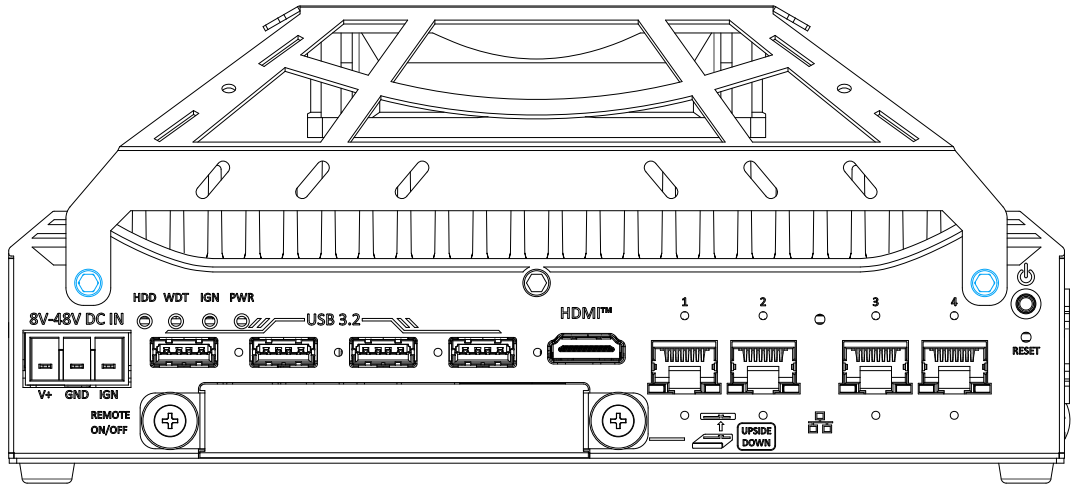

5. Insert the fan's power cable into the punch-out panel and plug it into the 4-pin connector indicated on the motherboard.

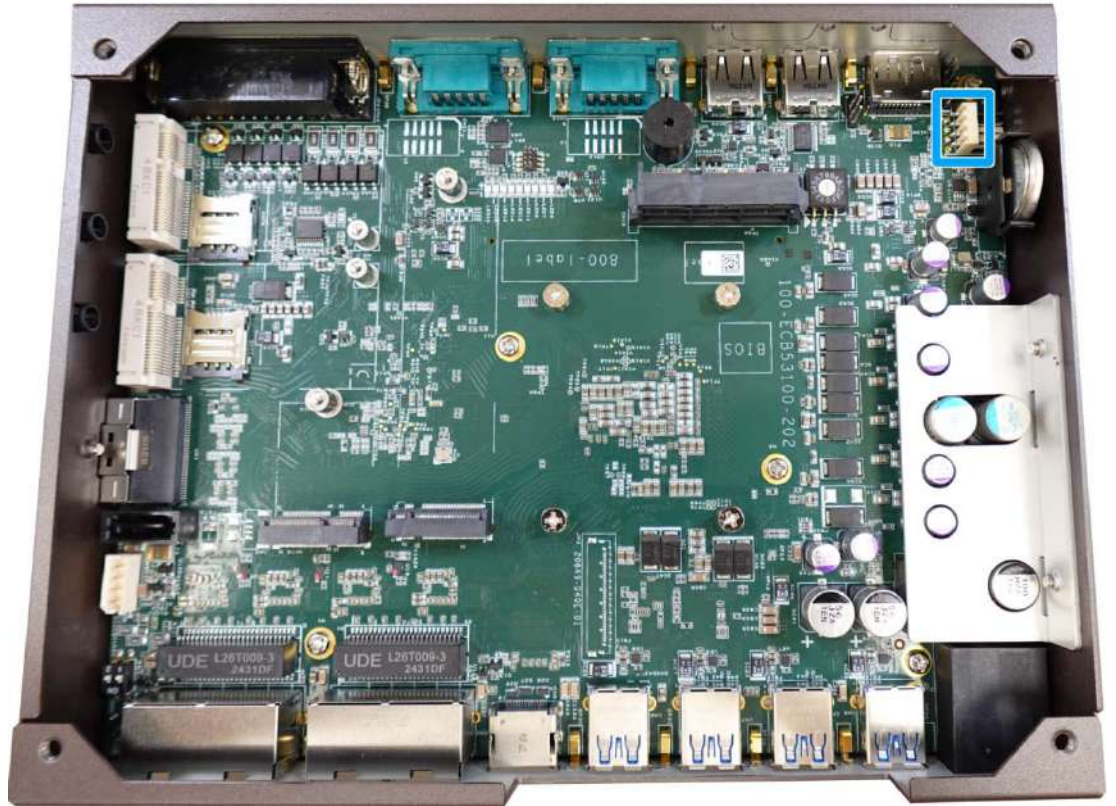

6. Place the cable cover (indicated in blue) over the fan's power cable and secure it with the two screws (indicated in red).

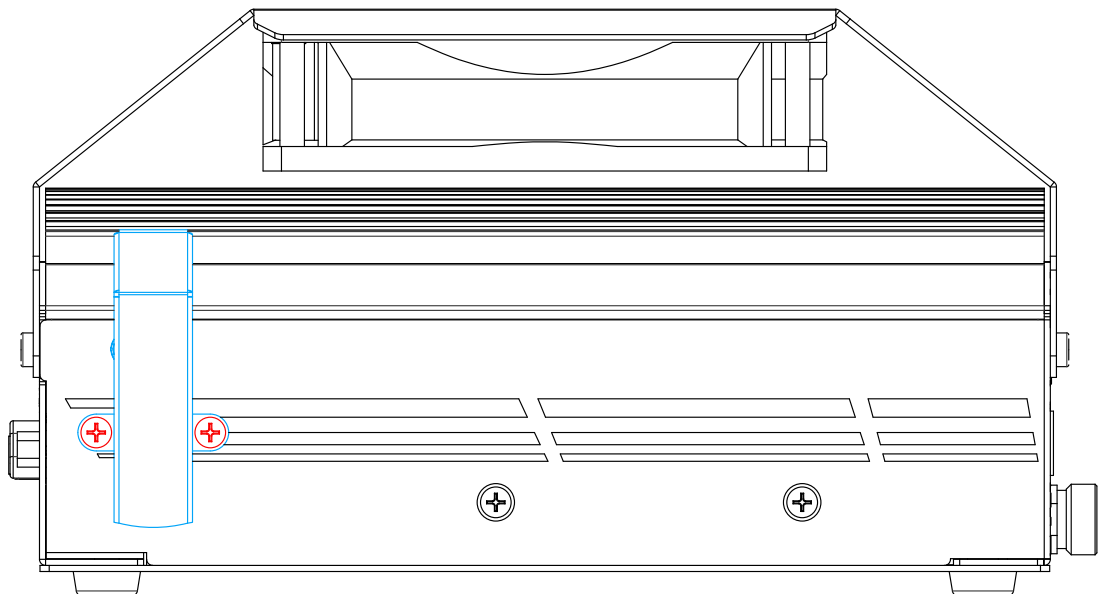

7. Place the bottom panel back onto the system.

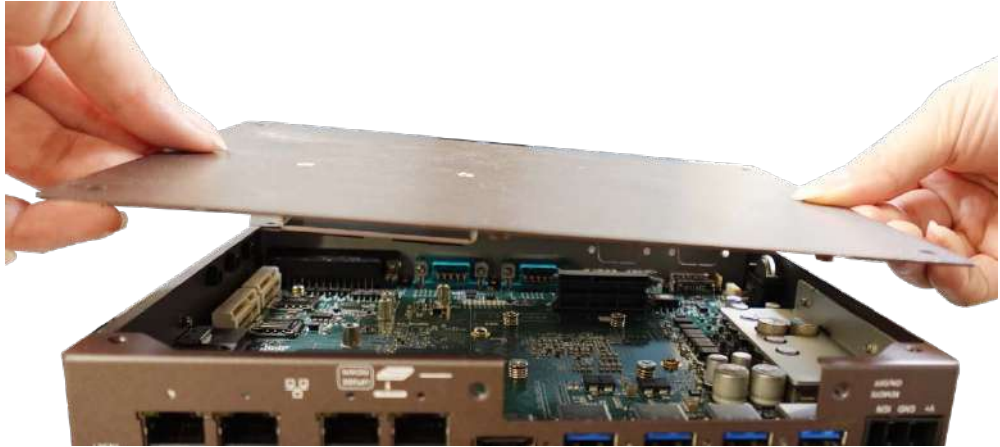

8. Secure the screws indicated.



9. Insert the 2.5" easy swap tray back into the system and secure the thumb screws to complete the enclosure installation.



3.7 Powering On the System

There are three methods to power on the system

- Pressing the power button
- Using an external non-latched switch by connecting to the remote on/ off plug
- Sending a LAN packet via Ethernet (Wake-on-LAN)

3.7.1 Powering On Using the Power Button

This is the simplest way to turn on your system. The power button on the front panel is a non-latched switch and behaves as the ATX-mode on/off control. With DC power connected, pushing the power button will turn on the system and the PWR LED indicator will light up. Pushing the button when system is on will turn off the system. If your operating system supports ATX power mode (i.e. Microsoft Windows or Linux), pushing the power button while the system is in operation will result in a pre-defined system behavior, such as shutdown or hibernation.

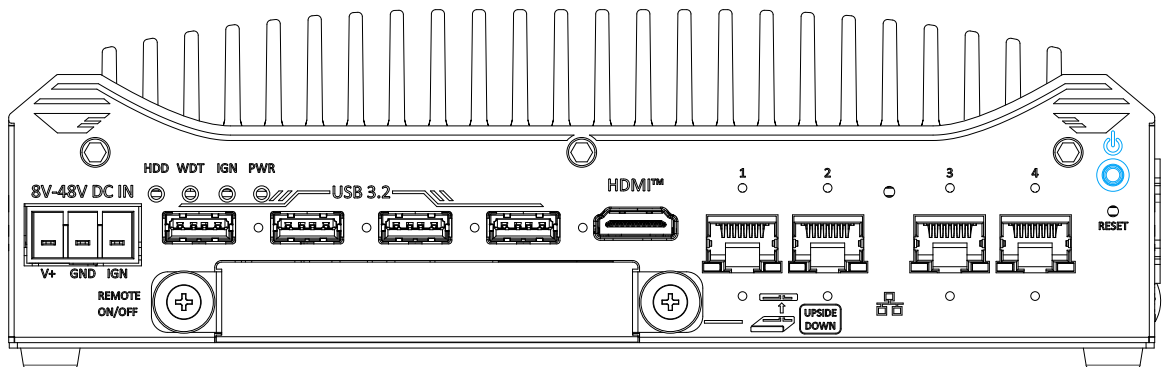

3.7.2 Powering On Using External Non-latched Switch

If your application demands the system to be placed inside a cabinet, you may use an external non-latched switch to power on/ off the system. The system provides a 3-pin “Remote On/ Off” plug for connecting a non-latched switch and acts as the ATX-mode power on/off control switch. The external non-latched switch acts exactly the same as the power button on the front panel. To setup and power on/ off the system using an external non-latched switch (ATX-mode), please follow the steps described below.

1. Acquire a non-latched switch and connect it to the **IGN/Remote on/off** and **V+** pins on the 3-pin power connector.
2. Press the power button on the non-latched switch to short the **IGN/Remote on/off** and **V+** pins. Hold for at least one second and release the button.

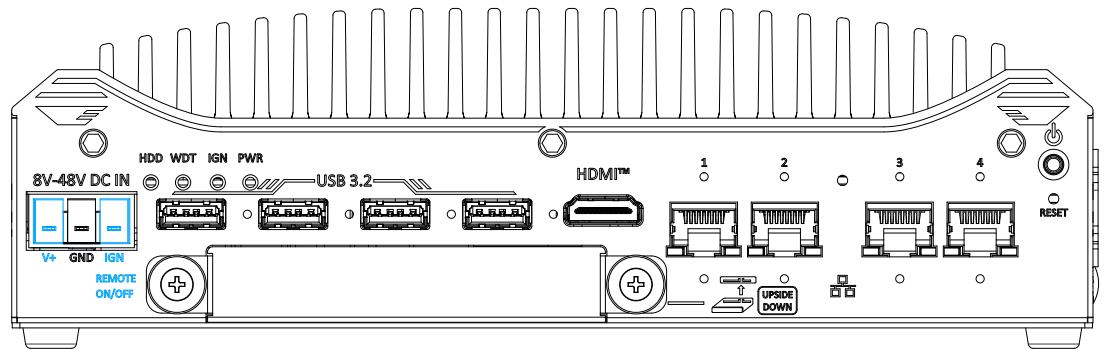

3. When the system is powered on, you may press and hold the power button (for at least one second) on the non-latched switch to turn off the system, or to execute a pre-defined action.

3.7.3 Powering On Using Wake-on-PME (Wake-on-LAN)

Wake-on-PME (WOL) is a mechanism to wake up a computer system from a S5 (system off with standby power) state via issuing a magic packet. The system's Wake-on-PME compatible port is shown below.

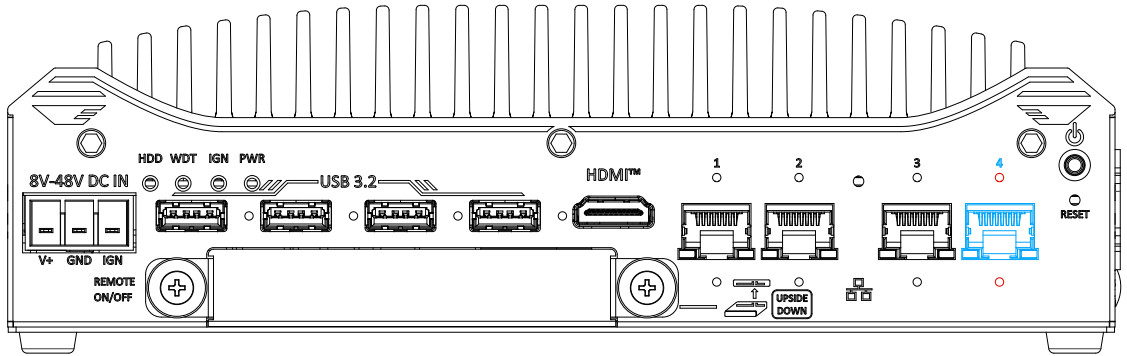

NOTE

Please make sure the Intel® chipset and Ethernet driver has been properly installed prior to setting up Wake on PME function.

To enable this function, please set up Wake on PME settings in the BIOS and in the operating system by follow the steps described below.

1. When the system boots up, press F2 to enter BIOS setup utility.
2. Go to the **[Power]>[Wake On PME]** and set it to **[Enabled]**.

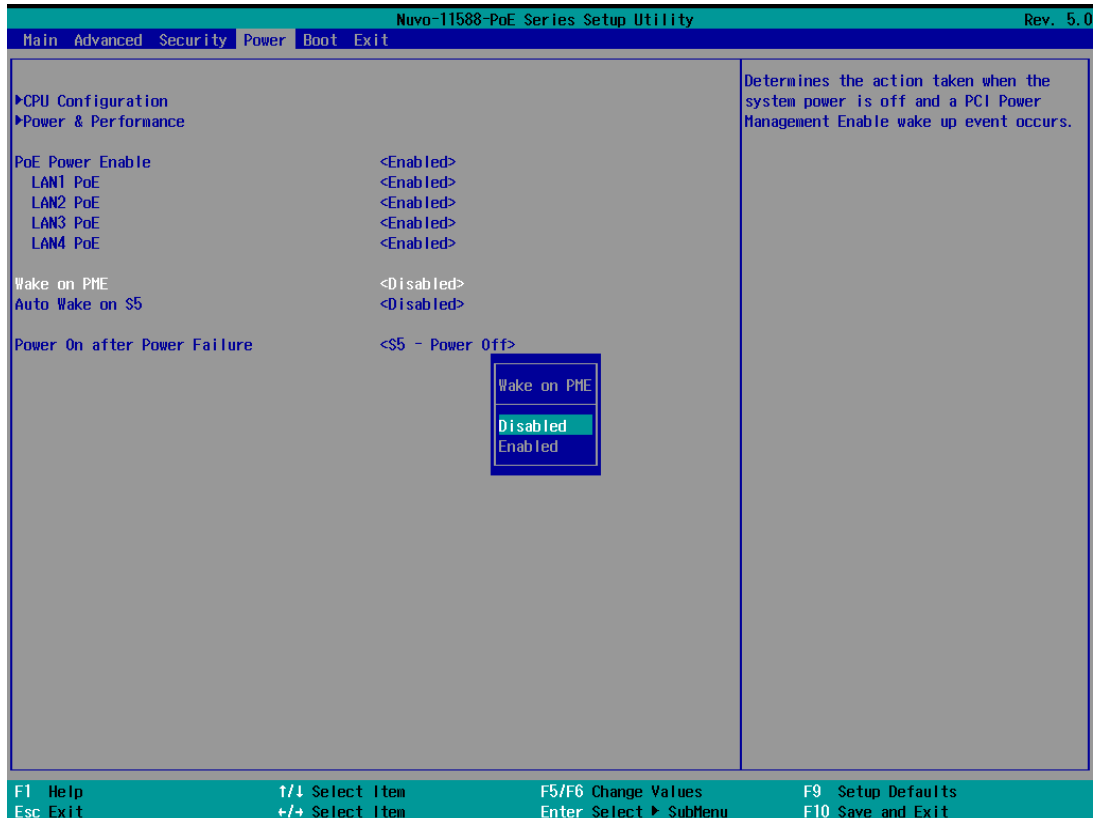

3. Press F10 to **“Save changes and exit BIOS”** and allow the system boot into the operating system.
4. Once booted into the Windows system, press **“Windows key + E”**, right-click on **“Network>Properties>Change adapter settings”**. Locate and double-click on the adapter Intel® Gigabit Network Connection, click on **Configure...**
5. Click on the **Power Management** tab and check the following options. Click on OK when done.

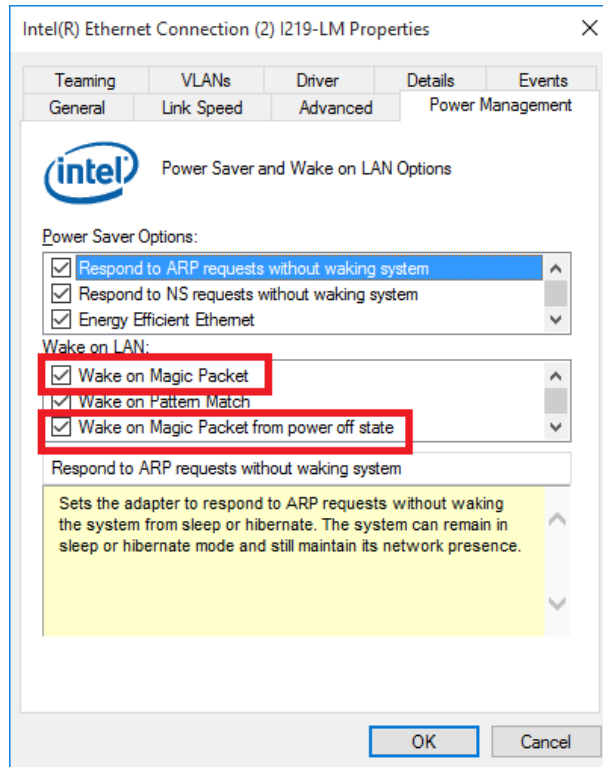

Magic Packet

The magic packet is a broadcast frame containing anywhere within its payload 6 bytes of all 255 (FF FFFFFFFF in hexadecimal), followed by sixteen repetitions of the target

computer's 48-bit MAC address. For example, NIC's 48-bit MAC Address is 78h D0h 04h 0Ah 0Bh 0Ch

```

DESTINATION SOURCE MISC
FF FFFFFFFF
78 D0 04 0A 0B 0C 78 D0 04 0A
0B 0C
78 D0 04 0A 0B 0C 78 D0 04 0A
    
```

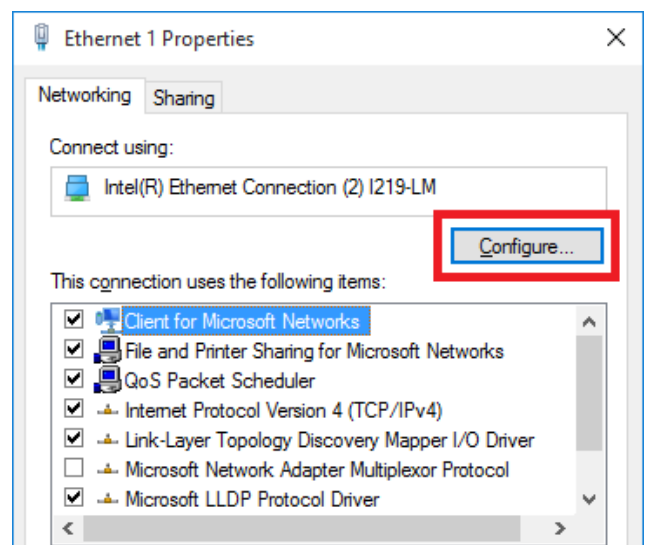

0B 0C

78 D0 04 0A 0B 0C 78 D0 04 0A 0B 0C

78 D0 04 0A 0B 0C 78 D0 04 0A 0B 0C

78 D0 04 0A 0B 0C 78 D0 04 0A 0B 0C

78 D0 04 0A 0B 0C 78 D0 04 0A 0B 0C

78 D0 04 0A 0B 0C 78 D0 04 0A 0B 0C

78 D0 04 0A 0B 0C 78 D0 04 0A 0B 0C

MISC CRC

There are some free tools available on Internet that can be used to send a magic packet.

Please refer to the following link to understand more about [Magic Packet](#).

4 System Configuration

4.1 BIOS Settings

The system is shipped with factory-default BIOS settings meticulously programmed for optimum performance and compatibility. In this section, we'll illustrate some of BIOS settings you may need to modify. Please always make sure you understand the effect of change before you proceed with any modification. If you are unsure of the function you are changing, it is recommended to change one setting at a time to see its effect(s).

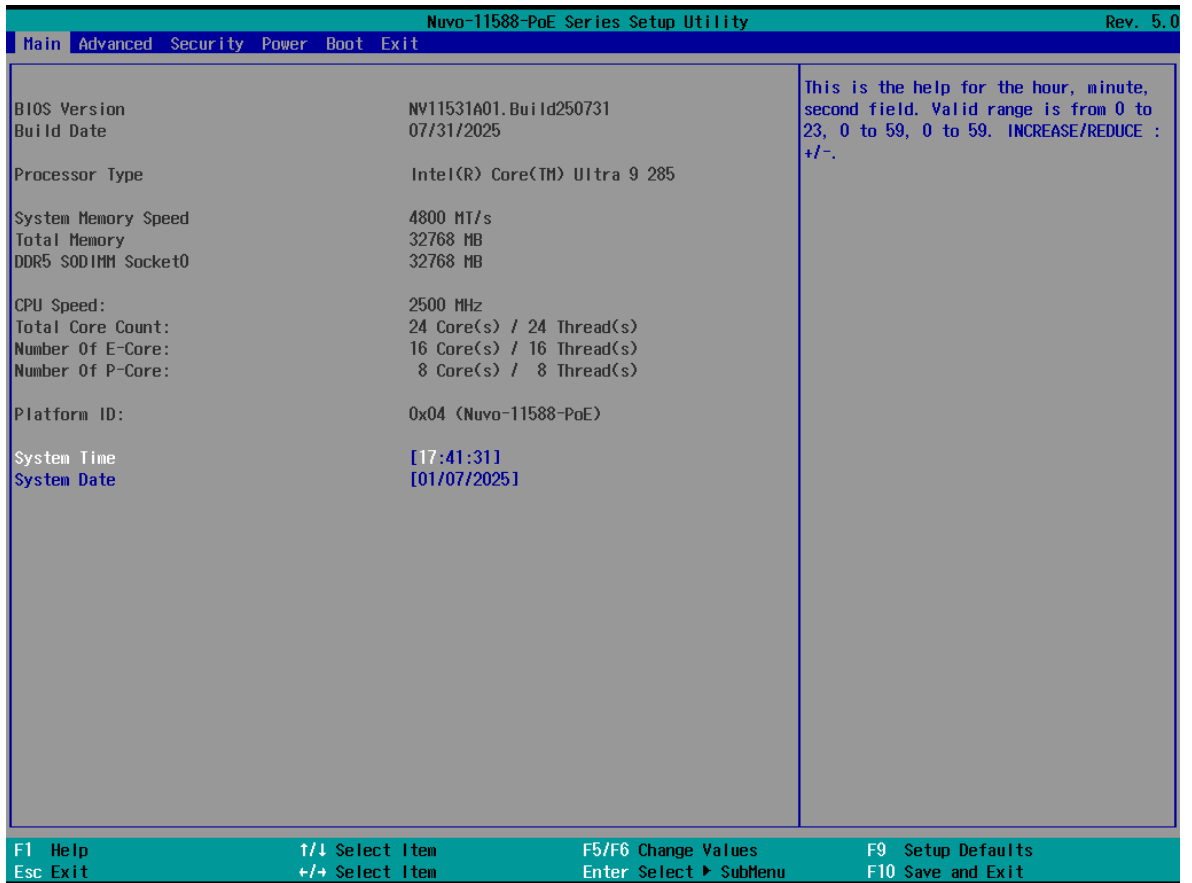

 **NOTE**

Not all BIOS settings will be discussed in this section. If a particular setting/ function you are after requires specific BIOS settings but is not discussed in this section, please contact Neusys Technical Support staff.

4.1.1 COM Port Configuration

The system's [COM1/ COM2](#) ports support RS-232 (full-duplex), RS-422 (full-duplex) and RS-485 (half-duplex) mode. You can set the COM1 operating mode via BIOS settings. Another option in BIOS called “*Slew Rate*” defines how sharp the rising/falling edge is for the output signal of COM1. For long-distance RS-422/485 transmission, you may set the “*Slew Rate*” option as “High” to improve signal quality. For RS-422/485 communication, the “*RS-422/485 Termination*” option determines whether to enable/disable internal termination of RS-422/485 transceiver according to your wiring configuration (e.g. with or without external termination).

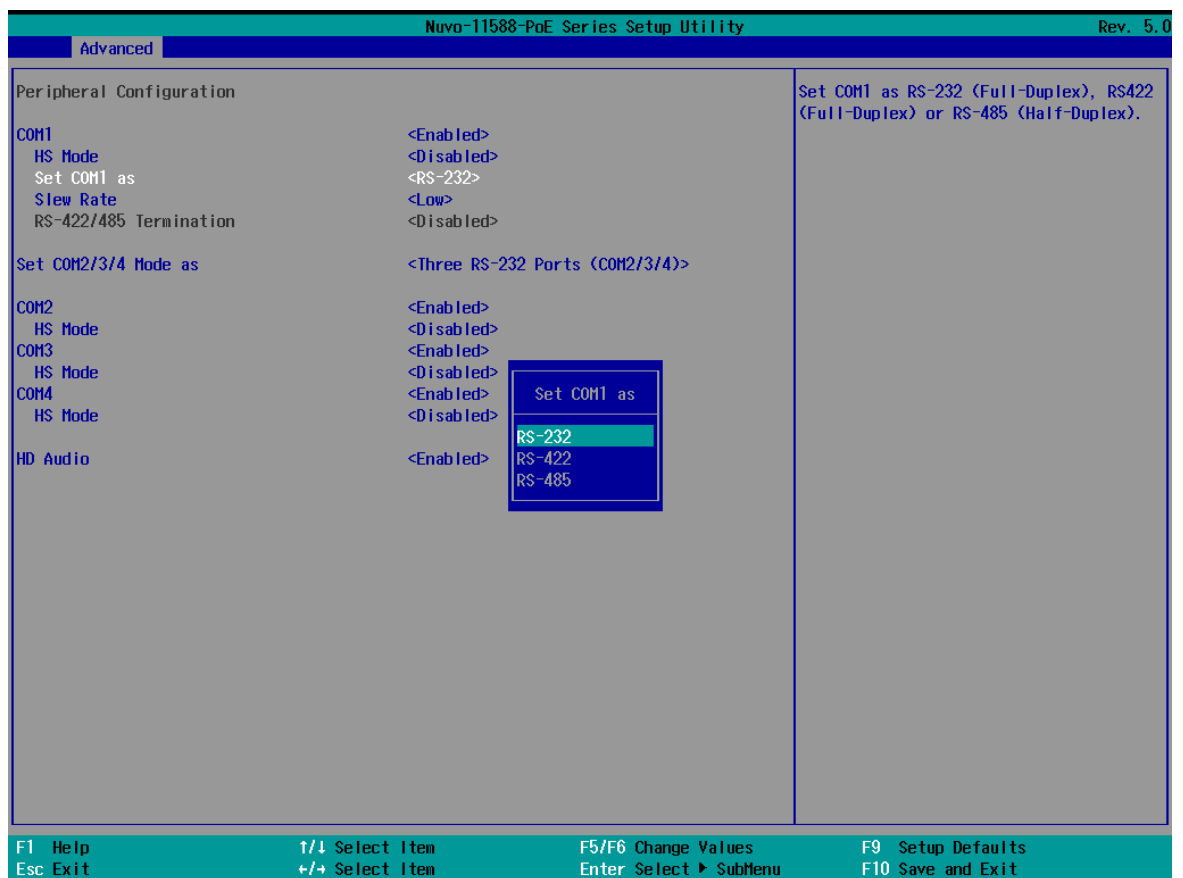

To set COM port operating mode:

1. Press **F2** when the system boots up to enter the BIOS setup utility.
2. Go to **[Advanced] > [Peripheral Configuration]**.
3. Set the **[Set COM1 Mode as]** option to the desired mode.
4. Once set, press **F10** to “Exit Saving Changes”.

4.1.2 COM Port High Speed Mode

The high speed mode of each COM port effectively allows for the port's baud rate generator to operate at 8x the speed with an effective baud rate of 921,600 bps (115,200 x 8). Please refer to the following instructions on how to enable the high speed mode for your COM port (COM1 used as an example).



To set COM port high speed mode:

1. Press **F2** when the system boots up to enter the BIOS setup utility.
2. Go to **[Advanced] > [Peripheral Configuration]**.
3. Enable or set the **[Set COM1 Mode as]** option to the desired mode.
4. Highlight **[HS Mode]** and press ENTER to bring up options, highlight **[Enable]** and press ENTER.
5. Once set, press **F10** to "Exit Saving Changes".

4.1.3 COM2/3/4 Port Configuration

The system's [COM2/ 3/ 4 ports](#) support RS-232 (full-duplex) while COM2 also supports RS-422 (full-duplex) and RS-485 (half-duplex) mode. The operating mode can be configured via the BIOS. Another option in BIOS called “*Slew Rate*” defines how sharp the rising/falling edge is for the output signal. For long-distance RS-422/485 transmission, you may set the “*Slew Rate*” option as “High” to improve signal quality. For RS-422/485 communication, the “*RS-422/485 Termination*” option determines whether to enable/disable internal termination of RS-422/485 transceiver according to your wiring configuration (e.g. with or without external termination).

To set COM2/ 3/ 4 operating mode:

1. Press **F2** when the system boots up to enter the BIOS setup utility.
2. Go to **[Advanced]** → **[Peripheral Configuration]**.
3. Set the **[Set COM2/ 3/ 4 Mode as]** option to the desired mode.
4. Once set, press **F10** to save setting and exit.

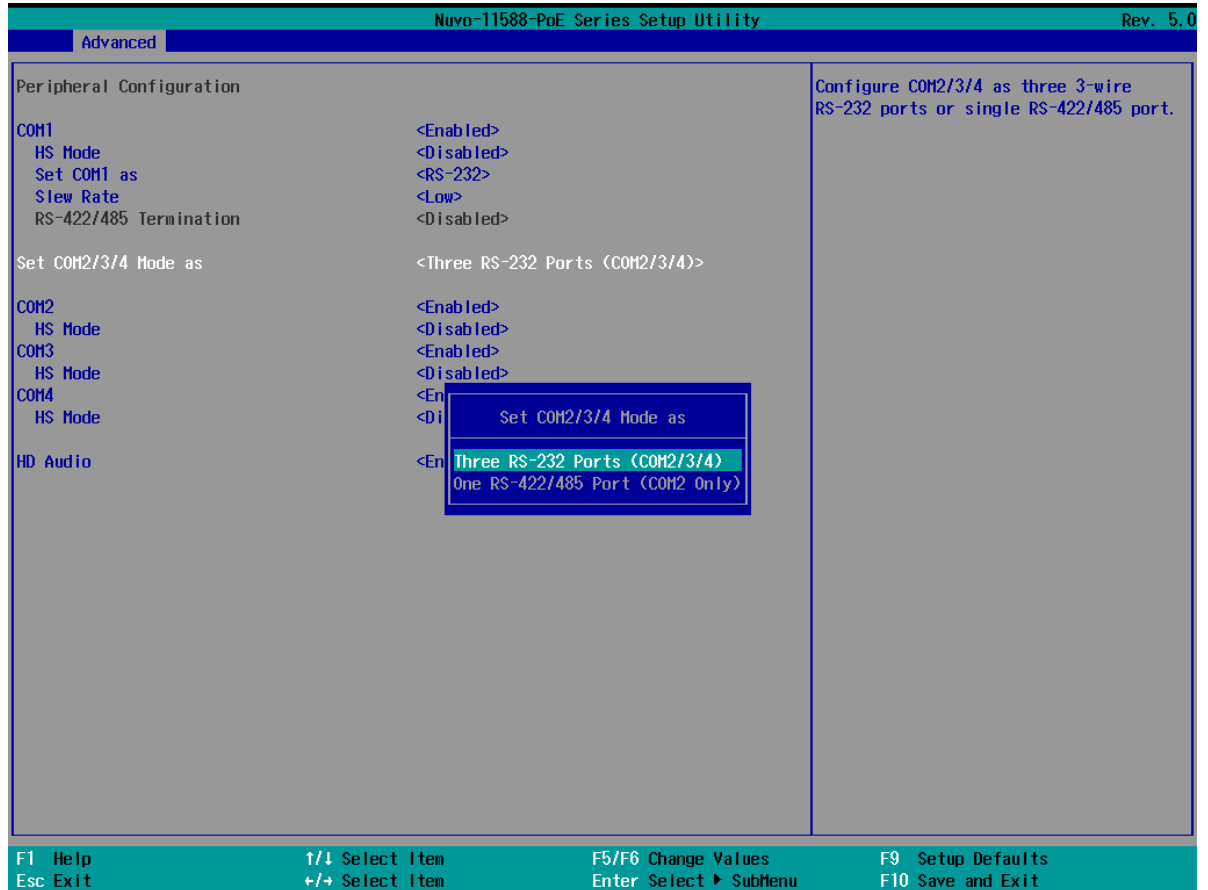

4.1.4 TPM Availability

Trusted Platform Module (TPM) is a hardware-based cryptoprocessor to secure hardware by integrating cryptographic keys into devices. By default, the system is designed with firmware TPM. As TPM requires 64-bit Windows 10 with UEFI boot mode, it is enabled in BIOS by default.

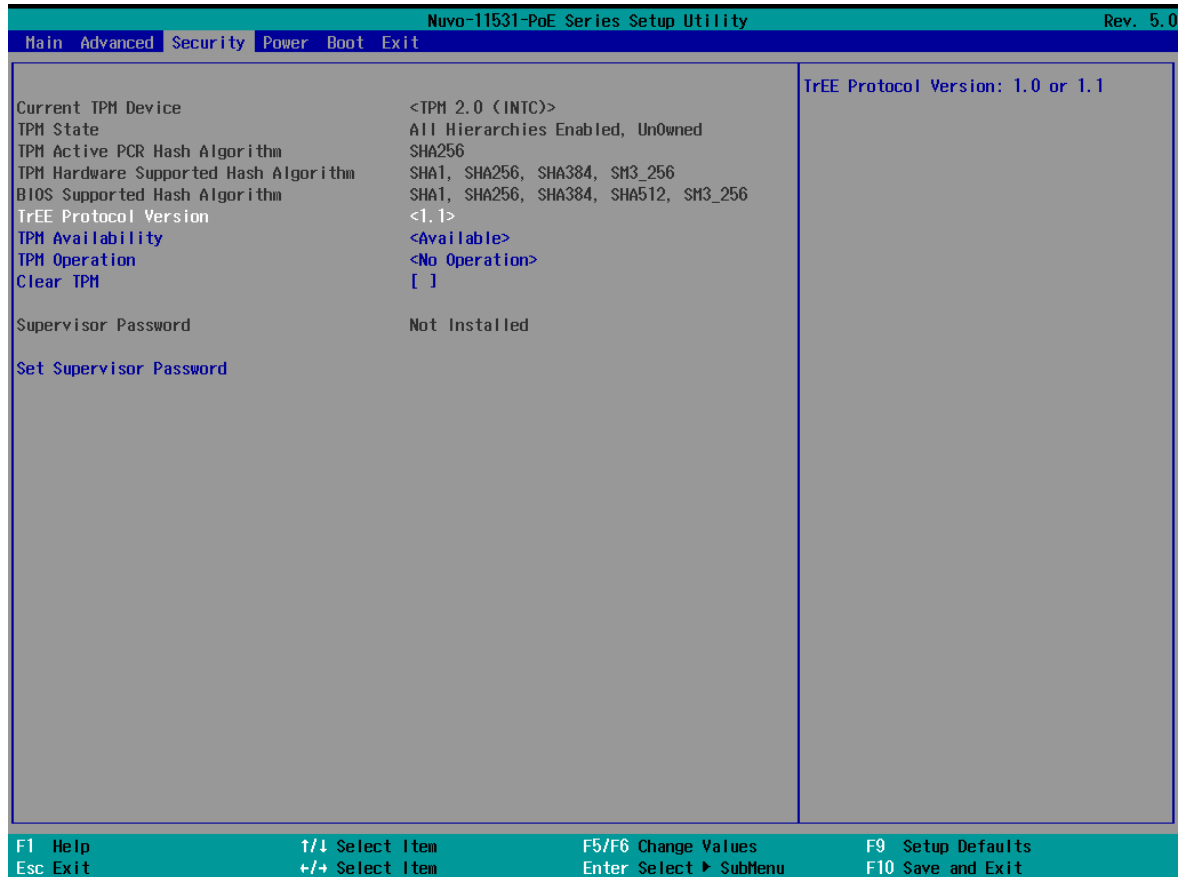

To enable TPM availability:

1. When system boots up, press F2 to enter BIOS setup utility.
2. Go to **[Security] > [TPM Availability]**, press ENTER to bring up Options, Available/Hidden.
3. Highlight your selection, press Enter and press F10 to "Exit Saving Changes".

4.1.5 Power over Ethernet (PoE) Power Enable

Power over Ethernet (PoE) supplies electrical power and data on a standard CAT-5/CAT-6 Ethernet cable. Acting as a PoE PSE (Power Sourcing Equipment), compliant with IEEE 802.3at, each PoE port delivers up to 25W to a Powered Device (PD). The system has a total 100W power budget. The PoE power can be Enabled/ Disabled in the BIOS.

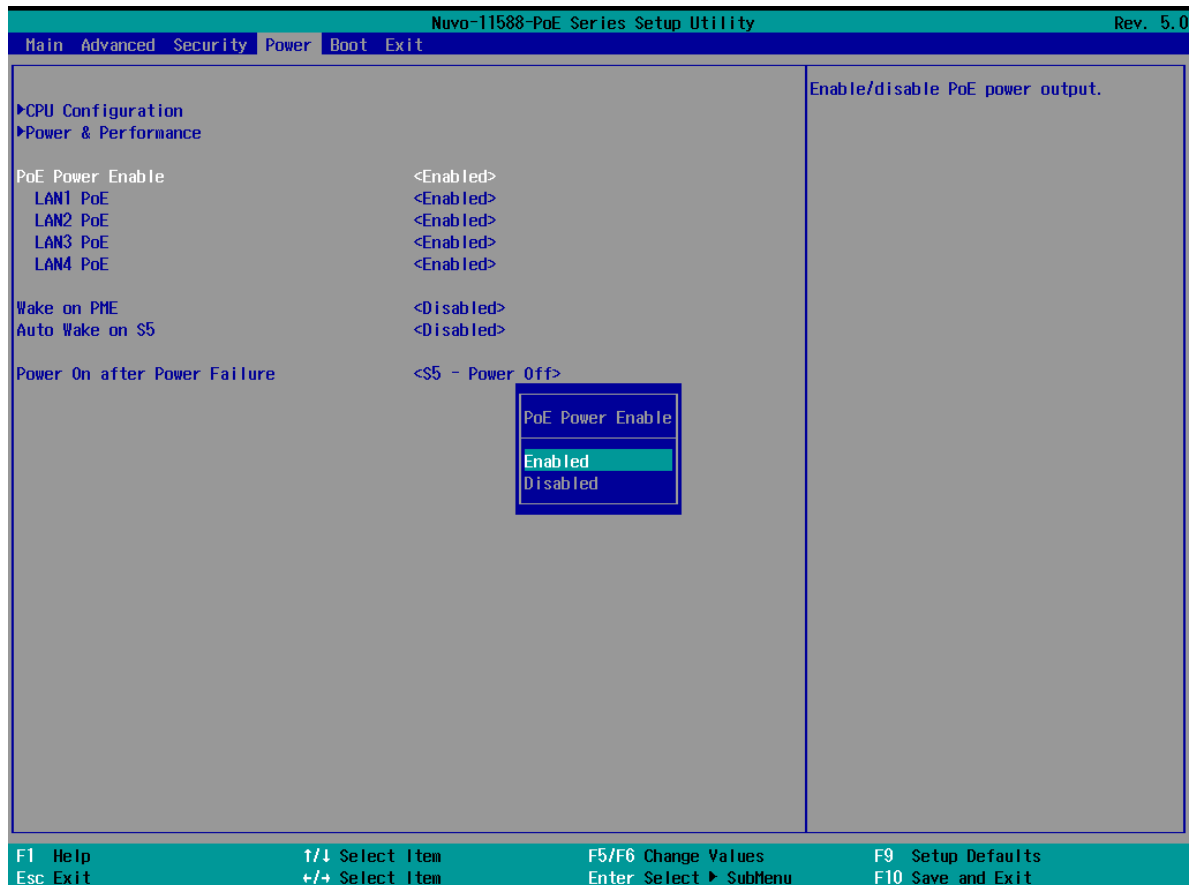

To enable/ disable “PoE Power Enable” option:

1. When system boots up, press F2 to enter BIOS setup utility.
2. Go to **[Power] > [PoE Power Enable]**.
3. Press ENTER to bring up setting options, scroll to the setting (Enabled/ Disabled) you desire and press ENTER to set.

- You can also enable/ disable each port, individually. Simply use the arrow key to highlight the port, press ENTER to bring up options (Enabled/ Disabled), press ENTER again to select the option.

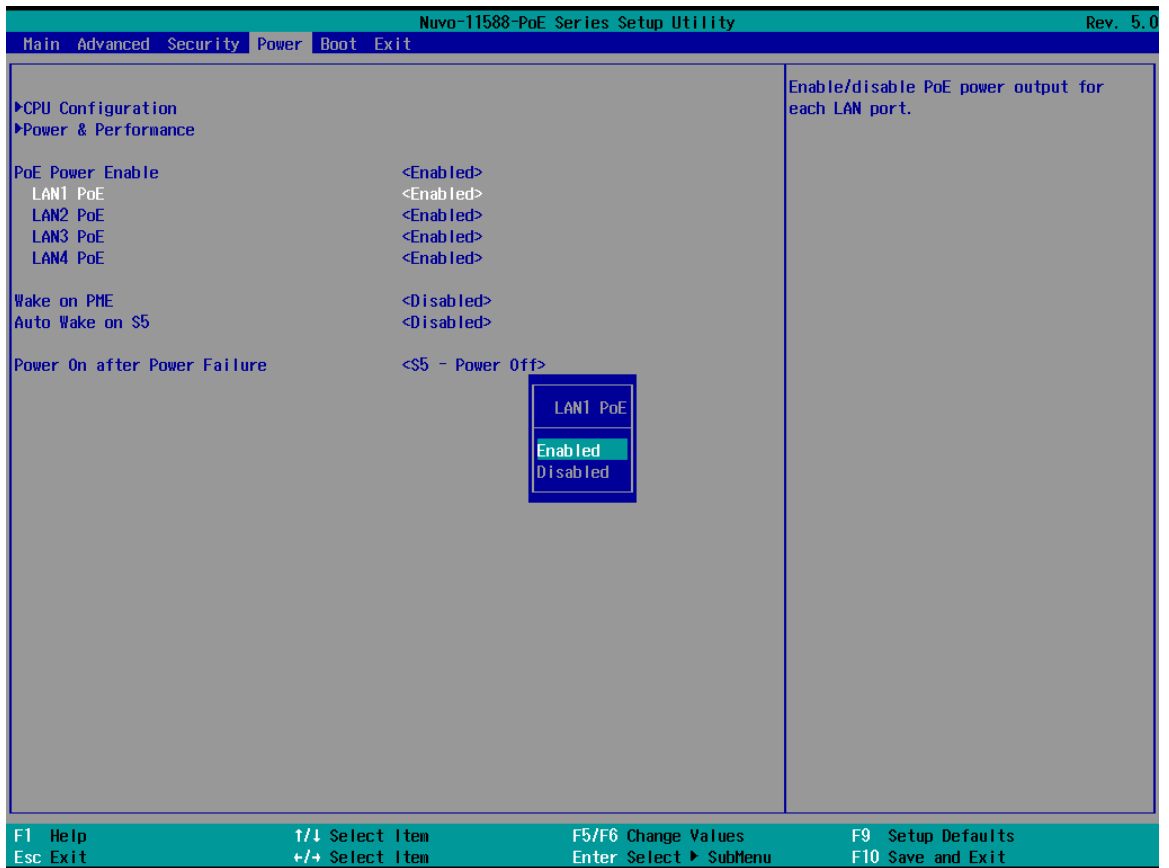
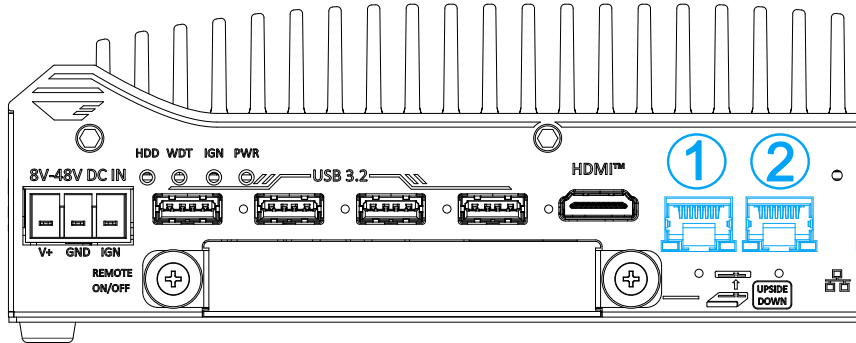

- Press F10 to "Exit Saving Changes".

4.1.6 Auto Wake on S5

When the system is set to operate in S5 state, the user can specify a time to turn on the system, daily or monthly.

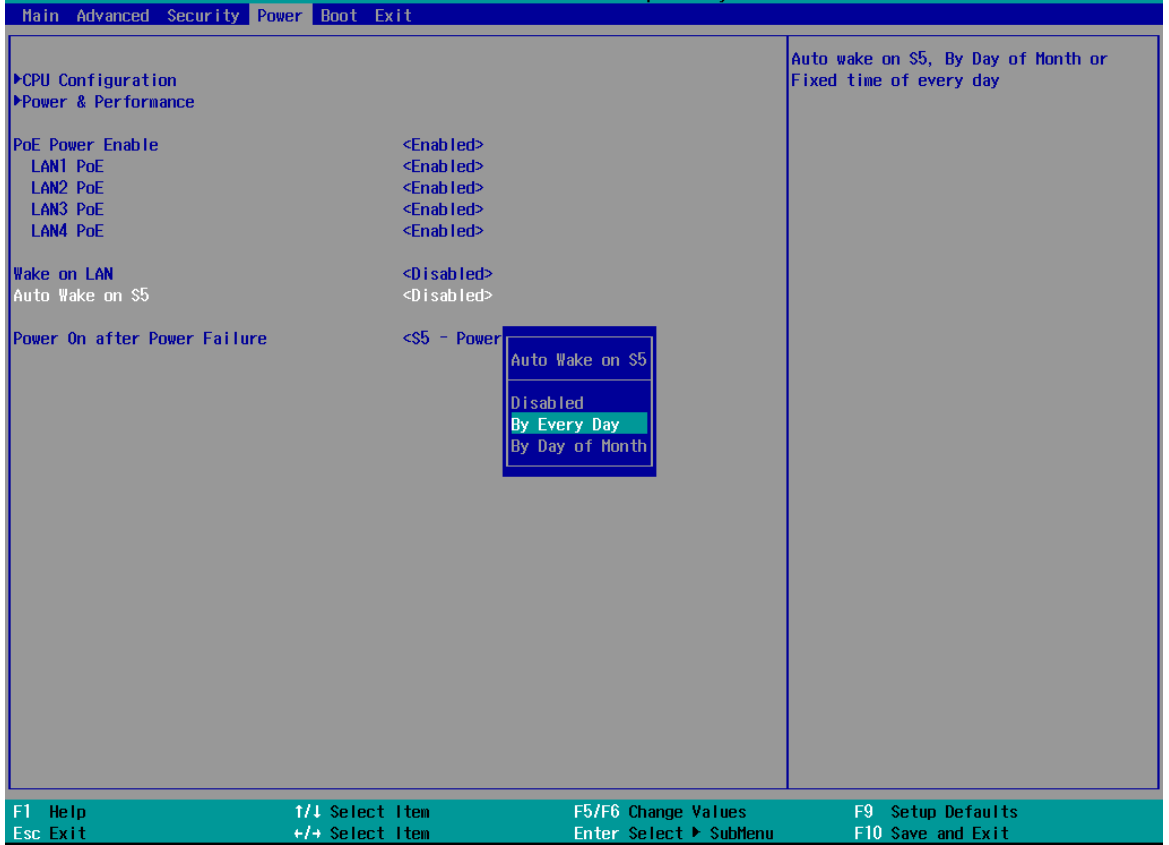

Value	Option	Description
Auto Wake on S5	Disabled	The system does not turn on when operating in state S5.
	By Every Day	The system turns on each day when operating in state S5. Specify the time of day.
	By Day of Month	The system turns on each month when operating in state S5. Specify the day and time.

Highlight your selection, press ENTER and press F10 to “Exit Saving Changes”.

4.1.7 Power On After Power Failure Option

This option defines the behavior of System series when DC power is supplied.

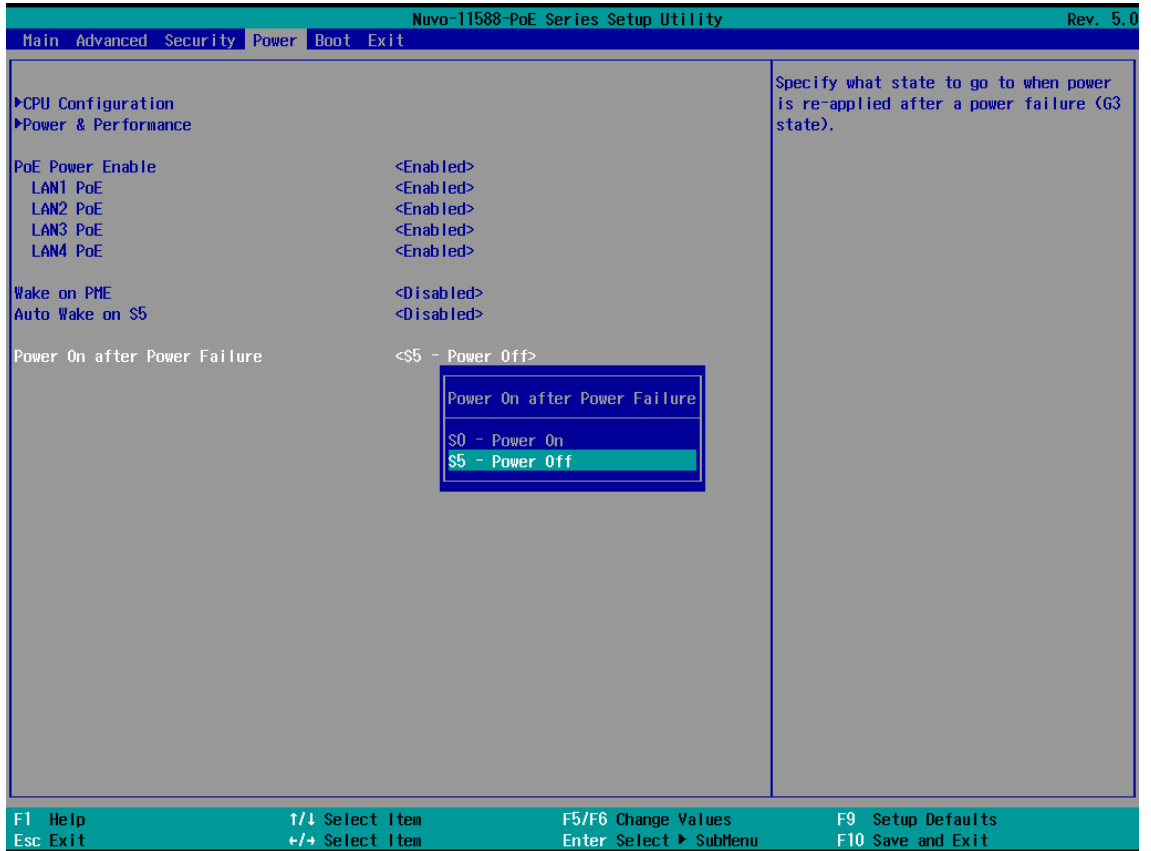

Value	Description
S0 – Power On	System is powered on when DC power is supplied.
S5 – Power Off	System is kept in off state when DC power is supplied.

To set “Power On after Power Failure” option:

1. When system boots up, press F2 to enter BIOS setup utility.
2. Go to **[Power] > [Power On after Power Failure]**.
3. Scroll down to highlight **[Power On after Power Failure]**, press ENTER to bring up setting options, S0 – Power On or S5 – Power Off, and press ENTER to select the setting.
4. Press F10 to “Exit Saving Changes”.

4.1.8 Power & Performance (CPU SKU Power Configuration)

The system supports Intel Core Ultra 200S CPUs from from 35W to 65W TDP. A unique feature, “**SKU Power Config**” is implemented in BIOS to allow users to specific user-defined SKU power limit. Although the system is designed to have best thermal performance with CPUs of 35W TDP, you can install a 65W CPU and limit its SKU power (to 35W) to obtain more computing power. This feature gives you the flexibility of CPU selection and great balance between computing power and operating temperature range.

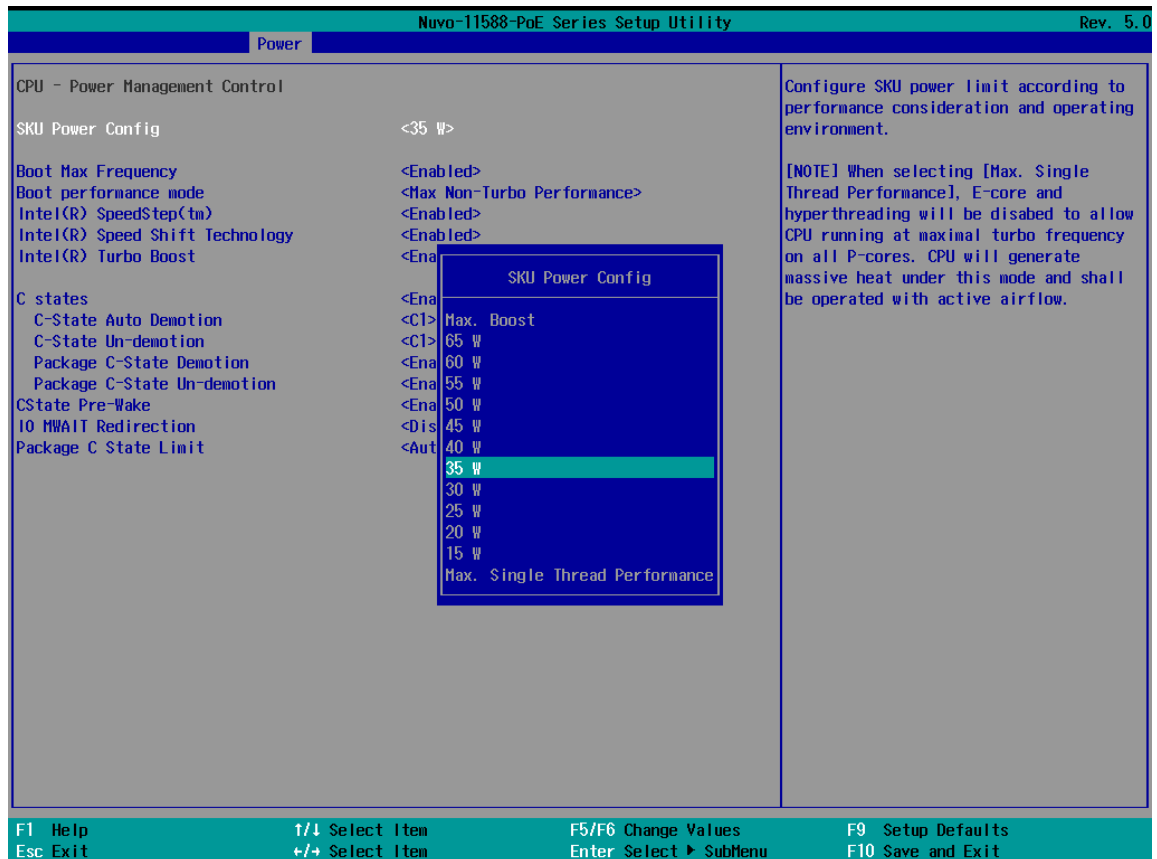

To configure the CPU SKU power limit:

1. When the system boots up, press F2 to enter BIOS setup utility.
2. Go to **[Power]** → **[Power & Performance]**.
3. Select a proper value of SKU power limit for **[SKU Power Config]** option.
4. Press F10 to “Exit Saving Changes.



NOTE

The option "Max. Boost" unleashes the CPU's maximum performance with the highest power consumption. Make sure you're using a power supply with a rated power output four times that of the CPU TDP to ensure reliable system operations.

For users not utilizing multi-thread performance, you may select "Max. Single Thread Performance" option to enable maximum single core performance.

4.1.9 Wake on PME (Wake-On-LAN) Option

Wake on PME (WOL) is a mechanism which allows you to turn on your System series via the Ethernet connection. To utilize Wake on PME function, you have to enable this option first in the BIOS. Please refer "[Powering On Using Wake-on-PME \(Wake-on-LAN\)](#)" to set up the system.



To enable/ disable “Wake on LAN” option:

1. When system boots up, press F2 to enter BIOS setup utility.
2. Go to **[Power] > [Wake on LAN]**.
3. Press ENTER to bring up setting options, scroll to the setting you desire and press Enter to set.
4. Press F10 to “Exit Saving Changes”.

4.1.10 Boot Menu

The Boot menu in BIOS allows you to specify the system’s boot characteristics by setting bootable device components (boot media) and method. Or, you may press F12 upon system start up and select a device you wish boot from.

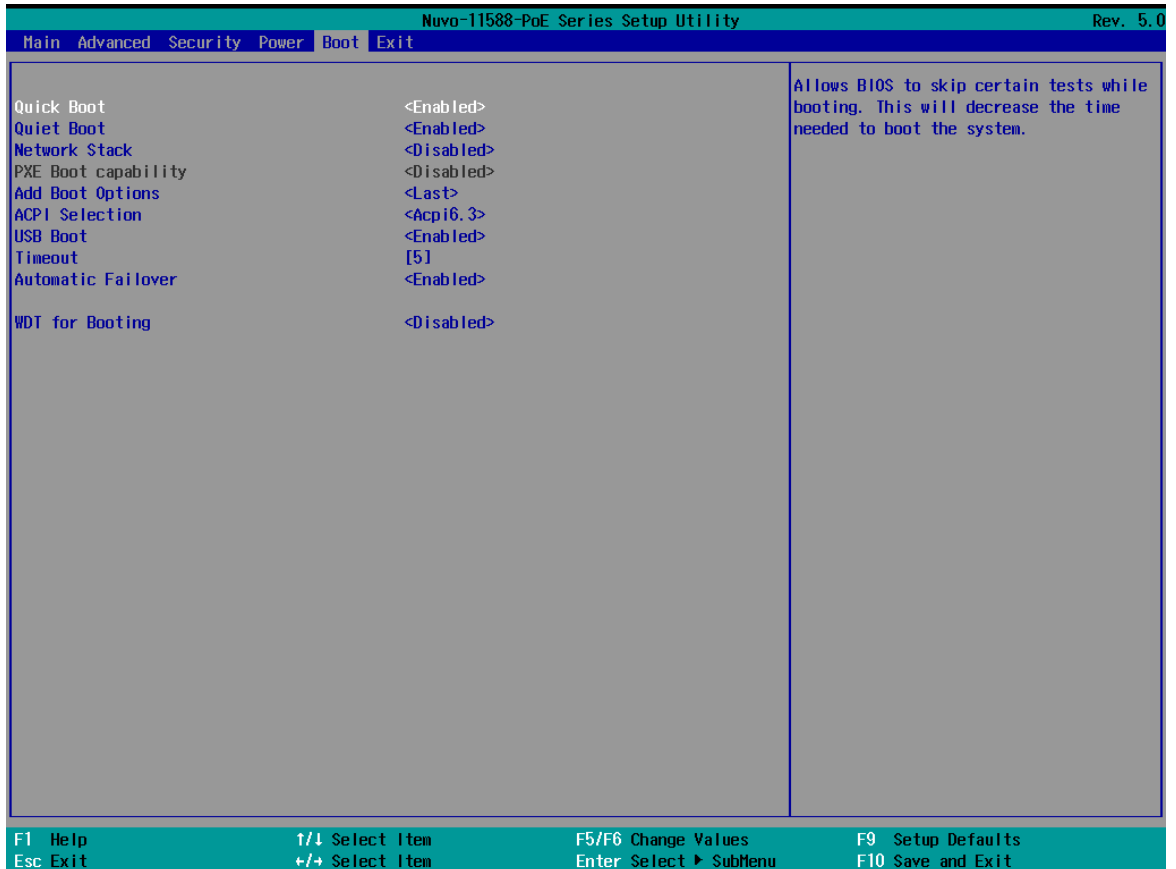

Value	Option	Description
Boot Type	UEFI Boot Type	Only UEFI boot media listed are approved as boot media.
Quick Boot	Enabled	The system starts up faster because BIOS skips various hardware function tests
	Disabled	The system starts up slower because BIOS goes through various hardware functions tests
Network Stack	Enabled	The system is available for network access using UEFI.
	Disabled	The system is not available for network access using UEFI.
PXE Boot capability	Disabled	Only UEFI Network Stack is supported: Preboot eXecution Environment (PXE) is not supported
	Enabled	By enabling the PXE boot, one can choose to

		boot via I219 Only/ I225 Only or All NICs .
Add Boot Options	First	Newly detected boot media are placed at the top of the boot order.
	Last	Newly detected boot media are placed at the bottom of the boot order.
ACPI Selection	1.0B/ 3.0/ 4.0/ 5.0/ 6.0	Advanced Configuration and Power Interface allows the operating system to control system power management
USB Boot	Enabled	Allow boot from bootable USB devices.
	Disabled	Does not allow boot from bootable USB devices
Timeout	1, 2, 3, etc (in seconds)	Boot delay time in seconds to give the user time to activate the hotkey to access the BIOS
Automatic Failover	Enabled	Automatically checks for the next bootable device when the set default device fails.
	Disabled	Will only boot from the designated device.
WDT for booting	Disabled, 1, 3, 5, 10 (minutes)	WDT ensures a successful system boot by specifying a timeout value

4.1.11 Add Boot Options (Position New Boot Device)

The “Add Boot Options” allow you to determine whether a newly added device (eg. USB flash disk) is to boot as the first device to boot or the last in the boot sequence.

To set the newly-installed boot device as the first or last boot device:

1. Press **F2** when the system boots up to enter the BIOS setup utility.
2. Go to **[Boot] > [Add Boot Options]** menu.
3. Select **[First]** or **[Last]** for your newly-added boot device and press ENTER.

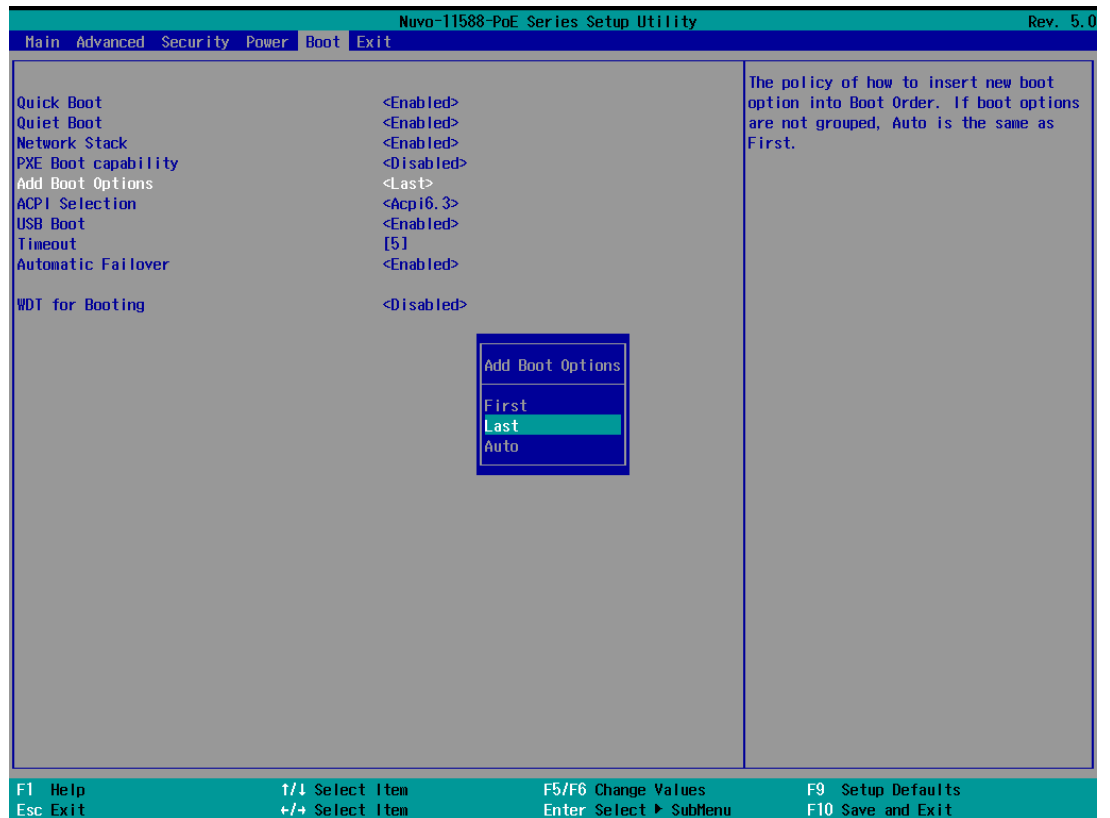

4. Once set, press **F10** to “Exit Saving Changes”.

4.1.12 Watchdog Timer for Booting

The watchdog timer secures the boot process by means of a timer. Once the timer expires, a reset command is issued to initiate another booting process. There are two options in BIOS menu, “*Automatically after POST*” and “*Manually after Entering OS*”. When “*Automatically after POST*” is selected, the BIOS automatically stops the watchdog timer after POST (Power-On Self Test) OK. When “*Manually after Entering OS*” is selected, the user must stop the watchdog timer once booted into the OS. This guarantees the system can always boot into the OS, otherwise another booting process will be initiated. For information about programming watchdog timer, please refer to [Watchdog Timer & Isolated DIO](#).

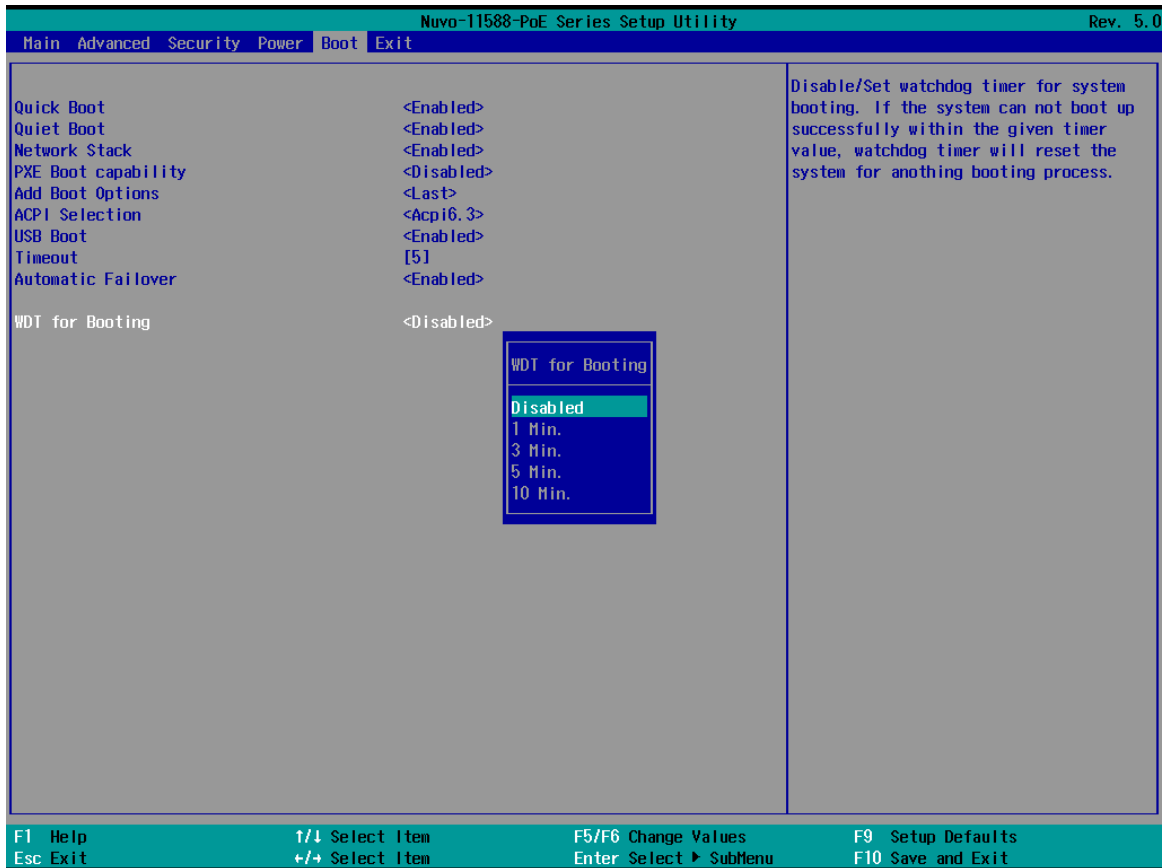

To set the watchdog timer for boot in BIOS:

1. When system boots up, press F2 to enter BIOS setup utility.
2. Go to **[Boot]** menu.
3. Disable or select timeout value for **[WDT for Booting]** option.
4. Once you give a timeout value, the **[WDT Stop Option]** option appears. You can select “*Automatically after POST*” or “*Manually after Entering OS*”.
5. Press F10 to “Exit Saving Changes”.

5 OS Support and Driver Installation

5.1 Operating System Compatibility

The system supports most operating system developed for Intel® x86 architecture. The following have been tested and verified by Neosys Technology:

Windows 11 24H2

Ubuntu 24.04.1 LTS



NOTE

** For Linux system, user may need to manually compile and install the driver for Intel graphics or I225/ I226 GbE controller if the driver is not embedded in kernel. You can visit Intel website for further information.*

*** For distributions, graphics driver and RAID function may not be completely implemented in its kernel. You may encounter restrictions when using these features, such as triple independent display and RAID. For optimum operation, it is the users' responsibility to manually check for new drivers and upgrades!*

Neosys may remove or update operating system compatibility without prior notice. Please contact us if your operating system of choice is not on the list.

5.2 System Driver Installation

The system drivers are available online, please click on this [link](#) to download the drivers.

5.3 Driver Installation for Watchdog Timer Control

Neosys provides a driver package which contain function APIs for Watchdog Timer control function. You should install the driver package (WDT_DIO_Setup.exe) in prior to use these functions. Please note that you must install WDT_DIO_Setup_v2.4.1.0 or later versions.

Please refer to this [link](#) to download WDT_DIO.

Appendix A Using WDT & DIO

The watchdog timer (WDT) function to ensure reliable system operation. The WDT is a hardware mechanism to reset the system if the watchdog timer is expired. Users can start the WDT and keeping resetting the timer to make sure the system or program is running. Otherwise, the system shall be reset.

In this section, we'll illustrate how to use the function library provided by Neosys to program the WDT functions. Currently, WDT driver library supports Windows 10 x64 and WOW64 platform. For other OS support, please contact Neosys Technology for further information.

Installing WDT_DIO Library

The WDT_DIO function library is delivered in the form of a setup package named **WDT_DIO_Setup.exe**. In prior to program WDT, you should execute the setup program and install the WDT library. Please use the following WDT_DIO_Setup packages according to your operating systems and application.

- For Windows 10 64-bit OS with 64-bit application (x64 mode), please install WDT_DIO_Setup_v2.4.1.0(x64).exe or later versions.

WDT and DIO Library Installation

To setup WDT & DIO Library, please follow instructions below.

1. Execute **WDT_DIO_Setup.2.4.1.0.exe** (or later) and the following dialog may appear. If so, click on “More Info”.



2. Click on “Run anyway” for installation, and click on “Yes” to proceed.

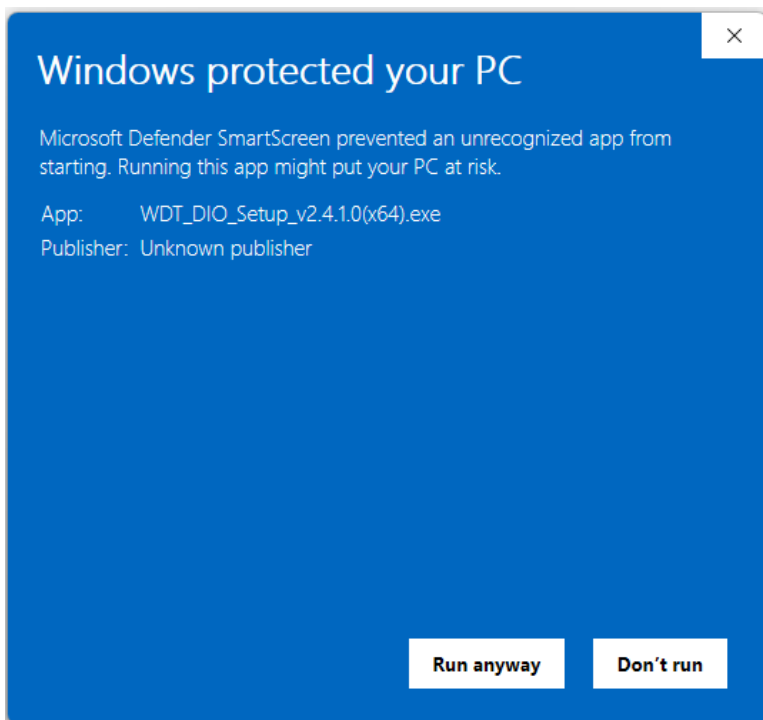

3. Click on Next to begin installation.

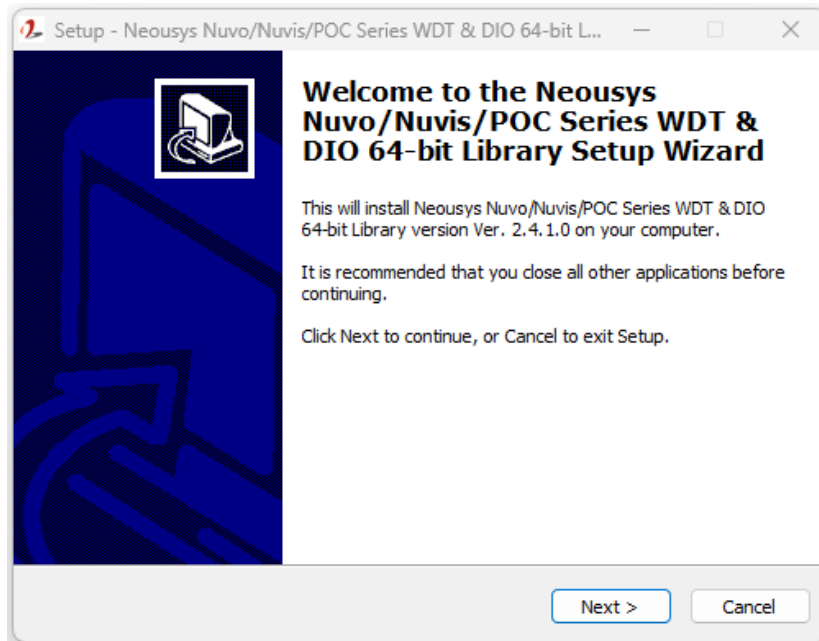

4. Specify the directory you would like to install to, and Click "Next >". The default directory is *C:\Neosys\WDT_DIO(x64)*.

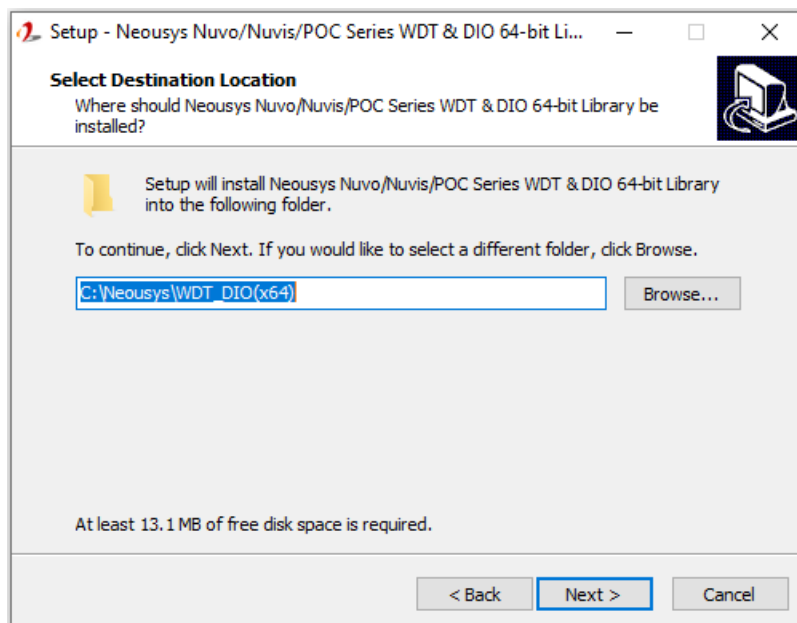

- Once the installation has finished, a dialog will appear to prompt you to reboot the system. The WDT & DIO library will take effect after the system has rebooted.

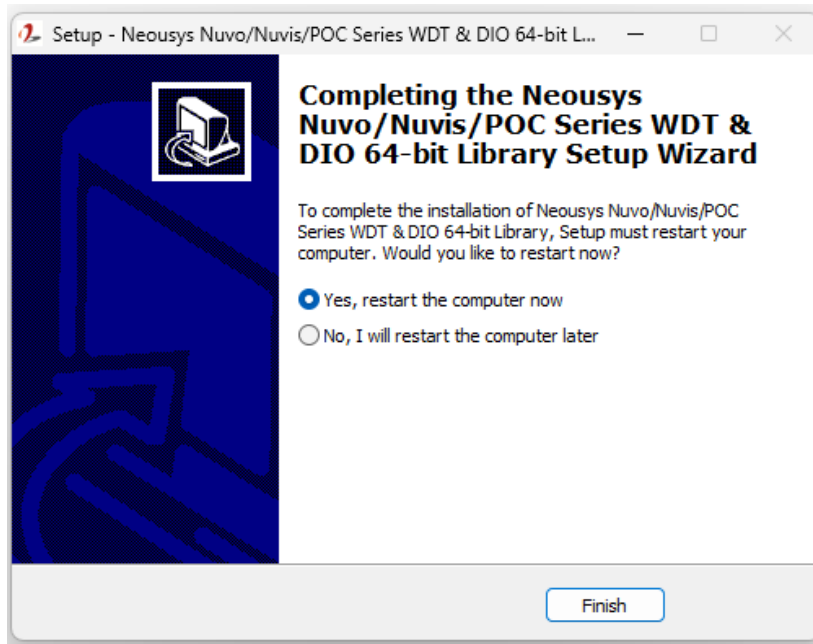

- When programming your WDT or DIO program, the related files are located in

Header File:	\Include
Library File:	\Lib
Function	\Manual
Reference:	
Sample Code:	\Sample\WDT_Demo (Demo for Watchdog Timer)

WDT Functions

InitWDT

Syntax	BOOL InitWDT(void);
Description:	Initialize the WDT function. You should always invoke InitWDT() before set or start watchdog timer.
Parameter	None
Return Value	TRUE: Successfully initialized FALSE: Failed to initialize
Usage	BOOL bRet = InitWDT()

SetWDT

Syntax	BOOL SetWDT(WORD tick, BYTE unit);
Description	Set timeout value and unit for watchdog timer. When InitWDT() is invoked, a default timeout value of 255 seconds is assigned.
Parameter	<i>tick</i> WORD value (1 ~ 65535) to indicate timeout ticks. <i>unit</i> BYTE value (0 or 1) to indicate unit of timeout ticks. 0 : unit is minute 1 : unit is second
Return Value	If value of unit is correct (0 or 1), this function returns TRUE, otherwise FALSE.
Usage	WORD tick=255; BYTE unit=1; //unit is second. BOOL bRet = SetWDT(tick, unit); //timeout value is 255 seconds

StartWDT

Syntax	BOOL StartWDT(void);
Description	Starts WDT countdown. Once started, the WDT LED indicator will begin blinking. If ResetWDT() or StopWDT is not invoked before WDT countdowns to 0, the WDT expires and the system resets.
Parameter	None
Return Value	If the timeout value is given in correct format (WDT started), this function returns TRUE, otherwise FALSE
Usage	BOOL bRet = StartWDT()

ResetWDT

Syntax	BOOL ResetWDT(void);
Description	Reset the timeout value to the value given by SetWDT().If ResetWDT() or StopWDT is not invoked before WDT countdowns to 0, the WDT expires and the system resets.
Parameter	None
Return Value	Always returns TRUE
Usage	BOOL bRet = ResetWDT()

StopWDT

Syntax	BOOL StopWDT(void);
Description	Stops the countdown of WDT. When WDT has stopped, the WDT LED indicator stops blinking.
Parameter	None
Return Value	Always returns TRUE
Usage	BOOL bRet = StopWDT()

Appendix B PoE On/ Off Control

The system offers 802.3at PoE+ ports and users are allowed to manually turn on or off the power supply of each PoE port. This can be useful in power device (PD) fault-recovery or power reset. The APIs are part of Neosys WDT_DIO driver package. Please follow the instructions in [Appendix A Watchdog Timer & Isolated DIO](#) for installation before programming PoE on/off control function.

GetStatusPoEPort

Syntax	BYTE GetStatusPoEPort (Byte port);
Description	Get current on/off status of designated PoE port.
Parameter	<i>port</i> BYTE value specifies the index of PoE port. Please refer to the following illustration, <i>port</i> should be a value of 1 ~ 4
Return Value	BYTE value indicating PoE on/off status 0 if port is disabled (off) 1 if port is enabled (on)
Usage	BYTE bEnabled = GetStatusPoEPort (1); //Get on/off status of PoE Port#1

 **NOTE**
Please note that Power over Ethernet ports numbering are 4, 3, 2, 1, from left to right.

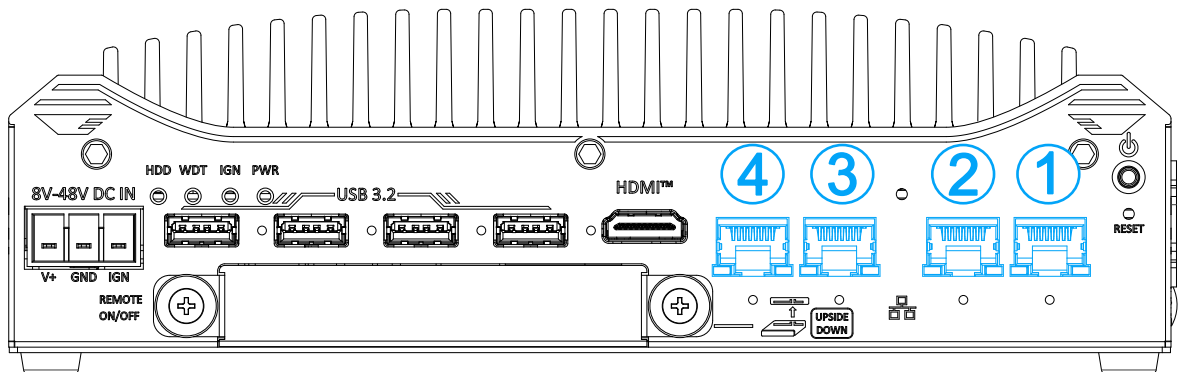

EnablePoEPort

Syntax	BOOL EnablePoEPort (BYTE port);
Description	Turn on PoE power of designated PoE port.
Parameter	<i>port</i> BYTE value specifies the index of PoE port. Please refer to the following illustration, <i>port</i> should be a value of 1 ~ 4
Return Value	TRUE if enabled success FALSE if fail to enable.
Usage	BOOL bRet = EnablePoEPort (1); //Turn on PoE Port#1

 **NOTE**

Please note that Power over Ethernet ports numbering are 4, 3, 2, 1, from left to right.

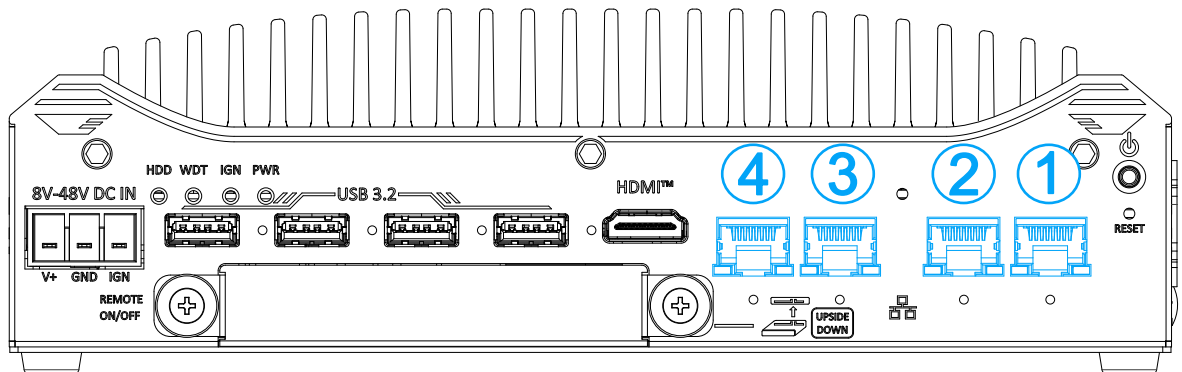

DisablePoEPort

Syntax	BOOL DisablePoEPort (BYTE port);
Description	Turn off PoE power of designated PoE port
Parameter	<i>port</i> BYTE value specifies the index of PoE port. Please refer to the following illustration, <i>port</i> should be a value of 1 ~ 4
Return Value	TRUE if disabled success FALSE if fail to disable
Usage	BOOL bRet = DisablePoEPort (1); //Turn off PoE Port#1



NOTE

Please note that Power over Ethernet ports numbering are 4, 3, 2, 1, from left to right.

