



CTH01

Smart Power Monitor Hub

User Guide

Contents

Chapter 1. Preface.....	4
Chapter 2. Product Introduction.....	6
Overview.....	6
Packing List.....	7
Hardware Introduction.....	8
Chapter 3. Hardware Installation.....	10
Wire Diagrams.....	10
Install the Device.....	11
Chapter 4. ToolBox App Configuration.....	23
Access the Device Using Bluetooth.....	23
Synchronize Device Time.....	25
Configure LoRaWAN [®] Parameters.....	26
Configure the Device Parameters.....	31
Change the Device Password.....	31
Configure General Parameters.....	32
Configure Interface Parameters.....	35
Configure Calibration Parameters.....	37
Configure Threshold Parameters.....	39
Configure Report Parameters.....	41
Configure Data Storage & Retransmission.....	45
Maintain the Device.....	48
Upgrade the Device.....	48
Configure a Template for Configuration Backup.....	49
Reset the Device.....	51
Chapter 5. Uplink Packets and Downlink Commands.....	54
Uplink Packets.....	54
Basic Information Packet.....	54

Periodic Data Packet.....	55
Alarm Report.....	62
Historical Periodic Data.....	66
Downlink Commands.....	68
Commands for General Settings.....	69
Commands for Time Settings.....	71
Commands for Calibration Settings.....	72
Command for Threshold Settings.....	73
Command for Report Parameters.....	76
Commands for Configuration Query.....	78
Commands for Historical Data Query.....	79
Chapter 6. Services.....	84

Chapter 1. Preface

Copyright Statement

This guide may not be reproduced in any form or by any means to create any derivative such as translation, transformation, or adaptation without the prior written permission of Xiamen Milesight IoT Co., Ltd (Hereinafter referred to as Milesight).

Milesight reserves the right to change this guide and the specifications without prior notice. The latest specifications and user documentation for all Milesight products are available on our official website <http://www.milesight.com>

Safety Instruction

These instructions are intended to ensure that users can use the product correctly to avoid danger or property loss. Milesight will not take responsibility for any loss or damage resulting from failure to follow the instructions in this operating guide.

**Warning:**

Serious injury or death may be caused if any of these warnings is neglected.

- The installation and maintenance must be conducted by a qualified service person and should strictly comply with the electrical safety regulations of the local region.
- Ensure the breaker is powered out during the installation.
- To avoid risk of fire and electric shock, do keep the product away from rain and moisture before installed.

**CAUTION:**

Injury or equipment damage may be caused if any of these cautions are neglected.

- The device is intended only for indoor use.
- The device is not intended to be used as a reference sensor, and Milesight will not take responsibility for any damage which may result from inaccurate readings.
- The device must not be disassembled or remodeled in any way.
- Do not place the device close to objects with naked flames.
- Do not place the device where the temperature is below/above the operating range.
- The device must never be subjected to shocks or impacts.



- To protect the security of the device, please change the device password when first configuring.
- To prevent heat accumulation, do not block air circulation around the device.

Revision History

Release Date	Version	Revision Content
Mar. 20, 2026	V1.0	Initial version

Chapter 2. Product Introduction

This chapter describes basic product information.

Overview

The CTH01 Smart Power Monitor Hub is a high-performance, multi-channel device designed for the collection and analysis of electrical parameters. Supporting simultaneous acquisition of 12 current channels and 3 voltage channels, coupled with high-precision computation, the CTH01 delivers a comprehensive set of electrical parameters including power, energy, power factor, harmonic distortion, and voltage three-phase unbalance.

Featuring LoRaWAN[®] wireless communication and Bluetooth for local configuration, CTH01 integrates seamlessly into energy management systems, providing reliable data to support energy savings, preventative maintenance, and cost allocation.

CTH01 is engineered for commercial buildings, industrial plants, data centers, and multi-tenant apartments to enable precise energy consumption measurement, power quality monitoring, and equipment operational analysis for critical circuits within electrical distribution systems.

The device has the following features:

- Comprehensive & Accurate Monitoring
 - Provides high-precision measurement of active, reactive, and apparent power and energy, integrated with power quality analysis functions such as Voltage/Current THD and voltage three-phase unbalance.
 - Compliant with IEC 62053-21/23 standards to ensure professional measurement.
 - Support external wire temperature sensor for cable temperature measurement.

- Flexible Configuration & Deployment
 - 12 current channels can be independently configured for single-phase use, grouped into 4 three-phase circuits or mixed usage.
 - Supports mixed use of split-core Current Transformers (100A/300A/500A/1000A) and 4000A Rogowski coils (coils must be consistent within a group).
 - Provides convenient voltage measurement through direct connection via voltage measurement terminals or an optional non-invasive magnetic attachment, enabling flexible installation.
 - Complete parameter setup, data reading, and current direction calibration can be performed remotely via the Bluetooth-connected Toolbox APP, eliminating the need for physical access.

- Industrial-Grade Reliability & Storage
 - 6-8kHz sampling frequency ensures data measuring accuracy.
 - Stores periodic data records, event logs, and up to 12 months of monthly maximum/minimum values and energy totals.
 - Supports user-defined threshold alarms and device-initiated overload/out-of-range alarms.
- Powerful Expansion & Integration
 - Built-in LoRaWAN[®] protocol for seamless integration with Milesight Development Platform and third-party platforms.
 - Supports Firmware-Update-Over-The-Air (FUOTA) updates for feature enhancements.

Packing List

This section describes the packing list. After unboxing, please check that the following items are included in the package. If any of the below items are missing or damaged, please contact your sales representative.

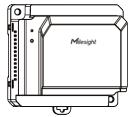

1 × CTH01 Device



1 × Power Adapter



1 × Power Terminal Wire



1 × Power Terminal Block



2 × Mounting Screw Kits

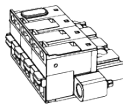

1 × Voltage Terminal Block

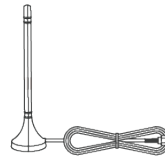

1 × LoRaWAN[®] Magnetic Antenna

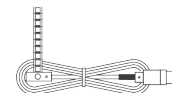

1 × USB-C NTC Sensor

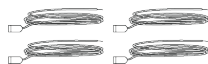

4 × Magnetic Voltage Measuring Cables

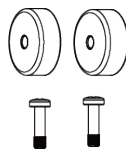

2 × Magnetic Nuts (Optional)



1 × Warranty Card



1 × Quick Guide

Measurement Accessories (Optional Ranges):

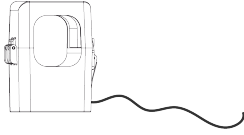

Split-core CT



Rogowski Coils

Hardware Introduction

Hardware Overview

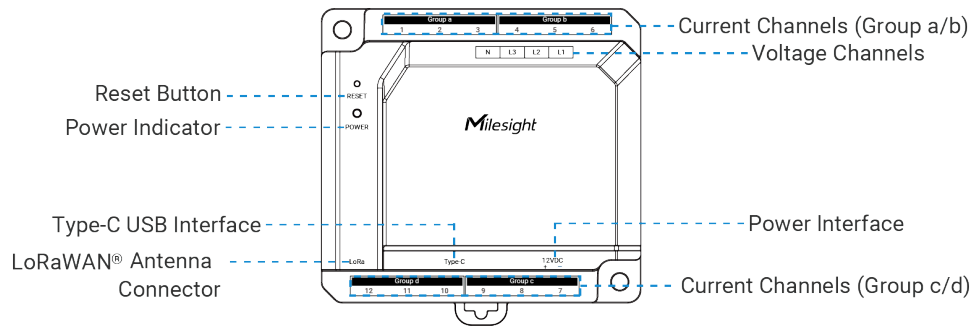

Part	Description
Reset Button	Controls device reset.
Power Indicator	Indicates the device status. For more details, see Power Indicator Description .
Type-C USB Interface	Used for connecting USB-C NTC Sensor to monitor the wire temperature.
LoRaWAN® Antenna Connector	Used for connecting external antenna.
Current Channels (Group a/b/c/d)	Interface for connecting current transformers to collect current.
Voltage Channels	Interface for collecting voltage.
Power Interface	Used for connecting power terminal block to power on the device.

Power Indicator Descriptions

Function	Operation	Indicator
Power On	The power is switched on.	On
Power Off	The power is switched off.	Off

Function	Operation	Indicator
LoRaWAN [®] Status	De-activated	Red Light Stays On
	Sending Join Request	Red Light Blinks Quickly Once
	Activated Successfully	Red Light Blinks Slowly Once
Normal Operation	/	Green Light Stays On
Threshold Alarm	The collected parameters exceeded the set threshold	Red Light Blinks Quickly
Reset to Factory Default	Press and hold the reset button for more than 10s.	Quickly Blinks

Dimensions

The following figure shows the device dimensions (unit: mm).

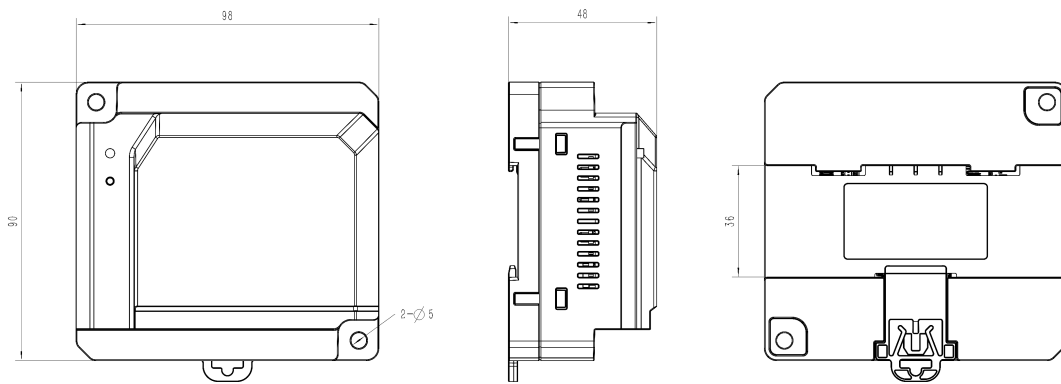

Chapter 3. Hardware Installation

This section describes how to install the accessories and device.

Wire Diagrams

Warning:
Hazardous Voltage Will cause death or serious injury.

Turn off and lock out all power supplying this device before working on this device.

Please read this section carefully before installation and choose the correct wiring method for your power system.

• Three-Phase Four-Wire

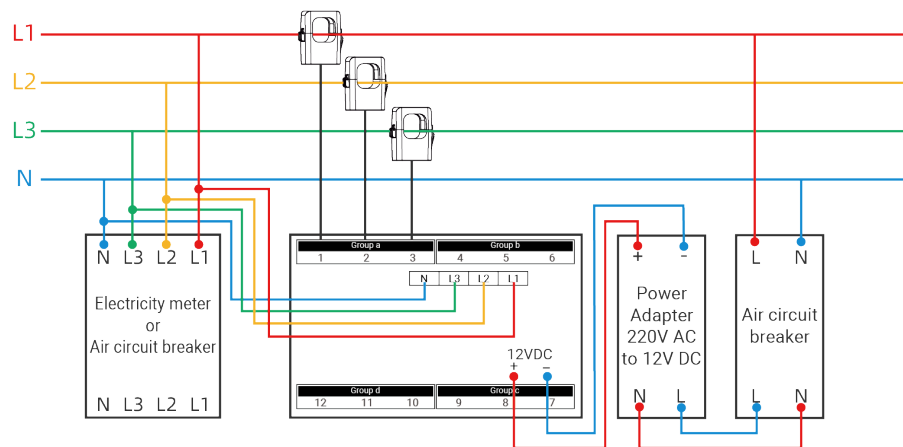

• Three-Phase Three-Wire

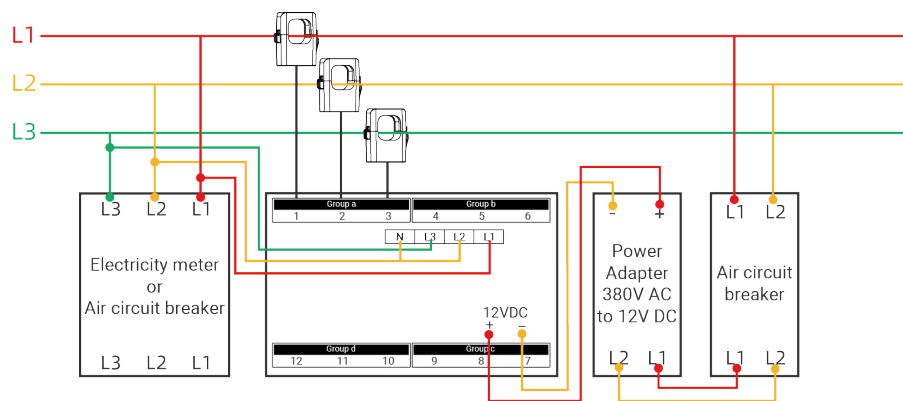

- Single-Phase Two-Wire (L-N)

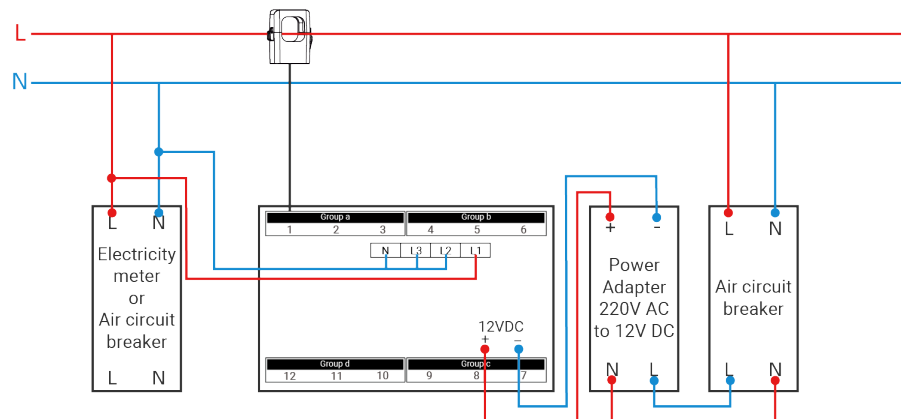

Install the Device

This section describes the hardware installation and wiring procedures for the CTH01, including mounting the device, power supply connection, voltage input connection, connection of grouped current transformers. You can also refer to the [installation video](#) for guidance.

Prerequisites:

- Tools Required:
 - Insulated gloves
 - Phillips or flathead screwdrivers
 - DIN Rail (Recommended, Standard 35mm)
- Accessory Verification:
 - CTH01 Device
 - Power Adapter
 - Power Terminal Block
 - Power Terminal Wire
 - Mounting Screw Kits
 - Current Transformers: split-core CTs (100A, 300A, 500A, 1000A) or Rogowski Coils (Customizable)
 - Voltage Terminal Block (intrusive type)
 - Magnetic Voltage Measuring Cable (magnetic type)
 - Voltage Measurement Wires (User-supplied)
- Optional Accessories:
 - Magnetic Nuts

Warning:

- Only qualified professional electricians are allowed to install this device. High voltage may be present and can be life-threatening!
- The main power supply of the target distribution box or circuit must be cut off. After power-off, wait for at least 5 minutes to ensure the circuit capacitors are fully discharged!
- Use insulated tools and wear insulating gloves throughout the process, and strictly comply with local electrical safety regulations.
- Do not install or use it in damp, flammable, explosive, or corrosive environments.
- When connecting voltage lines, treat them as potentially live even after power is off. Use insulated tools and wear appropriate Personal Protective Equipment (PPE).

Steps:

1. CTH01 Mounting:

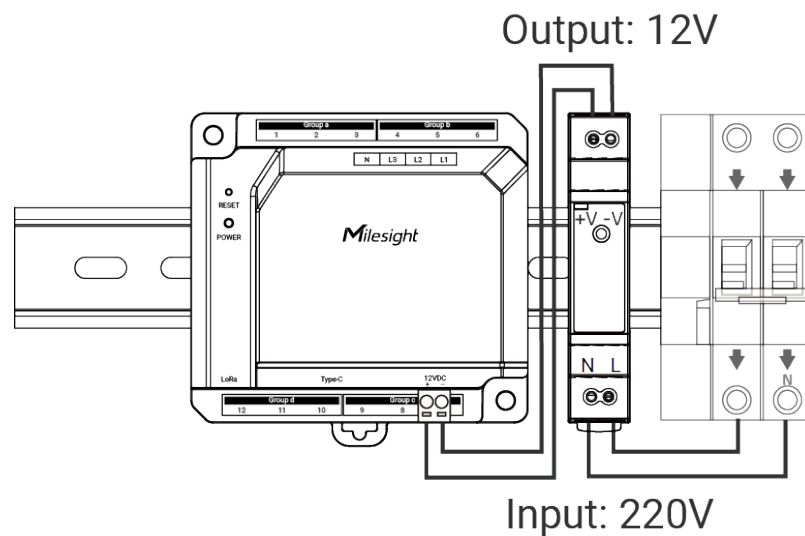

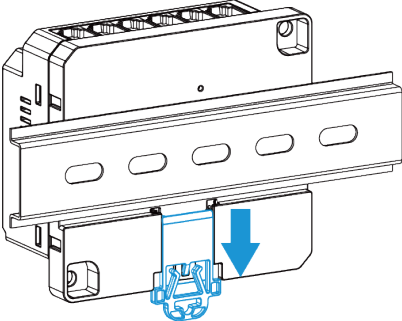
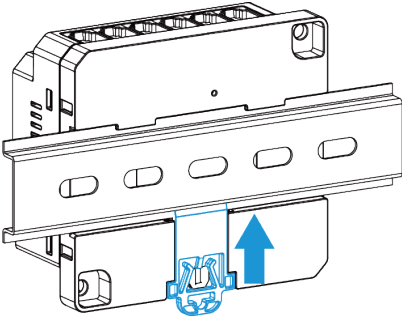
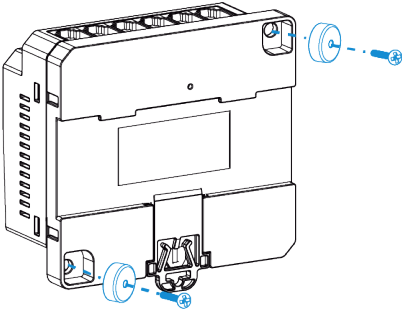
If	Do
<p>DIN Rail Mounting (Standard)</p>	<p>a. Fix a standard 35mm DIN rail to a suitable location inside the distribution board.</p>  <p>b. Align the upper clip on the back of the CTH01 with the rail and hook it on with an upward tilt.</p> <p>c. Press the bottom of the device downwards until the bottom clip snaps securely onto the rail with an audible "click".</p> 
<p>Magnetic Nuts Mounting (Optional, for non-rail scenarios)</p>	<p>a. Align the mounting holes on the back of the device with the threaded posts of the magnetic nuts. Use the provided screws to secure the nuts to the device from the back.</p> 

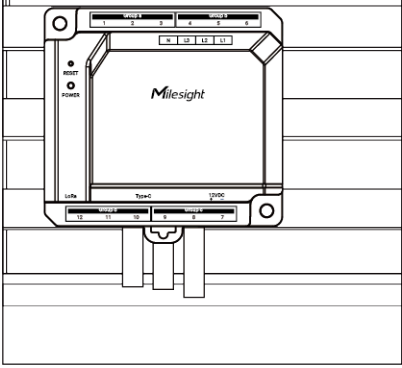
If	Do
	<p>b. The assembled CTH01 can then be directly attached by adsorbing the magnetic nuts onto the iron back-plate or the predetermined mounting position inside the distribution board.</p> 

2. Power Supply Connection:

- a. Mount the power adapter on a DIN rail.

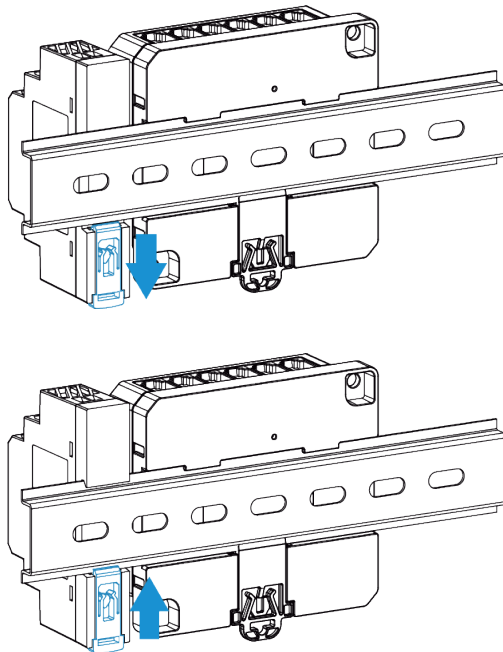

- b. Insert one end of the power terminal wire into the power terminal block, tighten the screw with a flathead screwdriver, and connect it to the power interface of the CTH01, ensuring a secure connection. Connect the other end of the power terminal wire to the upper interface of the power adapter and tighten the screw with a flathead screwdriver as well.

- c. Connect the lower interface of the power adapter to the circuit breaker inside the distribution box.

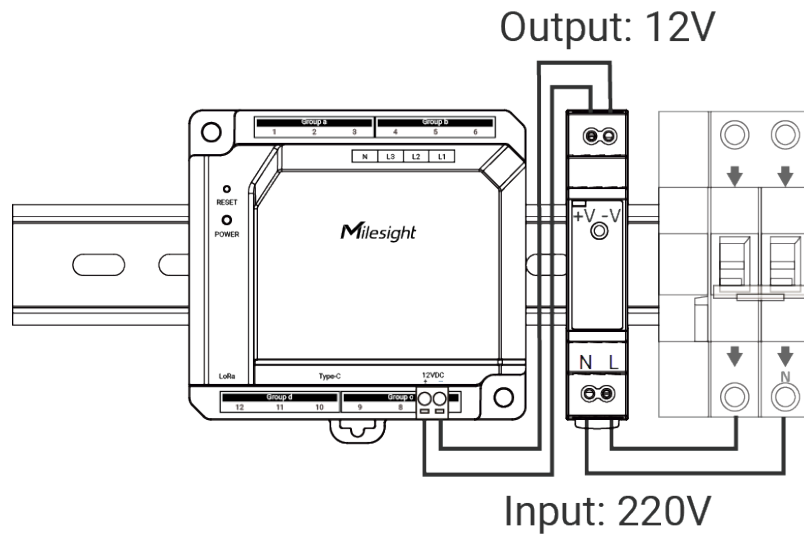

CAUTION:

Please follow the steps and diagrams carefully when connecting the upper and lower terminal wires of the power adapter. **Incorrect wiring may damage the device.**

3. Voltage Input Connection:

- a. Choose the correct [wiring method](#) for your power system.
- b. Connect voltage cables.

If	Do
Intrusive Connection (Standard)	<ol style="list-style-type: none"> a. Prepare voltage measurement wires (three-phase lines and the neutral line). Strip off the insulation to expose a suitable length of copper wire. b. Remove the voltage terminal block, press and hold the orange button, insert the voltage measurement wire into the corresponding port, and then release the button to secure the connection.

If	Do
----	----

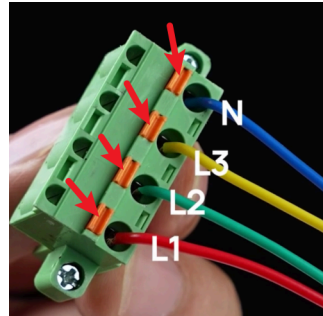

- c. Insert the assembled voltage terminal block into the voltage channel at the top of the CTH01. Tighten the terminal block screws with a small screwdriver to ensure a secure connection and no exposed copper wire.
- d. Connect the other end of the voltage measurement wires to the output terminal of the dedicated circuit breaker inside the distribution box.

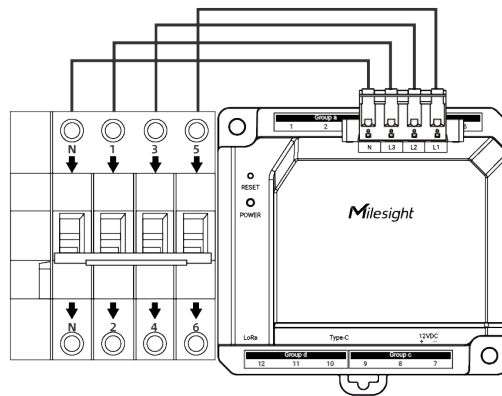

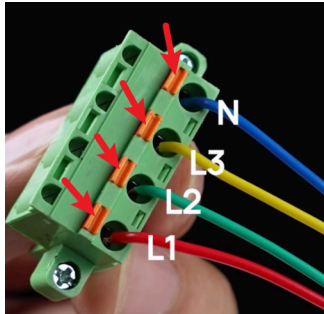
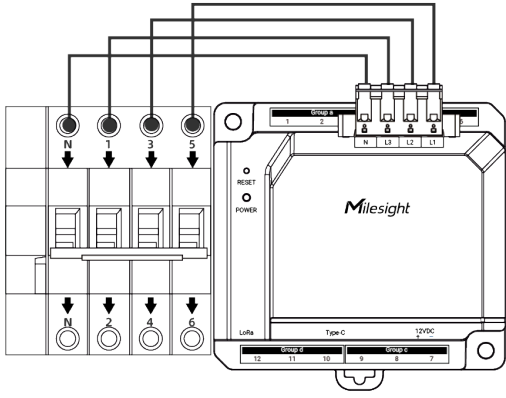
If	Do
<p>Magnetic Connection (Optional)</p>	<p>a. Remove the voltage terminal block, press and hold the orange button, insert the voltage measurement wire into the corresponding port, and then release the button to secure the connection.</p>  <p>b. Insert the assembled voltage terminal block into the voltage channel at the top of the CTH01. Tighten the terminal block screws with a small screwdriver to ensure a secure connection and no exposed copper wire.</p> <p>c. The other end of the magnetic voltage measurement cables can be directly attached to the screw of the dedicated circuit breaker output terminal inside the distribution box. Ensure the magnetic contact surface is clean and firmly attached.</p> <p>d. Ensure the magnetic contact surfaces are clean and the clips are firmly attached.</p> 

If	Do
	

4. Current Transformer Connection:

- a. Check the Current and Voltage Channel Mapping.

Voltage Channel	Must Use Current Channel (by group position)
L1	The 1st channel of any group: Ch1, Ch4, Ch7, or Ch10
L2	The 2nd channel of any group: Ch2, Ch5, Ch8, or Ch11
L3	The 3rd channel of any group: Ch3, Ch6, Ch9, or Ch12



Note:

If you connect, for example, L1 voltage with Ch2 current, the device will still show voltage and current values, but **calculated values will be wrong**, including:

- Power factor
- Active / reactive / apparent power
- Imported / exported / apparent energy

- b. Confirm whether the circuit to be monitored is single-phase or three-phase.

Single-phase: Each channel can be used independently, with no grouping restrictions.

Three-phase: MUST use 3 channels from the same group (e.g., use Ch1, Ch2, Ch3 of Group a for L1, L2, L3 phases respectively).

Mixed: Different ratings of standard CTs (e.g., 100A, 300A) can be mixed within the same group. However, if any channel in a group uses a Rogowski Coil, then ALL channels in that group must use Rogowski Coils.

- c. Place the current transformer around the wire to be measured.

- If you use split-core CT, open the clamp and place it around the conductor to be measured. Ensure the conductor is centered, and the arrow on the clamp points towards the **load side** (direction of current flow).

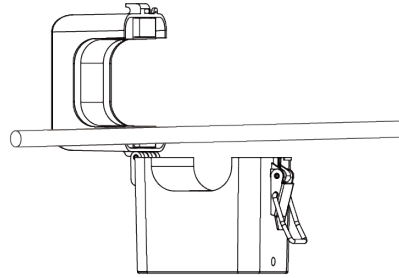

①

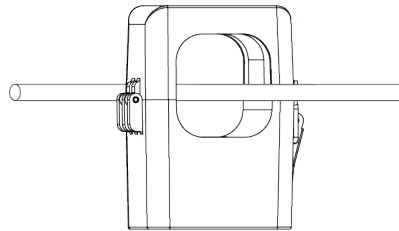

②



- If you use Rogowski Coil, open the Rogowski coil and place it around the busbar to be measured. Ensure the busbar is centered, and the arrow on the clamp points towards the **load side** (direction of current flow).

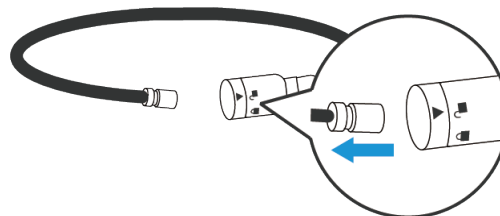

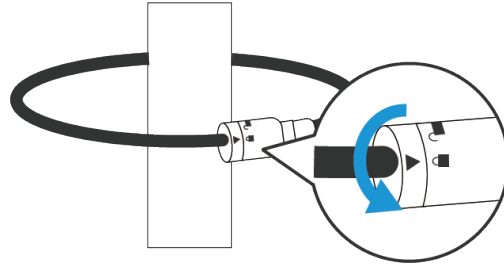

- d. Close the current transformer until it locks with an audible "click."
- e. Firmly insert the RJ11 plug of the current transformer into the corresponding numbered RJ11 port on the current channels of CTH01.

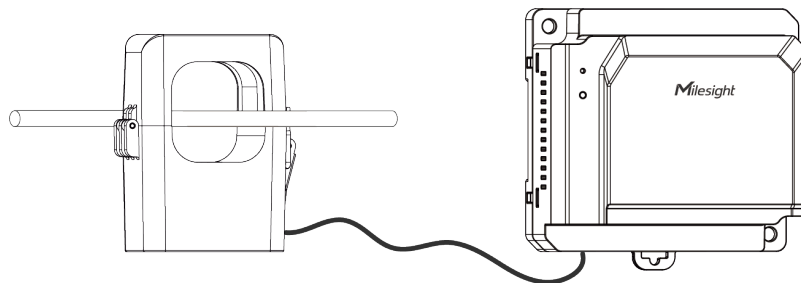

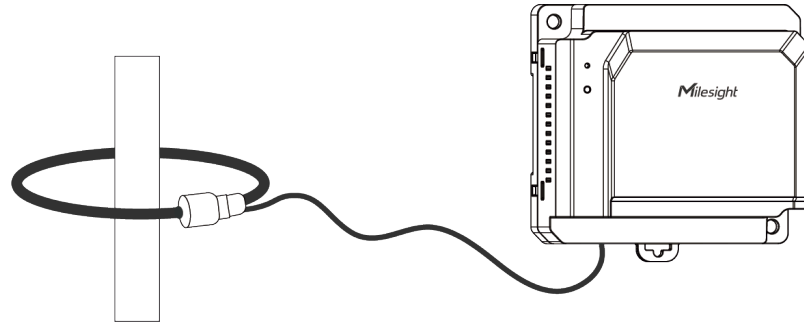

Tip:

For future maintenance, it is recommended to label the current transformer cables to indicate the monitored circuit.

5. Antenna Installation:

- a. Align the SMB connector of the provided magnetic antenna with the LoRaWAN[®] magnetic antenna interface on CTH01.
- b. Press gently straight down until a faint "click" is heard, indicating a secure connection.
- c. Place the antenna vertically or attach it vertically via its magnetic base to the exterior of the distribution board or a metal surface with good signal reception. Ensure the antenna cable is laid naturally without pinching.
- d. Keep the antennas away from walls and ensure there are no obstacles around them.

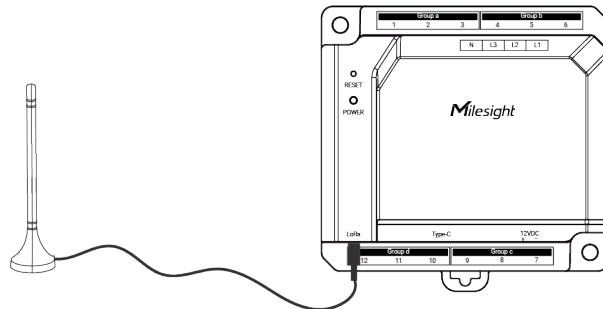

Tip:

- For better coverage, it is recommended to position the antennas at a higher location.
- Place the antennas near windows when used indoors.

6. (Optional) USB-C NTC Sensor Installation:

- a. Connect the Type-C connector of the wire temperature sensor to the USB-C port on CTH01.
- b. Use the provided zip tie to securely fasten the sensor onto the surface of the conductor or busbar to be monitored. Ensure the NTC sensor head has good contact with the conductor or busbar surface.

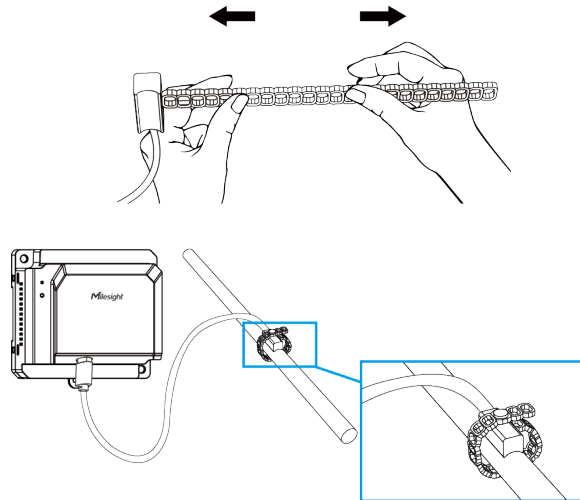

7. Post-Installation Checklist.

Before reapplying power, verify each item:

- Main power supply is **OFF**.
- CTH01 is securely mounted.
- Power cable polarity is correct and connections are tight.
- Voltage wires are connected correctly, screws are tightened.
- All current transformer arrows point correctly, clamps are locked, and RJ11 plugs are fully inserted.
- Antenna is installed outside the enclosure and secured.
- All cables are neatly arranged without excessive strain.

If all items are confirmed, you may turn on the main power supply.

Chapter 4. ToolBox App Configuration

Access the Device Using Bluetooth

This section describes how to access the device using Bluetooth. The device can connect to only one phone via Bluetooth.



Note:

The Bluetooth connection will be terminated if there's no data interaction within 3 minutes. Please reconnect as needed.

Steps:

1. Download Milesight ToolBox app from Google Play or Apple Store.
2. Enable the Bluetooth and location function on the smart phone.
3. Launch ToolBox.
 - a. Upon initial launch, the following page will appear. Select **Bluetooth** and click **Enter**.

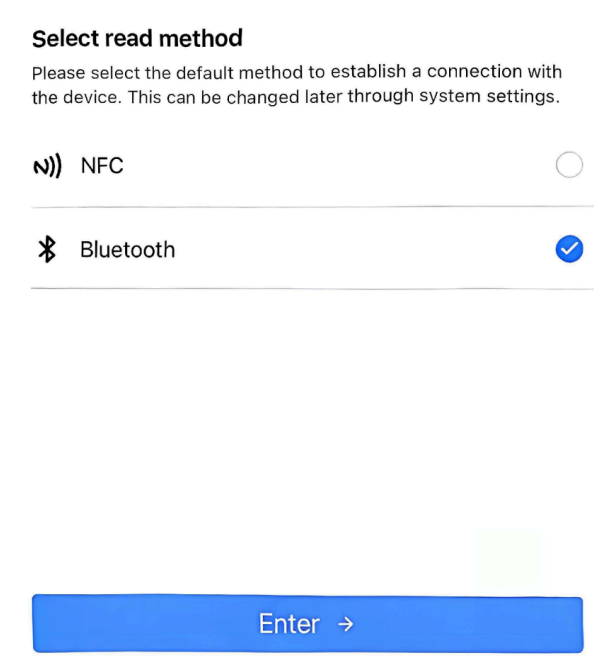

- b. Upon subsequent launches, Click **Maintenance** on the home page, and then select **Bluetooth**.

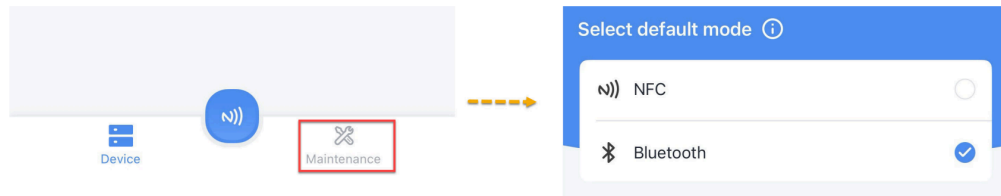

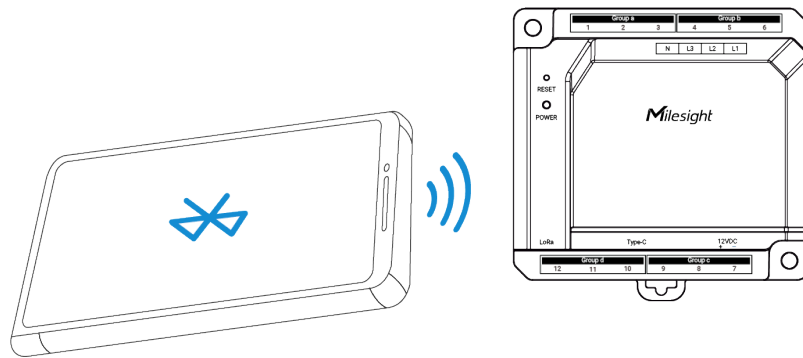

4. Click  to scan the devices around and select the target device to connect. The default Bluetooth name is model -XXXXXX (5th to 11 st of device SN) and the default device password is 123456.



Tip:

It is recommended to change a new password for security.

5. If the device is recognized successfully, the homepage is displayed. For a description of the homepage, refer to the following table.

Item	Description
Basic Information	Shows basic device information and sync the system time.
Setting	Sets the device and network parameters.
	Imports, adds, exports or deletes a template.
	Sets the language, shows NFC positions and checks the version.

Synchronize Device Time

This section describes how to sync the device time.

Synchronize the Time Manually Through ToolBox App

The device time can be synced via Milesight ToolBox App.

1. On the homepage of ToolBox, click **Basic Information**.
2. Click  to synchronize the time.



3. If the time is synchronized successfully, the following page is displayed.



Sync successfully!

Synchronize the Time Automatically Through a LoRaWAN[®] Network Server

Prerequisite: The LoRaWAN[®] network server supports the device time synchronization feature.

Steps:

1. Set the LoRaWAN[®] version of the device to **V1.0.3**. For details, refer to [Configure LoRaWAN[®] Parameters](#).
2. Connect the device to the network server. Once the device successfully joins the network, it sends a MAC command to query the time from the network server.



Note:

- This only supports getting the time, but not the time zone. The time zone can be configured by ToolBox App or downlink command.
- The device will send the DeviceTimeReq command every 5 days since the last sync.

Configure LoRaWAN[®] Parameters

This section describes how to configure the device transmission parameters for the LoRaWAN[®] network.

Usually, it consists of the below steps:

1. [Configure Join Type and Supported Frequency \(Necessary\)](#)
2. [Configure Other LoRaWAN[®] Parameters \(Optional\)](#)

Configure Join Type and Frequency

It is necessary to configure the join type and the frequency to establish communication with LoRaWAN[®] gateways.

Steps:

1. On the homepage of ToolBox, click **Setting** to enter the **Setting** page.
2. Navigate to the **LoRaWAN** page The **LoRaWAN** page is displayed, see the following figure.

LoRaWAN

Device EUI

24E124

* APP EUI

24e124c0002a0001

* Application Port

85

LoRaWAN Version

V1.0.3

Work Mode ⓘ

3. From the **Join Type** selection box, select **OTAA** or **ABP** as needed.



Note:

OTAA is required if you connect the device to the [Milesight Development Platform](#).

4. Configure **Join Type** related parameters as needed. You can use default values unless otherwise specified.

- If **OTAA** is selected, configure **Application Key** and **Rejoin Mode** as needed. For details, refer to the following table.

Parameter	Description
Application Key	<p>Appkey for OTAA mode. Default: Device EUI + Device EUI. Example: 24e124123456789024e1241234567890.</p> <div style="border: 1px solid #ccc; border-radius: 10px; background-color: #e6f2ff; padding: 10px; margin-top: 10px;"> <p> Tip: Contact sales before purchase if you need random App keys.</p> </div>
Rejoin Mode	Rejoin mode for OTAA mode.

Parameter	Description
	<p>Reporting interval ≤ 35 minutes: The device sends a specific number of LinkCheckReq MAC packets at each reporting interval or every other reporting interval to verify connectivity.</p> <p>Reporting interval > 35 minutes: The device sends a specific number of LinkCheckReq MAC packets at each reporting interval to validate connectivity. If there is no response, the device will re-join the network.</p> <p>When Rejoin Mode is enabled, enter a number in the Set the number of detection signals sent text box. The actual sending number is the configured number +1.</p>

- If **ABP** is selected, configure **Network Session Key**, **Application Session Key** and **Device Address** as needed. For details, refer to the following table.

Parameter	Description
Network Session Key	Nwkskey for ABP mode. Default: 5572404C696E6B4C6F52613230313823.
Application Session Key	Appskey for ABP mode. Default: 5572404C696E6B4C6F52613230313823.
Device Address	DevAddr for ABP mode. Default: 5 th to 12 th digits of SN.

5. Select a frequency from the **Support Frequency** selection box as needed. This must be the same as the frequency configured on the gateway's web GUI.

- If the **Supported Frequency** is **CN470**, **US915** or **AU915**, enter the channel index(es) separated by commas.

Examples:

1, 40: Enabling Channel 1 and Channel 40

1-40: Enabling Channel 1 to Channel 40

1-40, 60: Enabling Channel 1 to Channel 40 and Channel 60

All: Enabling all channels

Null: All channels are disabled



Tip:

Set the **Channel Index** to **8-15** when connecting to a Milesight LoRaWAN[®] gateway with default settings.

- If the **Supported Frequency** is **AS923**, select a channel plan and enable the frequencies as needed.
 - If the **Supported Frequency** is any option other than those listed above, enable the frequencies as needed.
6. Click **Write** in the lower right corner. If the configuration succeeds, the following page is displayed.



Write successfully!

Configure Other LoRaWAN[®] Parameters

Steps:

1. On the homepage of ToolBox, click **Setting** to enter the **Setting** page.
2. Navigate to the **LoRaWAN** page The **LoRaWAN** page is displayed, see the following figure.

LoRaWAN

Device EUI

24E124

* APP EUI

24e124c0002a0001

* Application Port

85

LoRaWAN Version

V1.0.3

Work Mode ⓘ

3. Configure the following parameter as needed. You can use default values unless otherwise specified. For a description of the parameters, refer to the following table.

Parameter	Description
Device EUI	Unique ID of the device labelled on the device housing. <div style="border: 1px solid #ccc; background-color: #e6f2ff; padding: 5px; margin-top: 10px;">  Tip: For bulk deployments, contact sales to request the device EUI list. </div>
App EUI	The default App EUI (join EUI) is 24E124C0002A0001.
Application Port	Port used for sending and receiving data. Default: 85 .
LoRaWAN [®] Version	Options: V1.0.2, V1.0.3 .
Work Mode	It is fixed in Class C mode.
Confirmed Mode	If the device does not receive ACK packet from network server, it will re-send data once.
Join Type	Refer to Configure Join Type and Supported Frequency .

Parameter	Description
Supported Frequency	Refer to Configure Join Type and Supported Frequency .
ADR Mode	Enables the network server to adjust the spreading factor, the bandwidth and the transmission power to optimize data rates, airtime and energy consumption in the network.
Spreading Factor	If ADR mode is disabled, the device sends uplink data using this spreading factor. A higher spreading factor increases transmission range but reduces data rate and increases power consumption. This parameter varies with Supported Frequency .
Tx Power	Defined by the LoRa Alliance. Specifies the strength of the radio signal transmitted by the device.
RX2 Data Rate	RX2 data rate to receive downlinks.
RX2 Frequency	RX2 frequency to receive downlinks. Unit: Hz

4. Click **Write** in the lower right corner. If the configuration succeeds, the following page is displayed.



Write successfully!

Configure the Device Parameters

This section describes how to configure the device.

Change the Device Password

It is recommended to change the device password upon initial configuration for security purposes. This section describes how to change the device password.

Steps:

1. On the homepage of ToolBox, click **Setting** to enter the **Setting** page.
2. On the top bar, select **Device** tab.

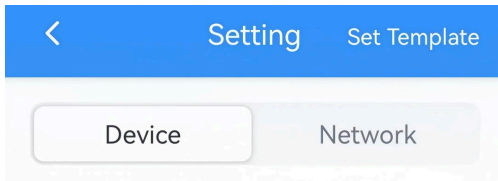

3. In the **General** page, enable **Change Password** and enter the new password.

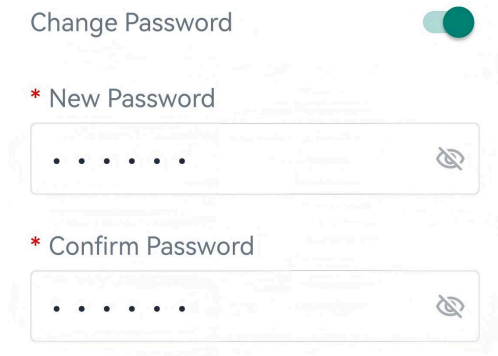

Parameter	Description
New Password	Enter a new password of 6 characters. Only letters, digits, and underscores are allowed.
Confirm Password	Enter the password again.

4. Click **Write** in the lower right corner. If the configuration succeeds, the following page is displayed.



Write successfully!

Configure General Parameters

This section describes how to configure the general parameters of the device, which includes:

- Reporting Interval
- Data Storage
- Data Retransmission
- Time Zone
- Daylight Saving Time
- Bluetooth Name
- Device password

Steps:

1. On the homepage of ToolBox, click **Setting** to enter the **Setting** page.
2. On the top bar, select **Device** tab.

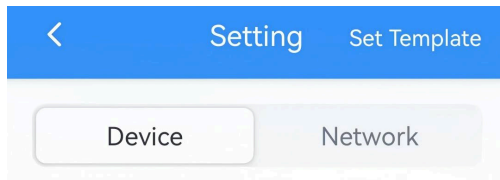

3. In the **General** page, configure the following device parameters as needed.

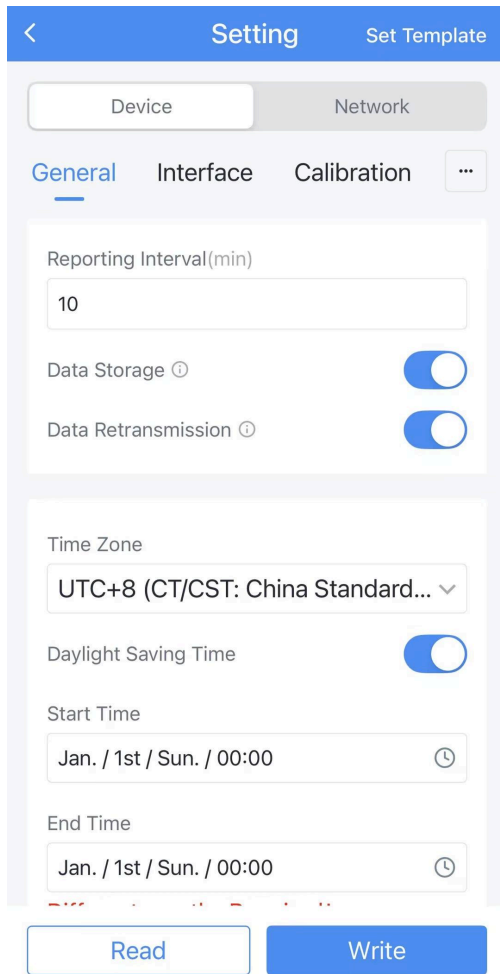

Parameter	Description
Reporting Interval	The interval to report data to network server. Range: 1~1440 min, Default: 10 min.
Data Storage	Disables or enables data storage. For details, refer to Configure the Data Storage&Retransmission .
Data Re-transmission	Disables or enables data retransmission. For details, refer to Configure the Data Storage&Retransmission .
Time Zone	Select the UTC time zone. When you click Sync button of ToolBox App to sync time, the device will also sync the time zone from smart phone automatically.
Daylight Saving Time	Enable or disable Daylight Saving Time (DST).

Parameter	Description
	<p>Start Time: The start time of DST time range.</p> <p>End Time: The end time of DST time range.</p> <p>DST Bias: The DST time will be faster according to this bias.</p>
Bluetooth Name	Change the Bluetooth name of the device.
Device password	Change the password for ToolBox App to log in this device.

4. Click **Write** in the lower right corner. If the configuration succeeds, the following page is displayed.



Write successfully!

Related information

[Commands for General Settings](#)

Configure Interface Parameters

This section describes how to configure the interface parameters of the device, which includes:

- Current
- Voltage

Steps:

1. On the homepage of ToolBox, click **Setting** to enter the **Setting** page.
2. On the top bar, select **Device** tab.

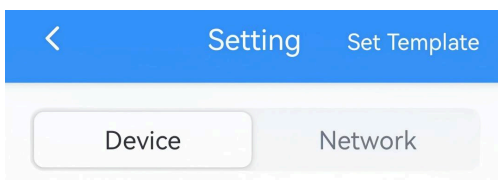

3. In the **Interface** page, configure the following device parameters as needed.

Parameter	Description
Voltage Channel	
Wiring Configuration	<p>Choose the correct wiring method for your power system.</p> <ul style="list-style-type: none"> ◦ 3P4W: Three phase wires and one neutral wire are used, suitable for both three-phase and single-phase loads. ◦ 3P3W: Three live wires and no neutral wire, typically used for delta-connected loads.
Current Channel	
Circuit Type	<p>Choose the correct wiring method for your current transformers.</p> <ul style="list-style-type: none"> ◦ Single-Phrase: Uses one phase wire and one neutral wire (L+N), suitable for general home and office low-load usage. ◦ Three-Phrase: Uses three phase wires and one neutral wire (L1, L2, L3, N), ideal for high-power or industrial loads.
Channel Current Range	The range of current values that the channel can accurately measure.

Parameter	Description
	When a channel is set to the special range of 4000A, the other two channels in the same group will be synchronized to 4000A. When switching from 4000A to another range, the other two channels in the group will also be synchronized accordingly.
Current Direction	If the installation does not follow the arrow direction of split-core CTs or Rogowski coils, the measured current value will be negative. Click here to reverse the current direction.

4. Click **Write** in the lower right corner. If the configuration succeeds, the following page is displayed.



Write successfully!

Configure Calibration Parameters

This section describes how to configure the calibration parameters.

Temperature Calibration

The device supports adding calibration values to the current temperature values, then display and report the final values.

Prerequisites: External USB-C NTC Sensor installation completed.

Steps:

1. On the homepage of ToolBox, click **Setting** to enter the **Setting** page.
2. On the top bar, select **Device** tab.

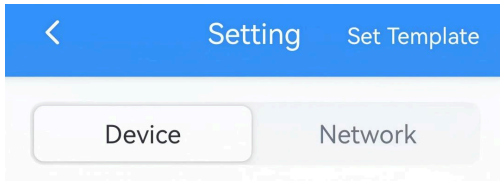

3. In the **Calibration** page, enable **Temperature** and enter a **Calibration Value**. The following page is displayed.

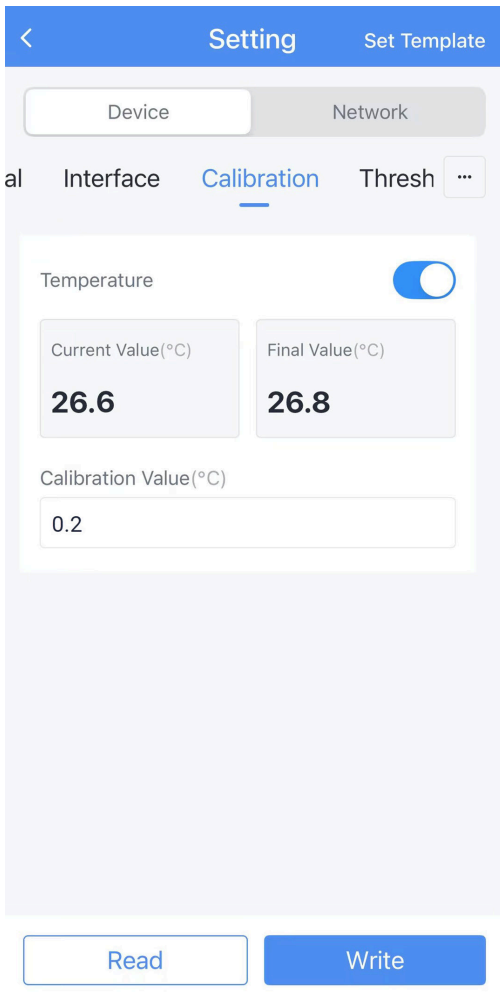

4. Click **Write** in the lower right corner. If the configuration succeeds, the following page is displayed.



Write successfully!

Related information

[Commands for Calibration Settings](#)

Configure Threshold Parameters

Threshold Alarms

This section describes how to configure threshold parameters.

Steps:

1. On the homepage of ToolBox, click **Setting** to enter the **Setting** page.
2. On the top bar, select **Device** tab.

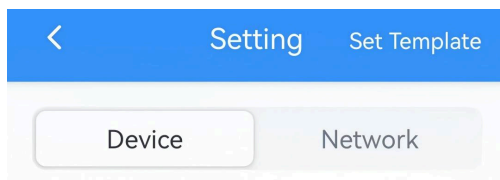

3. In the **Threshold** page, select threshold type as needed, proceed to the input page, enter at least one threshold value. The following page is displayed.

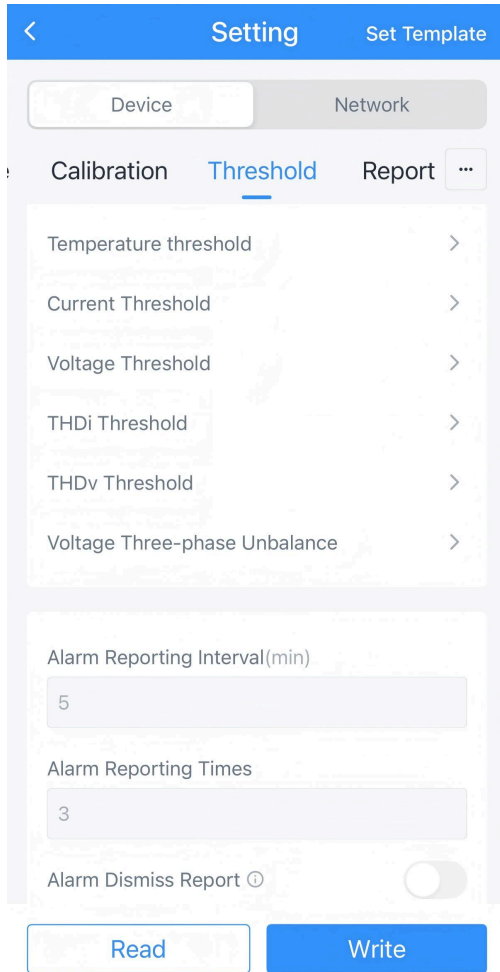

4. Configure the following threshold report parameters.

Parameters	Description
Alarm Reporting Interval	The time interval between the initial alarm and subsequent alarms triggered when the threshold is reached. Default: 5 minutes. Alarm reporting interval must be shorter than the reporting interval.
Alarm Reporting Times	Alarm packet report times after threshold alarm triggers. Default is 3.
Alarm Dismiss Report	When enabled, the device reports an alarm dismiss packet once the reading returns to within the threshold range.

5. Click **Write** in the lower right corner. If the configuration succeeds, the following page is displayed.



Write successfully!

Result *(Temperature as example):*

Above Threshold: When the conductor or busbar temperature exceeds the Above threshold value, the device immediately sends a threshold alarm packet; when the conductor or busbar temperature falls to the Above threshold value, the device sends an alarm release packet.

Below Threshold: When the conductor or busbar temperature falls below the Below threshold value, the device immediately sends a threshold alarm packet; when the conductor or busbar temperature exceeds the Below threshold value, the device sends an alarm release packet.

Passive Alarms

Out-of-Range Alarm: When the device detects that the actual current or voltage exceeds the rated range, an overrange alarm is triggered and reported immediately. The alarm will be reported three times at fixed intervals of 5 minutes.

Power Failure Alarm: When the device supply voltage drops from 12V to 0V, a power-off alarm is triggered and reported immediately, with a total of two consecutive reports. No further reports will be sent until the device shuts down due to power loss.

Related information

[Command for Threshold Settings](#)

[Alarm Report](#)

Configure Report Parameters

This section describes how to configure the interface parameters of the device, which includes:

- Temperature
- Current(RMS)
- Voltage(RMS)
- Power Factor
- Active Power
- Reactive Power
- Apparent Power
- Imported Active Energy
- Exported Active Energy
- Imported Reactive Energy
- Exported Reactive Energy
- Apparent Energy
- THDi
- THDv
- Voltage Three-phase Unbalance

Steps:

1. On the homepage of ToolBox, click **Setting** to enter the **Setting** page.
2. On the top bar, select **Device** tab.

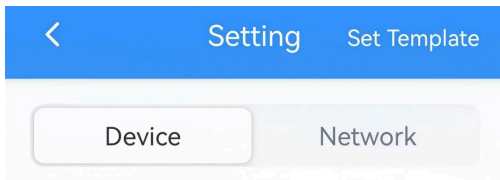

3. In the **Report Parameters** page, enable the parameters to collect and report as needed.

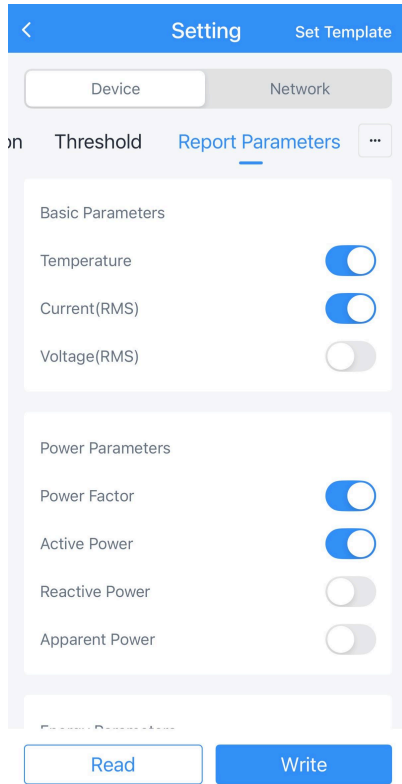

Parameter	Description
Basic Parameters	
Temperature	The measured temperature of conductor through USB-C NTC Sensor. The data reports by default. The device collects the data every 1 second, and the interval cannot be changed. Unit: °C
Current(RMS)	The measured current of 12 channels of conductor or busbar. The data is collected directly from the device at 1-second intervals and cannot be modified. Unit: A
Voltage(RMS)	The measured 3 channels voltage. The data is collected directly from the device at 1-second intervals and cannot be modified. Unit: V
Power Parameters	
Power Factor	The ratio of Active Power to Apparent Power ($\cos \phi$), indicating the efficiency of electrical power utilization. The data reports by default. Range: 0-100. Unit: %.
Active Power	The real power that is consumed or generated to perform actual work. The data reports by default. Unit: W.

Parameter	Description
Reactive Power	The power that does not perform actual work but supports the operation of the electrical system. Unit: VAR.
Apparent Power	The product of voltage and current, combining active and reactive power. Unit: VA.
Energy Parameters	
Imported Active Energy	The total active energy imported from the grid. The data reports by default. Unit: Wh.
Exported Active Energy	The total active energy exported to the grid. Unit: Wh.
Imported Reactive Energy	The total reactive energy imported from the grid. Unit: VARh.
Exported Reactive Energy	The total reactive energy exported to the grid. Unit: VARh.
Apparent Energy	The total apparent energy measured. Unit: VAh.
Power Quality Parameters	
THDi	Total harmonic distortion of current, indicating the distortion level. Unit: %.
THDv	Total harmonic distortion of voltage, indicating the voltage waveform distortion level. Unit: %.
Voltage Three-phase Unbalance	The deviation among the three-phase voltages. Unit: %.

4. Click **Write** in the lower right corner. If the configuration succeeds, the following page is displayed.



Write successfully!

Related information[Command for Report Parameters](#)

Configure Data Storage & Retransmission

The device supports data storage and data retransmission to ensure data integrity. This section describes how to configure data storage and data retransmission.

Export the Local Data

The device supports storing historical data records locally, which operates normally even when the network is deactivated.

Each device can store up to 20,000 data records.

Prerequisites: [Sync the time](#) to ensure the data is stored in correct time.

Steps:

1. On the homepage of ToolBox, click **Setting** to enter the **Setting** page.
2. On the top bar, select **Device** tab.

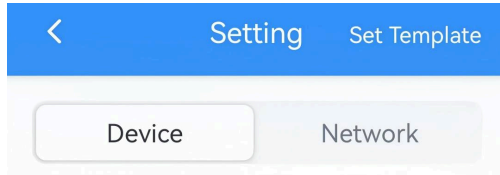

3. In the **General** page, enable **Data Storage**.
4. Return to the homepage and click **Maintenance** in the lower right corner.
5. Click **History Data**, select data export type and time range, click **Export** in the low right corner to read data.

**Tip:**

- Since the ToolBox App's data export time range is limited to 14 days, you can export the complete data in segments if the required time range exceeds this limit.
- Click  in the top right to check the history export records.

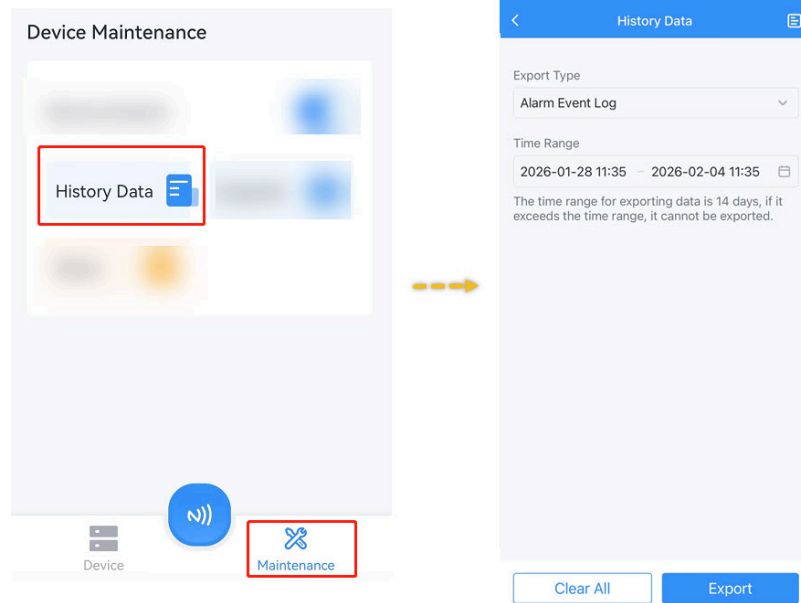

6. Click **Export** to customize a file name, then click **OK** to save the history data as a CSV file to your smartphone.

Enable Data Retransmission

Data retransmission allows the network server to receive data, even after temporary network outages.

Prerequisites: The device join type is **OTAA**.

Steps:

1. On the homepage of ToolBox, click **Setting** to enter the **Setting** page.
2. On the top bar, select **Network** tab.

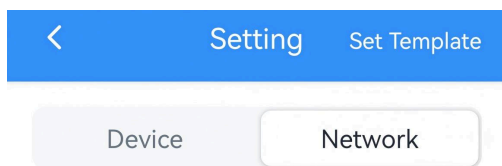

3. In the **LoRaWAN** page, enable **Rejoin Mode** and set the number of packets sent.

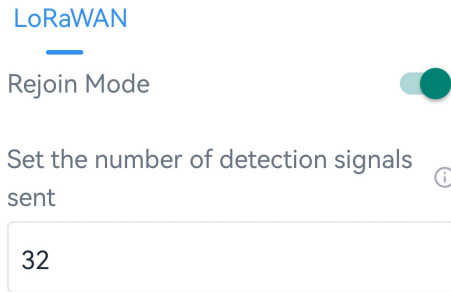

4. On the top bar, select **Device** tab.

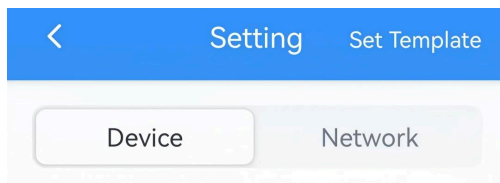

5. In the **General** page, enable **Data Storage** and **Data Retransmission**.

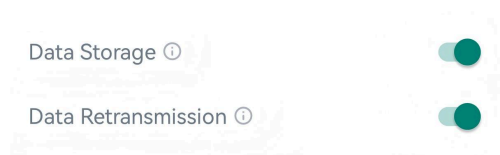

6. Click **Write** in the lower right corner. If the configuration succeeds, the following page is displayed.



Write successfully!

Result:

When the device detects the network status is deactivated via rejoin mode mechanism, the device will record a data lost time point and re-transmit the lost data according to data retransmission interval after device re-connects to the network. The reported format of retransmission data will include timestamps and is different from periodic report data.

**Note:**

- Data retransmission increases the uplink traffic.
- If the device reboots or re-power during data retransmission, it will resend the entire retransmission dataset after reconnecting to the network.
- If a new network disconnection occurs during an ongoing retransmission, only the data logged during this latest outage will be sent upon reconnection.
- The default report data retransmission interval is 600s, this can be changed via downlink command.

Query Historical Data

The device supports data retrievability feature to query historical data for a specific time range via downlink command. The retransmission data format includes timestamps and differs from the periodic report format. For details, refer to [Commands for Historical Data Query](#).

Related information

[Commands for General Settings](#)

Maintain the Device

This section describes how to maintain the device.

Upgrade the Device

The device supports local upgrades via Bluetooth as well as remote FUOTA (Firmware Update Over the Air) through LoRaWAN[®] network servers. For detailed instructions on the FUOTA process, please refer to the respective server documentation. This section describes how to upgrade the device locally.

Prerequisites: Download firmware from [Milesight official website](#) and save it to the smart phone. It is recommended to consult technical support before upgrading to ensure a safe and successful upgrade.

Steps:

1. On the homepage of ToolBox, click **Maintenance** in the lower right corner.
2. Click **Upgrade** to go to **Upgrade** page.
3. Click **Upload** to select the firmware from the local path of the smartphone.

4. Click **Upgrade** to upgrade the device.

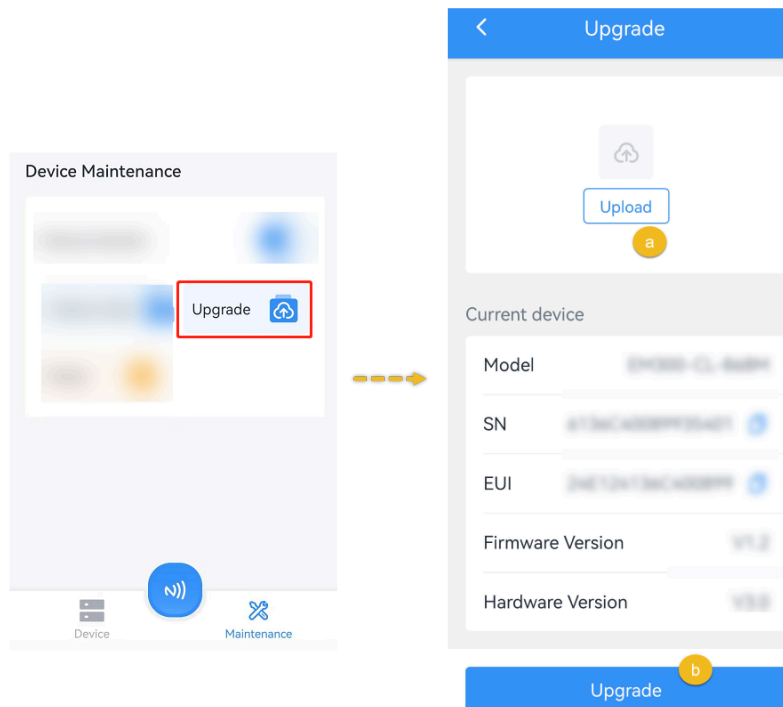

Configure a Template for Configuration Backup

This device supports configuration backup, which enables quick and easy batch configuration. This section describes how to backup the device configuration and write to other devices.

Prerequisites: The backup device and the device importing the backup are exactly the same model.

Step 1. Set a Template

1. Access the device via ToolBox App.
2. On the homepage of ToolBox, click **Setting** to enter the **Setting** page.
3. Edit the device parameters as required, click **Set Template** in the top right corner.
4. Customize a template name, click **Confirm** to save the current configuration as a template.

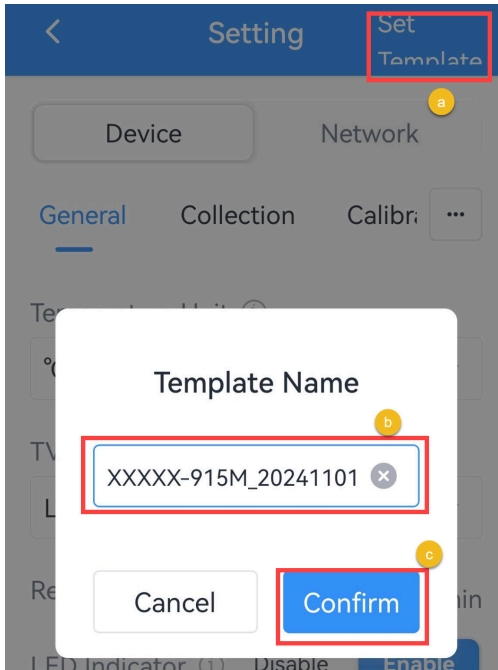

5. If the save is successful, the following page is displayed. The template will be saved to the ToolBox App.

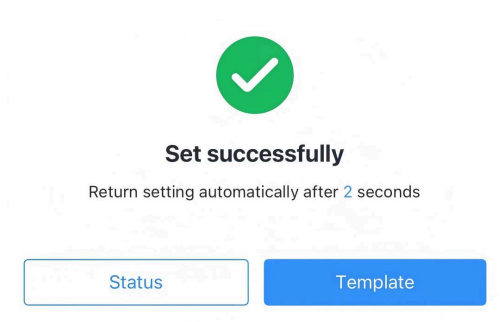

Step 2. Write Template Configuration to the Target Device

1. On the homepage of ToolBox, click **Device** in the lower left corner.
2. Click Template icon in the top right corner to go to **Template** page.



3. Click the saved template. Do not select the template.

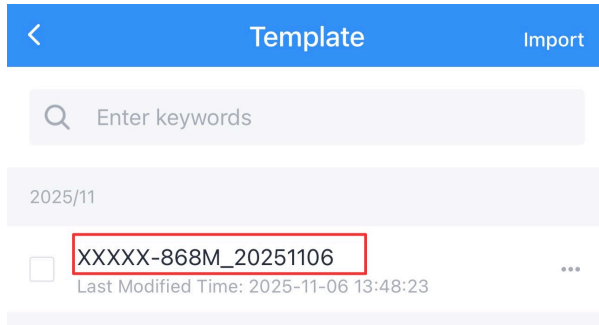

4. In the displayed page, click **Write** in the bottom. If the configuration is written to the target device, the following page is displayed.



Write successfully!

Step 3. Export or Delete a Template (Optional)

1. Select the checkbox of the target template as shown in the following figure.

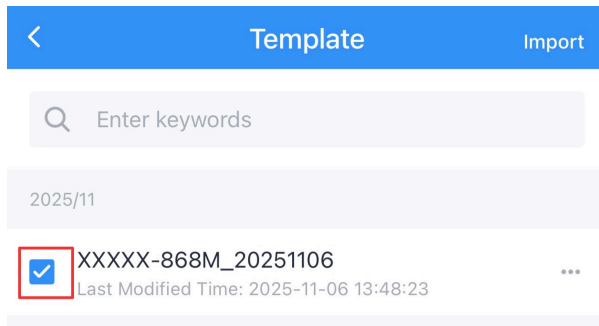

2. Click **Export** in the lower left corner to export this template as a JSON format file and save it to the smart phone.
3. Click **Delete** in the lower right corner, then click **Confirm** to delete this template from ToolBox.

Reset the Device

This section describes how to reset the device.

Steps:

1. On the homepage of ToolBox, click **Maintenance** in the lower right corner. The **Maintenance** page is displayed, see the following figure.

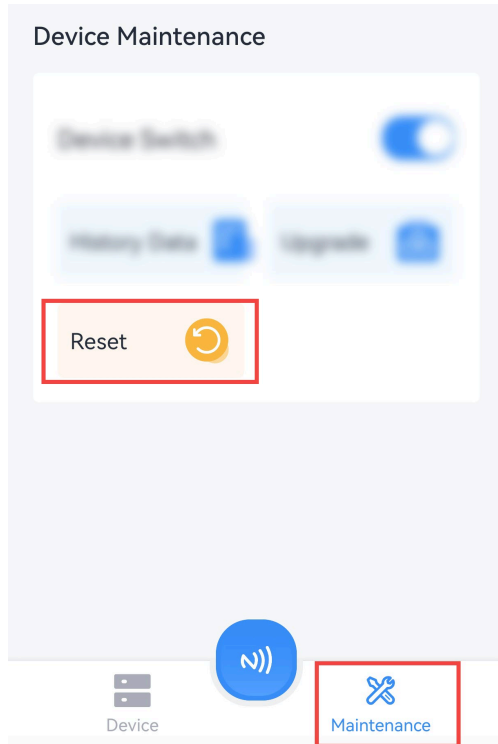

2. Click **Reset**.
3. In the displayed dialog box, click **Confirm**.
4. If the device is successfully reset, the following page is displayed.



Reset successfully!



Note:

If unable to read or write devices normally using the ToolBox, perform a [hardware reset](#).

Chapter 5. Uplink Packets and Downlink Commands

This chapter describes that uplink data packet and downlink commands supported by the device.

All messages follow the following format (HEX), the Parameter/Data field must follow **little-endian** byte order:

Command ID	Parameter/Data	...
N Bytes	0-N Byte	...

For decoder and encoder examples, please find files on <https://github.com/Milesight-IoT/SensorDecoders>. For details of uplink reports and downlink commands please refer to the sections below.

Uplink Packets

This section describes the uplink packets reported by the device.

Basic Information Packet

After joining the network, the device reports a packet containing the basic device information, totaling four reports.

Packet description:

Item	Byte	Command	Description
TSL Version	1+2	df	Example: 01 02 = V1.2
Device Request	1	ee	Report only after reset
Serial Number	1+8	db	16 digits
Device Version	1+8	da	Hardware version (2B) + Software version (2B) + 00000000
OEM ID	1+2	d9	4 digits
Device Status	1+1	c8	00: Off, 01: On
Work Mode	2+1	cf00	00: Class A, 01: Class B, 02: Class C, 03: Class C to B

Example:

df0100 ee db6527f41809380000 da0100010100000000 d90000 c801 cf0002	
Command	Value
df	TSL Version: 01 00 => V1.0
ee	Reset
db	SN: 6527f41809380000
da	Hardware Version: 0100 => V1.0 Software Version: 0101=> V1.1
d9	OEM ID: 0000
c8	01: Device is on
cf00	02: Class C

Periodic Data Packet

Normally Periodic Data Packet

The device reports a sensor data packet at a configured interval.

Packet description:

Item	Byte	Command	Description
Temperature	1+2	01	INT16/100, Unit: °C, Range: -20 - 100
Voltage Three-Phase Unbalance	1+2	02	UINT16/100, Unit: %, Range: 0 - 100
Current Total Harmonic Distortion (THDi)	1+24	03	12 channels with each channel reports: UINT16/100, Unit: %, Range: 0 - 100
Voltage Total Harmonic Distortion (THDv)	1+6	04	3 channels with each channel reports: UINT16/100, Unit: %, Range: 0 - 100
RMS Current	1+24	05	12 channels with each channel reports: UINT16/100, Unit: A

Item	Byte	Command	Description												
RMS Voltage	1+6	06	3 channels with each channel reports: UINT16/100, Unit: V												
Power Factor	1+13	07	<p>Byte 1:</p> <p>For every bit: 1=Single-Phrase, 0=Three-Phrase</p> <table border="1"> <thead> <tr> <th>Bit</th> <th>Description</th> </tr> </thead> <tbody> <tr> <td>0</td> <td>Group a</td> </tr> <tr> <td>1</td> <td>Group b</td> </tr> <tr> <td>2</td> <td>Group c</td> </tr> <tr> <td>3</td> <td>Group d</td> </tr> <tr> <td>4-7</td> <td>0000</td> </tr> </tbody> </table> <p>Byte 2-13: Power Factor. 12 channels with each channel reports: UINT8, Unit: %, Range: 0 - 100</p>	Bit	Description	0	Group a	1	Group b	2	Group c	3	Group d	4-7	0000
Bit	Description														
0	Group a														
1	Group b														
2	Group c														
3	Group d														
4-7	0000														
Active Power (Group a+b)	1+25	08	<p>Byte 1:</p> <p>For every bit: 1=Single-Phrase, 0=Three-Phrase</p>												
Active Power (Group c+d)	1+25	09	<table border="1"> <thead> <tr> <th>Bit</th> <th>Description</th> </tr> </thead> <tbody> <tr> <td>0</td> <td>Group a/c</td> </tr> <tr> <td>1</td> <td>Group b/d</td> </tr> <tr> <td>2-7</td> <td>000000</td> </tr> </tbody> </table> <p>Byte 2-5/6-9/10-13/14-17/18-21/22-25: Active Power. 6 channels with each channel reports: INT32, Unit: W</p>	Bit	Description	0	Group a/c	1	Group b/d	2-7	000000				
Bit	Description														
0	Group a/c														
1	Group b/d														
2-7	000000														
Reactive Power (Group a+b)	1+25	0a	<p>Byte 1:</p> <p>For every bit: 1=Single-Phrase, 0=Three-Phrase</p>												
Reactive Power (Group c+d)	1+25	0b	<table border="1"> <thead> <tr> <th>Bit</th> <th>Description</th> </tr> </thead> <tbody> <tr> <td>0</td> <td>Group a/c</td> </tr> </tbody> </table>	Bit	Description	0	Group a/c								
Bit	Description														
0	Group a/c														

Item	Byte	Command	Description									
			<table border="1"> <thead> <tr> <th>Bit</th> <th>Description</th> </tr> </thead> <tbody> <tr> <td>1</td> <td>Group b/d</td> </tr> <tr> <td>2-7</td> <td>000000</td> </tr> </tbody> </table> <p>Byte 2-5/6-9/10-13/14-17/18-21/22-25: Reactive Power. 6 channels with each channel reports: INT32, Unit: VAR</p>	Bit	Description	1	Group b/d	2-7	000000			
Bit	Description											
1	Group b/d											
2-7	000000											
Apparent Power (Group a+b)	1+25	0c	<p>Byte 1: For every bit: 1=Single-Phase, 0=Three-Phase</p> <table border="1"> <thead> <tr> <th>Bit</th> <th>Description</th> </tr> </thead> <tbody> <tr> <td>0</td> <td>Group a/c</td> </tr> <tr> <td>1</td> <td>Group b/d</td> </tr> <tr> <td>2-7</td> <td>000000</td> </tr> </tbody> </table> <p>Byte 2-5/6-9/10-13/14-17/18-21/22-25: Apparent Power. 6 channels with each channel reports: INT32, Unit: VA</p>		Bit	Description	0	Group a/c	1	Group b/d	2-7	000000
Bit	Description											
0	Group a/c											
1	Group b/d											
2-7	000000											
Apparent Power (Group c+d)	1+25	0d	<table border="1"> <thead> <tr> <th>Bit</th> <th>Description</th> </tr> </thead> <tbody> <tr> <td>0</td> <td>Group a/c</td> </tr> <tr> <td>1</td> <td>Group b/d</td> </tr> <tr> <td>2-7</td> <td>000000</td> </tr> </tbody> </table> <p>Byte 2-5/6-9/10-13/14-17/18-21/22-25: Apparent Power. 6 channels with each channel reports: INT32, Unit: VA</p>		Bit	Description	0	Group a/c	1	Group b/d	2-7	000000
Bit	Description											
0	Group a/c											
1	Group b/d											
2-7	000000											
Imported Active Energy (Group a+b)	1+25	0e	<p>Byte 1: For every bit: 1=Single-Phase, 0=Three-Phase</p> <table border="1"> <thead> <tr> <th>Bit</th> <th>Description</th> </tr> </thead> <tbody> <tr> <td>0</td> <td>Group a/c</td> </tr> <tr> <td>1</td> <td>Group b/d</td> </tr> <tr> <td>2-7</td> <td>000000</td> </tr> </tbody> </table> <p>Byte 2-5/6-9/10-13/14-17/18-21/22-25: Energy. 6 channels with each channel reports: UINT32, Unit: Wh</p>		Bit	Description	0	Group a/c	1	Group b/d	2-7	000000
Bit	Description											
0	Group a/c											
1	Group b/d											
2-7	000000											
Imported Active Energy (Group c+d)	1+25	0f	<table border="1"> <thead> <tr> <th>Bit</th> <th>Description</th> </tr> </thead> <tbody> <tr> <td>0</td> <td>Group a/c</td> </tr> <tr> <td>1</td> <td>Group b/d</td> </tr> <tr> <td>2-7</td> <td>000000</td> </tr> </tbody> </table> <p>Byte 2-5/6-9/10-13/14-17/18-21/22-25: Energy. 6 channels with each channel reports: UINT32, Unit: Wh</p>		Bit	Description	0	Group a/c	1	Group b/d	2-7	000000
Bit	Description											
0	Group a/c											
1	Group b/d											
2-7	000000											
Exported Active Energy (Group a+b)	1+25	10	<p>Byte 1: For every bit: 1=Single-Phase, 0=Three-Phase</p>									

Item	Byte	Command	Description	
Exported Active Energy (Group c+d)	1+25	11	Bit	Description
			0	Group a/c
			1	Group b/d
			2-7	000000
Byte 2-5/6-9/10-13/14-17/18-21/22-25: Energy. 6 channels with each channel reports: UINT32, Unit: Wh				
Imported Reactive Energy (Group a+b)	1+25	12	Byte 1: For every bit: 1=Single-Phrase, 0=Three-Phrase	
Imported Reactive Energy (Group c+d)	1+25	13	Bit	Description
			0	Group a/c
			1	Group b/d
			2-7	000000
Byte 2-5/6-9/10-13/14-17/18-21/22-25: Energy. 6 channels with each channel reports: UINT32, Unit: VARh				
Exported Reactive Energy (Group a+b)	1+25	14	Byte 1: For every bit: 1=Single-Phrase, 0=Three-Phrase	
Exported Reactive Energy (Group c+d)	1+25	15	Bit	Description
			0	Group a/c
			1	Group b/d
			2-7	000000
Byte 2-5/6-9/10-13/14-17/18-21/22-25: Energy. 6 channels with each channel reports: UINT32, Unit: VARh				
Apparent Energy (Group a+b)	1+25	16	Byte 1:	

Item	Byte	Command	Description								
Apparent Energy (Group c+d)	1+25	17	For every bit: 1=Single-Phrase, 0=Three-Phrase								
			<table border="1"> <thead> <tr> <th>Bit</th> <th>Description</th> </tr> </thead> <tbody> <tr> <td>0</td> <td>Group a/c</td> </tr> <tr> <td>1</td> <td>Group b/d</td> </tr> <tr> <td>2-7</td> <td>000000</td> </tr> </tbody> </table>	Bit	Description	0	Group a/c	1	Group b/d	2-7	000000
			Bit	Description							
			0	Group a/c							
1	Group b/d										
2-7	000000										
Byte 2-5/6-9/10-13/14-17/18-21/22-25: Energy. 6 channels with each channel reports: UINT32, Unit: VAh											

Example:

019d0a 022926 0c0008020000df0300008f000000a1000000b80000007e000000 0d0083050000b743010009010000cf010000450100002c000000	
Command	Value
01	Temperature: 9d0a=>0a9d=>2717/100=27.12°C
02	Voltage Three-Phase Unbalance: 2926=>2629=>9769/100=97.69%
0c	00=>00000000=All four groups are Three-Phrase. Apparent Power: 08020000 =>00000208=520W (Channel 1) df030000=>000003df=991W (Channel 2) 8f000000=>0000008f=>143W (Channel 3) a1000000=>000000a1==161W (Channel 4) b8000000=>000000b8=184W (Channel 5) 7e000000=>0000007e=126W (Channel 6)
0d	00=>00000000=All four groups are Three-Phrase. Apparent Power: 83050000=00000583=1411W (Channel 7) b7430100=000143b7=82871W (Channel 8) 09010000=>00000109=265W (Channel 9) cf010000=>000001cf=463W (Channel 10) 45010000=00000145=325W (Channel 11)

019d0a 022926 0c000802000df0300008f000000a1000000b8000007e000000 0d0083050000b743010009010000cf010000450100002c000000	
Command	Value
	2c000000=>0000002c=44W (Channel 12)

Monthly Data Packet

By default, the device is set to upload data for the previous month at midnight (00:00) on the first day of each month. The reporting schedule can be modified through a [downlink command](#).

Packet description:

Item	Byte	Command	Description
Monthly Energy	2+32	ed01	Timestamp(4B)+4001(2B)+Energy Data (26B) <ul style="list-style-type: none"> Energy Data include: Imported Active Energy/Exported Active Energy/Imported Reactive Energy/Exported Reactive Energy/Apparent Energy
Monthly Min. Value	2+6+N	ed01	Timestamp(4B)+4002(2B)+Periodic Data <ul style="list-style-type: none"> Periodic Data include: Temperature/Voltage Three-Phase Unbalance/Current /THDi/THDv/RMS Current/RMS Voltage/Power Factor/Active Power/Reactive Power/Apparent Power
Monthly Max. Value	2+6+N	ed01	Timestamp(4B)+4003(2B)+Periodic Data <ul style="list-style-type: none"> Periodic Data include: Temperature/Voltage Three-Phase Unbalance/Current /THDi/THDv/RMS Current/RMS Voltage/Power Factor/Active Power/Reactive Power/Apparent Power

Example:

ed0100277e69 4003 01 2e0b ed0100277e69 4003 02 1027 ed0100277e69 4003 03 d40e04057d23ff11081d46177c268309c4174916370e310a ed0100277e69 4003 04 000000000000 ed0100277e69 4003 06 5aa8fc81d331			
Command	Timestamp	Command	Value
ed01	00277e69 => 697e2700 = 1769875200s	4003	01=Temperature, 2e0b=0b2e=2862/100=28.62°C
			02= Voltage Three-Phase Unbalance, 1027=2710=10000/100=100%
			03=THDi, d40e=0ed4=3796/ 100=37.96% (Channel 1); 0405=0504=1284/ 100=12.84% (Channel 2); 7d23=237d=9085/ 100=90.85% (Channel 3); ff11=11ff=4607/100=46.07% (Channel 4); 081d=1d08=7432/ 100=74.32% (Channel 5); 4617=1746=5958/ 100=59.58% (Channel 6); 7c26=267c=9852/ 100=98.52% (Channel 7); 8309=0983=2435/ 100=24.35% (Channel 8); c417=17c4=6084/ 100=60.84% (Channel 9);

ed0100277e69 4003 01 2e0b			
ed0100277e69 4003 02 1027			
ed0100277e69 4003 03 d40e04057d23ff11081d46177c268309c4174916370e310a			
ed0100277e69 4003 04 000000000000			
ed0100277e69 4003 06 5aa8fc81d331			
Command	Timestamp	Command	Value
			4916=1649=5705/ 100=57.05% (Channel 10); 370e=0e37=3639/ 100=36.39% (Channel 11); 310a=0a31=2609/ 100=26.09% (Channel 12)
			04=THDv, 0000=0% (Channel 1); 0000=0% (Channel 2); 0000=0% (Channel 3)
			06=Voltage; 5aa8=a85a=43098/ 100=430.98 V (Channel 1); fc81=81fc=33276/ 100=33.276 V (Channel 2); d331=31d3=12755/ 100=12.755 V (Channel 3)

Alarm Report

The device reports the following types of alarm packets.

Packet description:

Item	Byte	Command	Description
<p>Temperature Threshold Alarm</p>	<p>1+3</p>	<p>30</p>	<p>Byte 1: Alarm Type</p> <p>00-Collect Error,</p> <p>03-No Data,</p> <p>10-Below threshold Alarm Dismiss, 11-Below threshold Alarm,</p> <p>12-Above threshold Alarm Dismiss, 13-Above threshold Alarm,</p> <p>14-Within-Threshold Alarm Dismiss, 15-Within-Threshold Alarm,</p> <p>16-Out-of-Threshold Alarm Dismiss, 17-Out-of-Threshold Alarm</p> <p>Byte 2-3: Temperature, INT16/100, Unit: °C, Range: -20 - 100</p>
<p>Current Threshold Alarm</p>	<p>1+5</p>	<p>31</p>	<p>Byte 1: Channel Number, Range: 0-11</p> <p>Byte 2: Alarm Type</p> <p>00-Collect Error,</p> <p>02-Above Range,</p> <p>04-Above Range Dismiss,</p> <p>10-Below threshold Alarm Dismiss, 11-Below threshold Alarm,</p> <p>12-Above threshold Alarm Dismiss, 13-Above threshold Alarm,</p> <p>14-Within-Threshold Alarm Dismiss, 15-Within-Threshold Alarm,</p>

Item	Byte	Command	Description
			16-Out-of-Threshold Alarm Dismiss, 17-Out-of-Threshold Alarm Byte 3-5: Current, UINT16/100, Unit: A
Voltage Threshold Alarm	1+4	32	Byte 1: Channel Number, Range: 0 - 2 Byte 2: Alarm Type 00-Collect Error, 02-Above Range, 04-Above Range Dismiss, 10-Below threshold Alarm Dismiss, 11-Below threshold Alarm, 12-Above threshold Alarm Dismiss, 13-Above threshold Alarm, 14-Within-Threshold Alarm Dismiss, 15-Within-Threshold Alarm, 16-Out-of-Threshold Alarm Dismiss, 17-Out-of-Threshold Alarm Byte 3-4: Voltage, UINT16/100, Unit: V
THDi Threshold Alarm	1+4	33	Byte 1: Channel Number, Range: 0 - 11 Byte 2: Alarm Type 00-Collect Error, 12-Above threshold Alarm Dismiss, 13-Above threshold Alarm, Byte 3-4: THDi, UINT16/100, Unit: %, Range: 0 - 100
THDv Threshold Alarm	1+4	34	Byte 1: Channel Number, Range: 0 - 2

Item	Byte	Command	Description
			Byte 2: Alarm Type 00-Collect Error, 13-Above threshold Alarm, Byte 3-4: THDv, UINT16/100, Unit: %, Range: 0 - 100
Voltage Three-Phase Unbalance Threshold Alarm	1+3	35	Byte 1: Alarm Type 00-Collect Error, 12-Above threshold Alarm Dismiss, 13-Above threshold Alarm, Byte 2-3: Voltage Three-Phase Unbalance, UINT16/100, Unit: %, Range: 0 - 100
Power Failure Alarm	1	36	-

Examples:

1. Power Failure Alarm: Report twice when the device's supply voltage drops from 12V to 0V.

36	
Command	Value
36	-

2. Temperature Alarm: Report when the conductor or busbar temperature reaches the threshold.

30139e0a	
Command	Value
30	13=Above threshold Alarm Temperature: 9e 0a => 0a 9e=2718/100=27.18°C

3. Current Overrange Alarm: Report when the current detected by the device exceeds the preset range.

3104023c28	
Command	Value
31	Channel Number: 04=Channel 5 Alarm Type: 02=Above Range Current: 3c28=>283c=>10300/100=103A

Historical Periodic Data

When [data retransmission](#) is triggered, the device will report a historical periodic report at data retransmission interval.

Packet description:

Item	Command	Report Mode	Timestamp	Historical Data
Periodic Report	ed	01	UINT32, Unit: s	Command + Periodic Report Data, see Data description 1
Monthly Report	ed	02	UINT32, Unit: s	Command + Monthly Report Data, see Data description 2

Example:

ed01a1b1856901360a				
Command	Report Mode	Timestamp	Command	Value
ed	01	a1b18569 => 6985b1a1 = 1770369441s	01	360a=>0a36=2614/ 100=26.14°C

ed0200277e69 4003 01 2e0b ed0200277e69 4003 02 1027 ed0200277e69 4003 03 d40e04057d23ff11081d46177c268309c4174916370e310a ed0200277e69 4003 04 000000000000 ed0200277e69 4003 06 5aa8fc81d331				
Com- mand	Report Mode	Timestamp	Command	Value
ed	01	00277e69 => 697e2700 = 1769875200s	4003	01=Temperature, 2e0b=0b2e=2862/100=28.62°C
				02= Voltage Three- Phase Unbalance, 1027=2710=10000/100=100%
				03=THDi, d40e=0ed4=3796/ 100=37.96% (Channel 1); 0405=0504=1284/ 100=12.84% (Channel 2); 7d23=237d=9085/ 100=90.85% (Channel 3); ff11=11ff=4607/100=46.07% (Channel 4); 081d=1d08=7432/ 100=74.32% (Channel 5); 4617=1746=5958/ 100=59.58% (Channel 6); 7c26=267c=9852/ 100=98.52% (Channel 7); 8309=0983=2435/ 100=24.35% (Channel 8);

ed0200277e69 4003 01 2e0b ed0200277e69 4003 02 1027 ed0200277e69 4003 03 d40e04057d23ff11081d46177c268309c4174916370e310a ed0200277e69 4003 04 000000000000 ed0200277e69 4003 06 5aa8fc81d331				
Com- mand	Report Mode	Timestamp	Command	Value
				c417=17c4=6084/ 100=60.84% (Channel 9); 4916=1649=5705/ 100=57.05% (Channel 10); 370e=0e37=3639/ 100=36.39% (Channel 11); 310a=0a31=2609/ 100=26.09% (Channel 12)
				04=THDv, 0000=0% (Channel 1); 0000=0% (Channel 2); 0000=0% (Channel 3)
				06=Voltage; 5aa8=a85a=43098/ 100=430.98V (Channel 1); fc81=81fc=33276/ 100=33.276 V (Channel 2); d331=31d3=12755/ 100=12.755 V (Channel 3)

Downlink Commands

Downlink commands can be used for remote control of device through a network server. The downlink port (application port) is 85 by default and can be configured through ToolBox.

If the device receives a downlink command requiring confirmation, it will send a reply packet in the following format:

Command (1B)	Result & Length (1B)	Command ID (1-N Byte)	...
ef	Bit 7-4: result code, 0=success, 5=parameter error, 7=execute error, 10=association error Bit 3-0: command length	Same as downlink command	...

For details of downlink commands please refer to the sections below.

Commands for General Settings

The device supports multiple commands for general settings.

Command description:

Item	Byte	Command	Description
Reporting Interval	1+3	61	Byte 1: 01 Byte 2-3: UUINT16, Unit: min, Range: 1-1440, Default: 10
Data Storage & Retransmission	1+2	c5	Byte 1: 00=Data storage, 01=Data retransmission Byte 2: 00=Disable, 01=Enable
Data Retransmission Interval	1+3	c5	Byte 1: 02 Byte 2-3: UUINT16, Unit:s, Range: 120-1200 s, Default: 600s
Data Retrieval Interval	1+3	c5	Byte 1: 03 Byte 2-3: UUINT16, Unit:s, Range: 120-1200 s, Default: 120s
Reboot	1	be	-
Bluetooth Name	1+14	64	Byte 1: Name Length, Range: 1 - 13 Byte 2-14: Bluetooth Name, ASCII

Item	Byte	Command	Description
Enquiry Periodic Report	1	b9	-
Rejoin the Network	1	b6	-
Clear Total Energy	1+1	5f	00=Clear All, 01=Clear Channel 1, 02=Clear Channel 2, ..., 12=Clear Channel 12
Clear History Data	1+1	5e	00=Alarm Data 01=Periodically Data 02=Monthly Energy Data 03=Monthly Max./Min. Data

Example:

1. Set report interval as 20 minutes.

61011400	
Command	Value
61	14 00=>00 14=20 minutes

2. Reboot the device.

be

3. Set Bluetooth Name as Milesight.

64094d696c657369676874	
Command	Value
64	Name Length: 09=9 Bluetooth Name: 4d696c657369676874=Milesight

Related information

[Configure General Parameters](#)

Commands for Time Settings

The device supports multiple commands for time setting.

Command description:

Item	Byte	Command	Description				
Daylight Saving Time	1+10	c6	<p>Byte 1: 00=Disable, 01=Enable</p> <p>Byte 2: DST bias, unit: min, range: 1-120</p> <p>Byte 3-6: Start time, Month (1B)+Week&Day (1B) + Minute Time (2B)</p> <p>Byte 7-10: End time, Month (1B)+Week&Day (1B) + Minute Time (2B)</p> <p>Week&Day:</p> <table border="1"> <thead> <tr> <th>Bit7-4</th> <th>Bit3-0</th> </tr> </thead> <tbody> <tr> <td>Week number, range: 1-5</td> <td>Weekday, range: 1-7</td> </tr> </tbody> </table>	Bit7-4	Bit3-0	Week number, range: 1-5	Weekday, range: 1-7
Bit7-4	Bit3-0						
Week number, range: 1-5	Weekday, range: 1-7						
Time Zone	1+2	c7	INT16/60				
Sync Time from LNS	1	b8	-				
Monthly Record Summary Time	1+3	6d	<p>Byte 1: Day, Range: 1-28</p> <p>Byte 2: Hour, Range: 0-23</p> <p>Byte 3: Minute, Range: 0-59</p>				

Example:

1. Set the time zone as UTC-4.

c710ff	
Command	Value
c7	10 ff => ff 10 = -240/60=-4

- Set DST time: start time is last Sunday 1:00 of March, end time is last Sunday 1:00 of October, and bias is 1h (60 minutes).

c6013c03573c000a573c00	
Command	Value
c6	01=Enable DST bias: 3c=>60 mins Start time: 03=>March, 57=>last (5) Sunday(7), 3c 00 =>00 3c=60 minutes =1:00 End time: 0a=>10=October, 57=>last (5) Sunday(7), 3c 00 =>00 3c=60 minutes =1:00

- Modify Monthly Record Summary Time as the 15th of each month at 9:00 AM.

6d0f0900	
Command	Value
6d	Day: 0f => 15 Hour: 09=9 Minute: 00

Related information

[Configure General Parameters](#)

Commands for Calibration Settings

The device supports multiple commands for calibration setting.

Command description:

Item	Byte	Command	Description
Temperature Calibration	1+3	6b	Byte 1: 00=Disable, 01=Enable Byte 2-3: Calibration value, INT16/100, range: -120 - 120, Unit: °C

Example:

1. Enable temperature calibration and set the calibration value.

6b01e2ff	
Command	Value
6b	01=Enable Calibration value: e2 ff=> ff e2 =-30/100=-0.3°C

Related information

[Configure Calibration Parameters](#)

Command for Threshold Settings

The device supports a command for threshold setting.

Command description:

Item	Byte	Com- mand	Description
Temperature Threshold	1+6	76	<p>Byte 1: 00=Disable, 01=Enable</p> <p>Byte 2: 00=Disable, 01=Below, 02=Above, 03=Within, 04=Below or above</p> <p>Byte 3-4: Min. threshold, INT16/100, range: -20-100, Unit: °C</p> <p>Byte 5-6: Max. threshold, INT16/100, range: -20-100, Unit: °C</p>
Current Threshold Alarm	2+6	770N	<p>N=Channel Number, Range: 0-b</p> <p>Byte 1: 00=Disable, 01=Enable</p> <p>Byte 2: 00=Disable, 01=Below, 02=Above, 03=Within, 04=Below or above</p> <p>Byte 3-4: Min. threshold, INT16. Unit: A</p> <p>Byte 5-6: Max. threshold, INT16. Unit: A</p>
Voltage Threshold Alarm	2+6	780N	<p>N=Channel Number, Range: 0-2</p> <p>Byte 1: 00=Disable, 01=Enable</p>

Item	Byte	Com- mand	Description
			<p>Byte 2: 00=Disable, 01=Below, 02=Above, 03=Within, 04=Below or above</p> <p>Byte 3-4: Min. threshold, INT16. Unit: V</p> <p>Byte 5-6: Max. threshold, INT16. Unit: V</p>
THDi Thresh- old Alarm	2+6	79	<p>N=Channel Number, Range: 0-b</p> <p>Byte 1: 00=Disable, 01=Enable</p> <p>Byte 2: 02=Above</p> <p>Byte 3-4: 0000</p> <p>Byte 5-6: Max. threshold, UINT16. Unit: %, Range: 1 - 100</p>
THDv Thresh- old Alarm	2+6	7a	<p>N=Channel Number, Range: 0-2</p> <p>Byte 1: 00=Disable, 01=Enable</p> <p>Byte 2: 02=Above</p> <p>Byte 3-4: 0000</p> <p>Byte 5-6: Max. threshold, UINT16. Unit: %, Range: 1 - 100</p>
Voltage Three- Phase Unbalance Threshold Alarm	1+6	7b	<p>Byte 1: 00=Disable, 01=Enable</p> <p>Byte 2: 02=Above</p> <p>Byte 3-4: 0000</p> <p>Byte 5-6: Max. threshold, UINT16. Unit: %, Range: 1 - 100</p>
Global Alarm Settings	1+5	7c	<p>Byte 1-2: Alarm Reporting Interval, UINT16, Unit: min, Range: 1 - 1440</p> <p>Byte 3-4: Alarm Reporting Times, UINT16, Range: 1 - 1000</p> <p>Byte 5: Dismiss Report, 00=Disable, 01=Enable</p>

Example:

1. Enable the temperature threshold alarm and set the alarm threshold as over 25°C.

7601020000c409	
Command	Value
76	01=Enable, 02=Above Max. threshold: c4 09 => 09 c4 => 2500/100 = 25°C

2. Set the threshold of current channel 5 to a value greater than 888A; and set the threshold of current channel 9 to a value between 1A and 300A; and set the threshold of current channel 11 greater than 666A or less than 222A.

7704010200007803 7708010301002c01 770a0104de009a02	
Command	Value
7704	04=>Channel 5 01=Enable 02=Above Min. threshold=0000=0A Max. threshold=7803=0378=888A
7708	08=Channel 9 01=Enable 03=Within Min. threshold=0100=0001=1A Max. threshold=2c01=012c= 300A
770a	0a=Channel 11 01=Enable 04=Below or above Min. threshold=de00=00de=222A Max. threshold=9a02=029a=666A

3. Set Alarm reporting interval as 10 minutes and times as 2.

7c0a00020000	
Command	Value
7c	Alarm Reporting Interval: 0a00=>000a=10min Alarm Reporting Times: 0200=>0002=2 Dismiss Report: 00=Disable

Related information

[Configure Threshold Parameters](#)

Command for Report Parameters

The device supports multiple commands for report parameters.

Command description:

Item	Byte	Command	Description																								
Report Parameters	1+2	6c	For every bit: 0=Disable, 1=Enable																								
			<table border="1"> <thead> <tr> <th>Bit</th> <th>Description</th> </tr> </thead> <tbody> <tr> <td>0</td> <td>Temperature</td> </tr> <tr> <td>1</td> <td>RMS Current</td> </tr> <tr> <td>2</td> <td>RMS Voltage</td> </tr> <tr> <td>3</td> <td>Power Factor</td> </tr> <tr> <td>4</td> <td>Active Power</td> </tr> <tr> <td>5</td> <td>Reactive Power</td> </tr> <tr> <td>6</td> <td>Apparent Power</td> </tr> <tr> <td>7</td> <td>Imported Active Energy</td> </tr> <tr> <td>8</td> <td>Exported Active Energy</td> </tr> <tr> <td>9</td> <td>Imported Reactive Energy</td> </tr> <tr> <td>10</td> <td>Exported Reactive Energy</td> </tr> </tbody> </table>	Bit	Description	0	Temperature	1	RMS Current	2	RMS Voltage	3	Power Factor	4	Active Power	5	Reactive Power	6	Apparent Power	7	Imported Active Energy	8	Exported Active Energy	9	Imported Reactive Energy	10	Exported Reactive Energy
			Bit	Description																							
			0	Temperature																							
			1	RMS Current																							
			2	RMS Voltage																							
			3	Power Factor																							
			4	Active Power																							
			5	Reactive Power																							
			6	Apparent Power																							
			7	Imported Active Energy																							
			8	Exported Active Energy																							
9	Imported Reactive Energy																										
10	Exported Reactive Energy																										

Item	Byte	Command	Description												
			<table border="1"> <thead> <tr> <th>Bit</th> <th>Description</th> </tr> </thead> <tbody> <tr> <td>11</td> <td>Apparent Energy</td> </tr> <tr> <td>12</td> <td>Current Total Harmonic Distortion (THDi)</td> </tr> <tr> <td>13</td> <td>Voltage Total Harmonic Distortion (THDv)</td> </tr> <tr> <td>14</td> <td>Voltage Three-Phase Unbalance</td> </tr> <tr> <td>15</td> <td>0</td> </tr> </tbody> </table>	Bit	Description	11	Apparent Energy	12	Current Total Harmonic Distortion (THDi)	13	Voltage Total Harmonic Distortion (THDv)	14	Voltage Three-Phase Unbalance	15	0
Bit	Description														
11	Apparent Energy														
12	Current Total Harmonic Distortion (THDi)														
13	Voltage Total Harmonic Distortion (THDv)														
14	Voltage Three-Phase Unbalance														
15	0														
Current Interface (Group a)	1+10	67	Type (1B)+Current Direction-CH1(1B)+Range-CH1(2B)+Current Direction-CH2(1B)+Range-CH2(2B)+...+Current Direction-CH12(1B)+Range-CH12(2B)												
Current Interface (Group b)	1+10	68	Byte 1: Type, 00=Single-Phrase, 01=Three-Phrase												
Current Interface (Group c)	1+10	69	Byte 2/5/8: Current Direction, 00=Forward, 01=Reverse												
Current Interface (Group d)	1+10	6a	Byte 3-4/6-7/9-10: Range, Unit: A, 0000=None, 0001=100A, 0002=300A, 0003=500A, 0004=1000A, 0005=4000A												
Voltage Interface	1+1	66	00=Single-Phrase, 01=Three-Phrase												

Example:

1. Set Current Interface (Group b) Range: Three-Phrase, Channel 4=Reverse 1000A; Channel 5=Reverse 300A; Channel 6=Forward 100A.

6801010400010200000100	
Command	Parameter
68	01=Three-Phrase Channel 4: Current Direction: 01=Reverse; Range: 0400=0004=>1000A Channel 5: Current Direction: 01=Reverse; Range: 0200=0002=>300A Channel 6: Current Direction: 00=Forward; Range: 0100=0001=>100A

2. Set Current Interface (Group c) Range: Single-Phrase, Channel 8=Reverse 100A.

6900010000010100010000	
Command	Parameter
69	00=Single-Phrase Channel 7: Current Direction: 01=Reverse; Range: 0000=0000=>None Channel 8: Current Direction: 01=Reverse; Range: 0100=0001=>100A Channel 9: Current Direction: 01=Reverse; Range: 0000=0000=>None

Related information

[Configure Interface Parameters](#)

[Configure Report Parameters](#)

Commands for Configuration Query

The device supports multiple commands for querying its configuration.

Command format:

Item	Byte	Command	Data
Report Interval	1	b9	-
Threshold Configuration	1+1	58	00=Temperature 01=Current 02=Voltage 03=THDi 04=THDv 05=Voltage Three-Phase Unbalance

Example:

1. Enquire the configuration of reporting interval.

b9	
Command	Value
b9	-

Reply:

61010a00	
Command	Value
61	Interval time: 0a00=000a=10min

2. Enquire the configuration of temperature threshold.

5800	
Command	Value
58	00=Temperature Threshold

Reply:

760103e803b80b	
Command	Value
76	01=Enable temperature threshold 03=Within Min. threshold: e803=>03e8=1000/100=10°C Max. threshold: b80b=>0bb8=3000/100=30°C

Commands for Historical Data Query

The device can query historical data for a specified time point or range through downlink commands. The specified time point can use [Unix Timestamp Converter](#) to calculate. The prerequisites are that the device time is correct and the **data storage function** is enabled. The device uploads a maximum of 300 data records per range query.

When querying data for a specific time point, the device uploads the record closest to the requested time within the current reporting interval. For example, with a 10-minute reporting interval, a query for 17:00

will return the exact record if it exists. Otherwise, the device searches for data within a tolerance of ± 10 minutes (16:50 to 17:10) and uploads the record closest to 17:00.

Command Format:

Item	Byte	Command	Description
Query data for a specified time point	1+5	5b	<p>Byte 1:</p> <ul style="list-style-type: none"> • 00=Alarm Data • 01=Periodically Data • 02=Monthly Energy Data • 03=Monthly Max./Min. Data <p>Byte 2-5: Unix timestamp</p>
Query data for a specified time range	1+9	5c	<p>Byte 1:</p> <ul style="list-style-type: none"> • 00=Alarm Data • 01=Periodically Data • 02=Monthly Energy Data • 03=Monthly Max./Min. Data <p>Byte 2-5: Start time, Unix timestamp</p> <p>Byte 6-9: End time, Unix timestamp</p>
Stop data query report	1+1	5d	<p>00=Alarm Data</p> <p>01=Periodically Data</p> <p>02=Monthly Energy Data</p> <p>03=Monthly Max./Min. Data</p>
Clear History Data	1+1	5e	<p>00=Alarm Data</p> <p>01=Periodically Data</p> <p>02=Monthly Energy Data</p> <p>03=Monthly Max./Min. Data</p>

Reply format:

Item	Command	Report Mode	Timestamp	Historical Data
Periodic Report	ed	01	UINT32, Unit: s	Command + Periodic Report Data, see Data description 1
Monthly Report	ed	02	UINT32, Unit: s	Command + Monthly Report Data, see Data description 2

Example:

Enquire the historical data in a time range.

5c0100847b6980048a69	
Command	Value
5c	01=Periodically Data Start time: 00 84 7b 69 => 69 7b 84 00 = 1769702400s End time: 80 04 8a 69 => 69 8a 04 80 = 1770652800s

Reply:

ed01a1b1856901360a				
Command	Report Mode	Timestamp	Command	Value
ed	01	a1b18569 => 6985b1a1 = 1770369441s	01	360a=>0a36=2614/ 100=26.14°C

ed0200277e69 4003 01 2e0b ed0200277e69 4003 02 1027 ed0200277e69 4003 03 d40e04057d23ff11081d46177c268309c4174916370e310a ed0200277e69 4003 04 000000000000 ed0200277e69 4003 06 5aa8fc81d331				
Com- mand	Report Mode	Timestamp	Command	Value
ed	01	00277e69 => 697e2700 = 1769875200s	4003	01=Temperature, 2e0b=0b2e=2862/100=28.62°C
				02= Voltage Three- Phase Unbalance, 1027=2710=10000/100=100%
				03=THDi, d40e=0ed4=3796/ 100=37.96% (Channel 1); 0405=0504=1284/ 100=12.84% (Channel 2); 7d23=237d=9085/ 100=90.85% (Channel 3); ff11=11ff=4607/100=46.07% (Channel 4); 081d=1d08=7432/ 100=74.32% (Channel 5); 4617=1746=5958/ 100=59.58% (Channel 6); 7c26=267c=9852/ 100=98.52% (Channel 7); 8309=0983=2435/ 100=24.35% (Channel 8);

ed0200277e69 4003 01 2e0b ed0200277e69 4003 02 1027 ed0200277e69 4003 03 d40e04057d23ff11081d46177c268309c4174916370e310a ed0200277e69 4003 04 000000000000 ed0200277e69 4003 06 5aa8fc81d331				
Com- mand	Report Mode	Timestamp	Command	Value
				c417=17c4=6084/ 100=60.84% (Channel 9); 4916=1649=5705/ 100=57.05% (Channel 10); 370e=0e37=3639/ 100=36.39% (Channel 11); 310a=0a31=2609/ 100=26.09% (Channel 12)
				04=THDv, 0000=0% (Channel 1); 0000=0% (Channel 2); 0000=0% (Channel 3)
				06=Voltage; 5aa8=a85a=43098/ 100=430.98V (Channel 1); fc81=81fc=33276/ 100=33.276 V (Channel 2); d331=31d3=12755/ 100=12.755 V (Channel 3)

Related information

[Configure Data Storage & Retransmission](#)

Chapter 6. Services

Milesight provides customers with timely and comprehensive technical support services. End-users can contact their local dealer to obtain technical support. Distributors and resellers can contact Milesight directly for technical support.

Technical Support Mailbox: iot.support@milesight.com

Online Support Portal: <https://support.milesight-iot.com>

Resource Download Center: <https://www.milesight.com/iot/resources/download-center/>

MILESIGHT CHINA

TEL: +86-592-5085280

FAX: +86-592-5023065

Add: Building C09, Software Park Phase III, Xiamen 361024, Fujian, China