

## Safety Function: Magnetic Door Switch Monitoring

Products: MC1 Magnetically-coded Door Switch,  
Guardmaster Dual-input Safety Relay  
Safety Rating: CAT. 3, PLd to EN ISO 13849-1: 2008

LISTEN.  
THINK.  
SOLVE.

## Important User Information

Read this document and the documents listed in the additional resources section about installation, configuration, and operation of this equipment before you install, configure, operate, or maintain this product. Users are required to familiarize themselves with installation and wiring instructions in addition to requirements of all applicable codes, laws, and standards.

Activities including installation, adjustments, putting into service, use, assembly, disassembly, and maintenance are required to be carried out by suitably trained personnel in accordance with applicable code of practice.

If this equipment is used in a manner not specified by the manufacturer, the protection provided by the equipment may be impaired.



In no event will Rockwell Automation, Inc. be responsible or liable for indirect or consequential damages resulting from the use or application of this equipment.

The examples and diagrams in this manual are included solely for illustrative purposes. Because of the many variables and requirements associated with any particular installation, Rockwell Automation, Inc. cannot assume responsibility or liability for actual use based on the examples and diagrams.



No patent liability is assumed by Rockwell Automation, Inc. with respect to use of information, circuits, equipment, or software described in this manual.

Reproduction of the contents of this manual, in whole or in part, without written permission of Rockwell Automation, Inc., is prohibited.

Throughout this manual, when necessary, we use notes to make you aware of safety considerations.

	<b>WARNING:</b> Identifies information about practices or circumstances that can cause an explosion in a hazardous environment, which may lead to personal injury or death, property damage, or economic loss.
	<b>ATTENTION:</b> Identifies information about practices or circumstances that can lead to personal injury or death, property damage, or economic loss. Attentions help you identify a hazard, avoid a hazard, and recognize the consequence.
<b>IMPORTANT</b>	Identifies information that is critical for successful application and understanding of the product.

Labels may also be on or inside the equipment to provide specific precautions.

	<b>SHOCK HAZARD:</b> Labels may be on or inside the equipment, for example, a drive or motor, to alert people that dangerous voltage may be present.
	<b>BURN HAZARD:</b> Labels may be on or inside the equipment, for example, a drive or motor, to alert people that surfaces may reach dangerous temperatures.



**ARC FLASH HAZARD:** Labels may be on or inside the equipment, for example, a motor control center, to alert people to potential Arc Flash. Arc Flash will cause severe injury or death. Wear proper Personal Protective Equipment (PPE). Follow ALL Regulatory requirements for safe work practices and for Personal Protective Equipment (PPE).

## General Safety Information

Contact Rockwell Automation to find out more about our safety risk assessment services.

<b>IMPORTANT</b>	This application example is for advanced users and assumes that you are trained and experienced in safety system requirements.
	<b>ATTENTION:</b> Perform a risk assessment to make sure all task and hazard combinations have been identified and addressed. The risk assessment can require additional circuitry to reduce the risk to a tolerable level. Safety circuits must take into consideration safety distance calculations, which are not part of the scope of this document.

## Table of Contents

Important User Information .....	2
General Safety Information .....	3
Introduction .....	3
Safety Function Realization: Risk Assessment .....	4
Magnetic-coded Door Interlock Switch Safety Function .....	4
Safety Function Requirements .....	4
Functional Safety Description .....	5
Bill of Material .....	5
Setup and Wiring .....	6
Configuration .....	8
Calculation of the Performance Level.....	9
Verification and Validation Plan.....	13
Additional Resources .....	18

## Introduction

This safety function application technique explains how to wire and configure an MC1 magnetically-coded interlock switch and an E-stop as input devices, a Guardmaster® dual-input safety relay as the logic control, and two 100S safety contactors as the output devices to create an integrated safety system.

## Safety Function Realization: Risk Assessment

The required performance level is the result of a risk assessment and refers to the amount of the risk reduction to be carried out by the safety-related parts of the control system. Part of the risk reduction process is to determine the safety functions of the machine. In this application, the performance level required (PLr) by the risk assessment is Category 3, Performance Level d (CAT. 3, PLd), for each safety function. A safety system that achieves CAT. 3, PLd, or higher, can be considered control reliable. Each safety product has its own rating and can be combined to create a safety function that meets or exceeds the PLr.

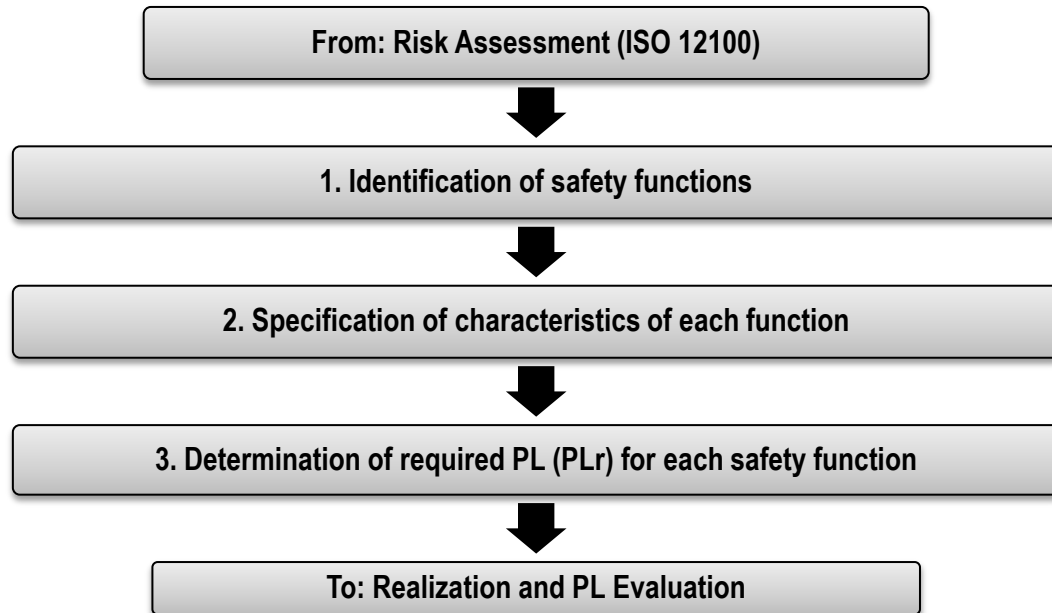

## Magnetic-coded Door Interlock Switch Safety Function

This safety function application provides two safety functions:

- A door monitoring function: the removal of power from the hazard when the safety system detects that the door has been opened.
- An E-stop function: the removal of power from the hazard when the safety system detects that the E-stop has been actuated.

## Safety Function Requirements

The opening of a guard door stops and prevents hazardous motion by removing power to the motor. When the door is closed, hazardous motion and power to the motor does not resume until a secondary action occurs—the Reset button is pressed and released. Pressing the E-stop button stops and prevents hazardous motion by removing power to the motor. The motor coasts to a stop (Stop Category 0). When the E-stop is released, hazardous motion and power to the motor do not resume until a secondary action occurs—the Reset button is pressed and released. A fault at the door interlock switch, wiring terminals, or safety controller is detected before the next safety demand. The safety functions in this example are capable of connecting and interrupting power to motors rated up to 9 A, 600V AC. The safety functions in this application technique each meet or exceed the requirements for Category 3,

Performance Level d (CAT. 3, PLd), per EN ISO 13849-1 and control reliable operation per ANSI B11.19.

## Functional Safety Description

### Door Monitoring Function

When the door is opened, the MC1 magnetically-coded switch opens its two N.C. reed switches. The Guardmaster dual-input safety relay responds to the MC1 outputs by turning off its safety contacts (13...14 and 23...24), de-energizing the coils of K1 and K2. With the power removed, hazardous motion coasts to a stop (Stop Category 0). Hazardous motion cannot be started until the door is closed and the Reset button is pressed and released.

### E-stop Function

The pulsed outputs of the relay (terminals S11 and S21) are run separately through the two E-stop contacts to the input terminals (S12 and S22), respectively. When the E-stop button is pressed, the two circuits are interrupted. The relay responds to this circuit interruption by opening its safety contacts (13...14 and 23...24), de-energizing the coils of K1 and K2. With the power removed, hazardous motion coasts to a stop (Stop Category 0). Hazardous motion cannot be started until the E-stop button is released and the Reset button is pressed and released.

## Bill of Material

This application uses these products.

Cat. No.	Description	Quantity
440N-Z2NRS1C	MC1 magnetically-coded safety interlock switch	1
800FM-G611MX10	800F reset push button - metal, guarded, blue, R, metal latch mount, 1 N.O. contact, standard	1
100S-C09ZJ23C	Bulletin 100S-C - safety contactors	2
800F-1YP3	800F 1-hole enclosure E-stop station, plastic, PG, twist-to-release 40 mm, non-illuminated, 2 N.C. contacts	1
440R-D22R2	Guardmaster dual-input safety relay, 2 dual-channel universal inputs, 1 N.C. contact, solid-state auxiliary output	1

## Setup and Wiring

For detailed information on installing and wiring, refer to the product manuals listed in the [Additional Resources](#).

### System Overview

The MC1 magnetically-coded door switch has two N.C. reed switches. Pulsed outputs terminals (S11 and S21) are run through these N.C. contacts to input terminals (S32 and S42, respectively). This enables the relay to detect loose wires, wires shorted to 24V DC, wires shorted to GND, and cross-channel faults.

The pulsed outputs of the relay (terminals S11 and S21) are run separately through the two E-stop contacts to the input terminals (S12 and S22), respectively. This enables the relay to detect loose wires, contact failed closed, shorts to 24V DC, shorts to GND, and cross channel faults. The relay responds to faults by opening its safety contacts (13...14 and 23...24), de-energizing the coils of K1 and K2. The relay cannot be reset until the fault is removed. In some cases, the E-stop must be pressed and released before the relay can be reset. The relay must be power-cycled once the fault is cleared before it can be reset.

The relay monitors itself for any internal faults. When a fault is detected, the relay responds by opening its safety contacts (13...14 and 23...24), de-energizing the coils of K1 and K2. Some internal faults can be cleared by power-cycling the relay. In other cases, the relay must be replaced.

The relay monitors the 100S contactors for welded contacts via two N.C. contacts in series, one from each 100S, in its reset circuit. If a contact of a 100S is welded, the N.C. contact is held open, breaking the reset circuit.



## Configuration

The following procedure sets the function of the device.

1. To start configuration/overwrite: with the power off, turn the rotary switch to position 0.  
The unit powers up. After the power-up test, the PWD status indicator flashes red.
2. To set the configuration, turn the rotary switch to position 2.  
The IN 1 status indicator blinks for the new setting.  
Position is set when the PWR status indicator is solid green.
3. Lock-in the configuration by cycling unit power.
4. Confirm the configuration before operation.
5. Record the unit setting in the white space on the face of the device.

**LOGIC 2 = L12 or (IN1 and IN2)**

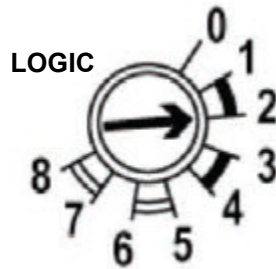

## Calculation of the Performance Level

When configured correctly, the safety functions of this safety system provide a method of isolation by the use of two safety contactors. When properly implemented, these safety functions can achieve a safety rating of Category 3, Performance Level d (Cat. 3, PLd), according to EN ISO 13849-1: 2008, as calculated by using the SISTEMA software PL calculation tool. Calculations are based on the safety function being operated once an hour, 24 hours a day, 365 days a year for a total of 8760 operations per year. The 100S contactors are used in the safety function, therefore, their calculations are based on 17,520 operations per year.

### Overall Safety Function Data for the Magnetic Switch and E-stop Safety Function with GSR Relays

The screenshot shows the SISTEMA software interface with a table of safety functions. The table has columns for Status, Type, Name, Type, PLr, and PL. Two entries are visible: 'Magnetic Door Switch Safety Function' and 'Emergency Stop Safety Function'.

Status	Type	Name	Type	PLr	PL
✓	SF	Magnetic Door Switch Safety Function		d	d
✓	SF	Emergency Stop Safety Function		d	e

The MC1 magnetically-coded door switch safety function can be modeled as follows.

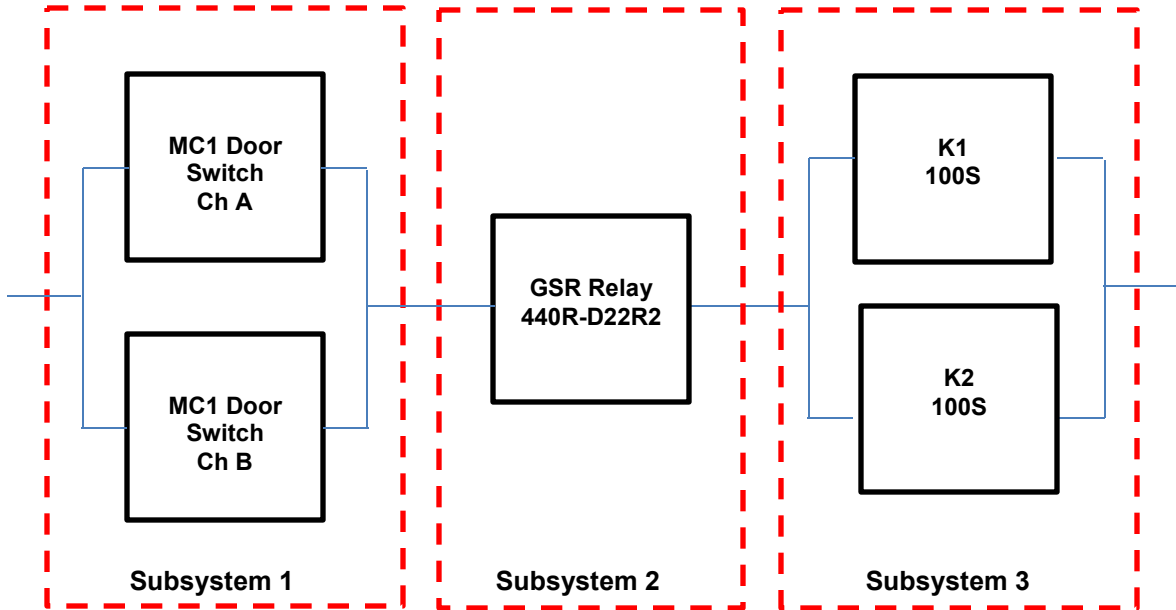

**Door Switch Safety Function Data**

The screenshot shows the SIMATIC Manager interface with the 'Safety function' window open. It displays a table of subsystem data. The table has columns for Status, Type, Name, PL, PFH [1/h], CCF score, DCavg [%], MTTFd [a], Category, and Requirements of the category. Three subsystems are listed, all with a status of 'fulfilled'.

Status	Type	Name	PL	PFH [1/h]	CCF score	DCavg [%]	MTTFd [a]	Category	Requirements of the category
✓	SB	Interlock Switch: Magnetically Coded: Default Data	d	3.54E-7	90 (fulfilled)	99 (High)	10 (Medium)	3	fulfilled
✓	SB	Monitoring Safety Relay: GSR-DI	e	4.35E-9	not relevant	not relevant	not relevant	4	fulfilled
✓	SB	100S Contactors	e	2.47E-8	65 (fulfilled)	99 (High)	100 (High)	4	fulfilled

**Door Switch Safety Function Subsystem 1**

SB Interlock Switch: Magnetically Coded: Default Data	
PL	d
PFH [1/h]	3.54E-7
Cat.	3
MTTFd [a]	10 (Medium)
DCavg [%]	99 (High)
CCF	90 (fulfilled)

**Door Switch Safety Function Subsystem 2**

SB Monitoring Safety Relay: GSR-DI	
PL	e
PFH [1/...]	4.35E-9
Cat.	4
MTTFd ...	not relevant
DCavg ...	not relevant
CCF	not relevant

**Door Switch Safety Function Subsystem 3**

SB 100S Contactors	
PL	e
PFH [1/...]	2.47E-8
Cat.	4
MTTFd ...	100 (High)
DCavg ...	99 (High)
CCF	65 (fulfilled)

The E-stop safety function can be modeled as follows.

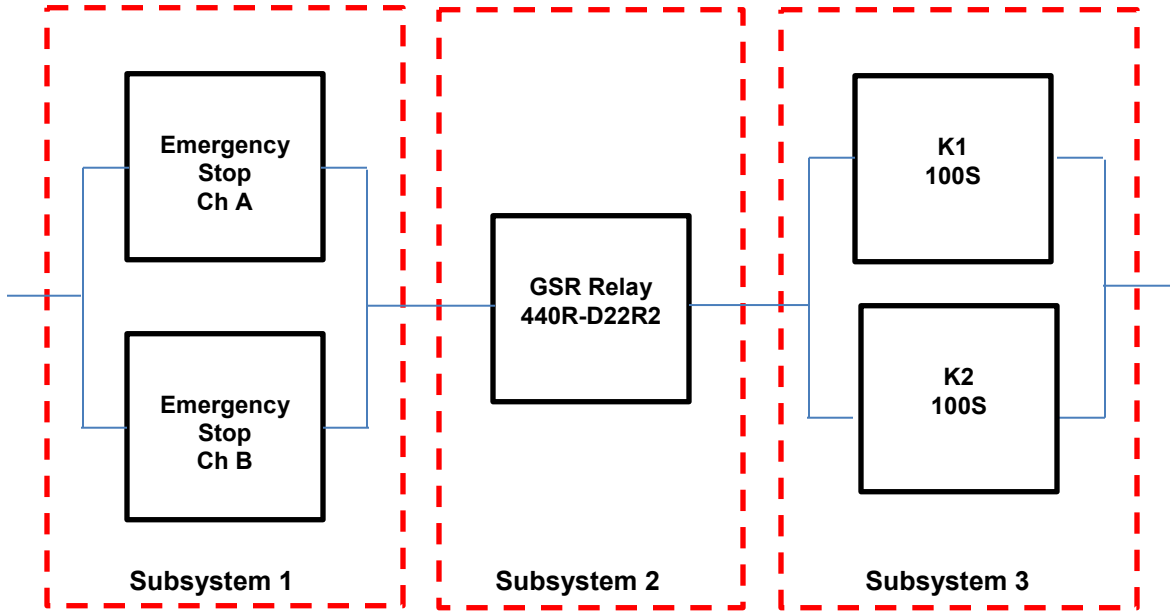

Emergency Stop Safety Function Data

Safety function IFA

Status	Type	Name	PL	PFH [1/h]	CCF score	DCavg [%]	MTTFd [a]	Category	Requirements of the category
✓	SB	E-Stop	e	2.47E-8	90 (fulfilled)	99 (High)	100 (High)	4	fulfilled
✓	SB	Monitoring Safety Relay: GSR-DI	e	4.35E-9	not relevant	not relevant	not relevant	4	fulfilled
✓	SB	100S Contactors	e	2.47E-8	65 (fulfilled)	99 (High)	100 (High)	4	fulfilled

Emergency Stop Safety Function Subsystem 1

<b>SB E-Stop</b>	
PL	e
PFH [1/...	2.47E-8
Cat.	4
MTTFd ...	100 (High)
DCavg ...	99 (High)
CCF	90 (fulfilled)

Emergency Stop Safety Function Subsystem 2

<b>SB Monitoring Safety Relay: GSR-DI</b>	
PL	e
PFH [1/...	4.35E-9
Cat.	4
MTTFd ...	not relevant
DCavg ...	not relevant
CCF	not relevant

**Emergency Stop Safety Function Subsystem 3**

SE 100S Contactors	
PL	e
PFH [1/...	2.47E-8
Cat.	4
MTTFd ...	100 (High)
DCavg ...	99 (High)
CCF	65 (fulfilled)

Because these are electro-mechanical devices, the E-stop and safety contactors data includes the following:

- Mean Time to Failure, dangerous (MTTFd)
- Diagnostic Coverage (DCavg)
- Common Cause Failure (CCF)

Electro-mechanical devices' functional safety evaluations include the following:

- How frequently they are operated
- Whether they are effectively monitored for faults
- Whether they are properly specified and installed

SISTEMA software calculates the MTTFd by using B10d data provided for the contactors along with the estimated frequency of use, entered during the creation of the SISTEMA project.

The DCavg (99%) for the contactors is selected from the Output Device table of EN ISO 13849-1 Annex E, Direct Monitoring.

The DCavg (99%) for the E-stop is selected from the Input Device table of EN ISO 13849-1 Annex E, Cross Monitoring.

The CCF value is generated by using the scoring process outlined in Annex F of EN ISO 13849-1. The complete CCF scoring process must be performed when actually implementing an application. A minimum score of 65 must be achieved.

## Verification and Validation Plan

Verification and validation play important roles in the avoidance of faults throughout the safety system design and development process. EN ISO 13849-2 sets the requirements for verification and validation. The standard calls for a documented plan to confirm all of the safety functional requirements have been met.

Verification is an analysis of the resulting safety control system. The Performance Level (PL) of the safety control system is calculated to confirm that the system meets the required Performance Level (PLr) specified. The SISTEMA software is typically used to perform the calculations and assist with satisfying the requirements of EN ISO 13849-1.

Validation is a functional test of the safety control system to demonstrate that the system meets the specified requirements of the safety function. The safety control system is tested to confirm that all of the safety-related outputs respond appropriately to their corresponding safety-related inputs. The functional test includes normal operating conditions in addition to potential fault inject of failure modes. A checklist is typically used to document the validation of the safety control system.

*Prior to validating the Guardmaster safety relay (GSR) system, confirm that the Guardmaster safety relay has been wired and configured in accordance with the installation instructions.*

**GSR Magnetic Switch Safety Function Verification and Validation Checklist**

General Machinery Information	
Machine Name/Model Number	
Machine Serial Number	
Customer Name	
Test Date	
Tester Name(s)	
Schematic Drawing Number	
Guardmaster Safety Relay Model	

Safety Wiring and Relay Configuration Verification			
Test Step	Verification	Pass/Fail	Changes/Modification
	Visually inspect the safety relay circuit to verify that the safety relay circuit is wired as documented in the schematics.		
	Visually inspect the safety relay rotary switch settings to verify they are correct as documented.		

Normal Operation Verification			
The safety relay system properly responds to all normal Start, Stop, E-stop, and Reset commands.			
Test Step	Verification	Pass/Fail	Changes/Modification
	Initiate a Start command. Both contactors energize for a normal machine run condition. Verify proper machine-status indication and safety-relay status indication.		
	Initiate a Stop command. Both contactors de-energize for a normal machine Stop condition. Verify proper machine-status and safety-relay status indication.		
	While the system is running, open the monitored guard door. Both contactors de-energize and open for a normal safe condition. Verify proper machine-status indication and safety-relay status indication. Repeat for all guard doors.		
	While the system is stopped with the guard door open, initiate a Start command. Both contactors remain de-energized and open for a normal safe condition. Verify proper machine-status indication and safety-relay status indication. Repeat for all door locks.		
	Initiate a Reset command. Both contactors remain de-energized. Verify proper machine-status indication and safety-relay status indication.		

**GSR Magnetic Switch Safety Function Verification and Validation Checklist (continued)**

**Abnormal Operation Validation**

The safety relay system properly responds to all foreseeable faults with corresponding diagnostics.

**Door Monitoring Input Tests**

Test Step	Validation	Pass/Fail	Changes/Modification
	While the system is running, remove the channel 1 wire from the safety relay. Both contactors de-energize. Verify proper machine-status indication and safety-relay status indication. Repeat for channel 2.		
	While the system is running, short channel 1 of the safety relay to 24V DC. Both contactors de-energize. Verify proper machine-status indication and safety-relay status indication. Repeat for channel 2.		
	While the system is running, short channel 1 of the safety relay to 0V DC. Both contactors de-energize. Verify proper machine-status indication and safety-relay status indication. Repeat for channel 2.		
	While the system is running, short channels 1 and 2 of the safety relay. Both contactors de-energize. Verify proper machine-status indication and safety-relay status indication.		

**GSR Logic Solver Tests**

Test Step	Verification and Validation	Pass/Fail	Changes/Modification
	While the system is running, remove the single wire safety connection between two adjoining safety relays in the system. All contactors de-energize. Verify proper machine-status indication and safety-relay status indication. Repeat for all safety connections. This test is not applicable for single relay circuits.		
	While the system is running, turn the logic rotary switch on the safety relay. All contactors remain energized. Verify proper machine-status indication and safety-relay status indication. Repeat for all safety relays in the system.		

**Safety Contactor Output Tests**

Test Step	Validation	Pass/Fail	Changes/Modification
	While the system is running, remove the contactor feedback from the safety relay. All contactors remain energized. Initiate a Stop command followed by a Reset command. The relay does not restart or reset. Verify proper machine-status indication and safety-relay status indication.		

**GSR Magnetic Switch Safety Function Verification and Validation Checklist (continued)**

<b>General Machinery Information</b>			
Machine Name/Model Number			
Machine Serial Number			
Customer Name			
Test Date			
Tester Name(s)			
Schematic Drawing Number			
Guardmaster Safety Relay Model			
<b>Safety Wiring and Relay Configuration Verification</b>			
<b>Test Step</b>	<b>Verification</b>	<b>Pass/Fail</b>	<b>Changes/Modification</b>
	Visually inspect the safety relay circuit to verify that the safety relay circuit is wired as documented in the schematics.		
	Visually inspect the safety relay rotary switch settings to verify they are correct as documented.		
<b>Normal Operation Verification</b>			
<b>The safety relay system properly responds to all normal Start, Stop, E-stop, and Reset commands.</b>			
<b>Test Step</b>	<b>Verification</b>	<b>Pass/Fail</b>	<b>Changes/Modification</b>
	Initiate a Start command. Both contactors energize for a normal machine run condition. Verify proper machine-status indication and safety-relay status indication.		
	Initiate a Stop command. Both contactors de-energize for a normal machine Stop condition. Verify proper machine-status and safety-relay status indication.		
	While the system is running, press the E-stop button. Both contactors de-energize and open for a normal safe condition. Verify proper machine-status indication and safety-relay status indication. Repeat for all E-stop buttons.		
	While the system is stopped, press the E-stop button and initiate a Start command. Both contactors remain de-energized and open for a normal safe condition. Verify proper machine-status indication and safety-relay status indication. Repeat for all E-stop buttons.		
	Initiate a Reset command. Both contactors remain de-energized. Verify proper machine-status indication and safety-relay status indication.		

**GSR Emergency Stop Safety Function Verification and Validation Checklist (continued)**

**Abnormal Operation Validation**

The safety relay system properly responds to all foreseeable faults with corresponding diagnostics.

**E-stop Input Tests**

Test Step	Validation	Pass/Fail	Changes/Modification
	While the system is running, remove the channel 1 wire from the safety relay. Both contactors de-energize. Verify proper machine-status indication and safety-relay status indication. Repeat for channel 2.		
	While the system is running, short channel 1 of the safety relay to 24V DC. Both contactors de-energize. Verify proper machine-status indication and safety-relay status indication. Repeat for channel 2.		
	While the system is running, short channel 1 of the safety relay to 0V DC. Both contactors de-energize. Verify proper machine-status indication and safety-relay status indication. Repeat for channel 2.		
	While the system is running, short channels 1 and 2 of the safety relay. Both contactors de-energize. Verify proper machine-status indication and safety-relay status indication.		

**GSR Logic Solver Tests**

Test Step	Verification and Validation	Pass/Fail	Changes/Modification
	While the system is running, remove the single wire safety connection between two adjoining safety relays in the system. All contactors de-energize. Verify proper machine-status indication and safety-relay status indication. Repeat for all safety connections. This test is not applicable for single relay circuits.		
	While the system is running, turn the logic rotary switch on the safety relay. All contactors remain energized. Verify proper machine-status indication and safety-relay status indication. Repeat for all safety relays in the system.		

**Safety Contactor Output Tests**

Test Step	Verification and Validation	Pass/Fail	Changes/Modification
	While the system is running, remove the contactor feedback from the safety relay. All contactors remain energized. Initiate a Stop command followed by a Reset command. The relay does not restart or reset. Verify proper machine-status indication and safety-relay status indication.		

## Additional Resources

These publications contain additional information concerning related products from Rockwell Automation.

Resource	Description
440N-Z2NRS1A, 440N-Z2NRS1B, 440N-Z2NRS1C Installation Instructions, publication <a href="#">72673/1</a>	Provides information on installing 440N-Z2NRS1C non-contact switches.
Guardmaster Safety Relay DI Installation Instructions, publication <a href="#">10000175129, Ver 00</a>	Provides information on installing, operating, and maintaining 440R-D22R2 safety relays.
Guardmaster Safety Relay DI Quick Start and Troubleshooting Guide, publication <a href="#">10000175133, Ver 00</a>	Provides guidance on installing, operating, and maintaining 440R-D22R2 (GSR DI) safety relays.
Safety Products Catalog, publication <a href="#">S117-CA001A</a>	Provides overview of products, product specifications, and application examples.

You can view or download publications at <http://www.rockwellautomation.com/literature>. To order paper copies of technical documentation, contact your local Allen-Bradley distributor or Rockwell Automation sales representative.

For More Information on  
Safety Function Capabilities, visit:  
[discover.rockwellautomation.com/safety](http://discover.rockwellautomation.com/safety)

Rockwell Automation, Allen-Bradley, Rockwell Software, Guardmaster, and LISTEN.THINK.SOLVE. are trademarks of Rockwell Automation, Inc. Trademarks not belonging to Rockwell Automation are property of their respective companies.

**[www.rockwellautomation.com](http://www.rockwellautomation.com)**

### Power, Control and Information Solutions Headquarters

Americas: Rockwell Automation, 1201 South Second Street, Milwaukee, WI 53204-2496 USA, Tel: (1) 414.382.2000, Fax: (1) 414.382.4444

Europe/Middle East/Africa: Rockwell Automation NV, Pegasus Park, De Kleetlaan 12a, 1831 Diegem, Belgium, Tel: (32) 2 663 0600, Fax: (32) 2 663 0640

Asia Pacific: Rockwell Automation, Level 14, Core F, Cyberport 3, 100 Cyberport Road, Hong Kong, Tel: (852) 2887 4788, Fax: (852) 2508 1846

Publication SAFETY-AT116A-EN-P – November 2013

Copyright © 2013 Rockwell Automation, Inc. All rights reserved. Printed in U.S.A.