

***msi***<sup>®</sup>

**S6053G481RAU8**

**MS-S428**

Server System  
User Guide

# Contents

Regulatory Notices.....	4
Safety Information .....	7
System Specifications .....	9
System Overview .....	11
Front View.....	11
Rear View .....	11
Rear I/O .....	12
Internal View.....	13
System LED Indicator Status.....	14
Drive Bay LEDs .....	14
Rear I/O LEDs .....	15
Block Diagram .....	16
Motherboard Layout.....	17
Motherboard Components Table.....	18
Motherboard Components.....	19
JCHASSIS1: Chassis Intrusion Header.....	19
BAT1: CMOS Battery .....	20
Motherboard Jumpers .....	21
Motherboard LEDs .....	22
Getting Started .....	23
Necessary Tools.....	23
Safety Precautions .....	23
System Setup.....	24
Drive Bay .....	24
Installing 2.5" Drive .....	24
System Cover.....	25
Removing System Covers.....	25

## Revision

V1.0, 2026/01

System Fan Module.....	26
Installing 8080 Hot-swap System Fan (Front) .....	26
Installing 8080 Hot-swap System Fan (Middle) .....	27
System Fan Cage .....	28
Installing 8080 Middle Fan Cage .....	28
Removing 8080 Middle Fan Cage.....	29
Air Duct.....	30
Installing the Air Duct.....	30
Removing the Air Duct.....	31
CPU & Heatsink .....	32
Installing CPU .....	33
Installing Heatsink.....	36
Memory Slots.....	38
CPU0_DIMM_A1~L1, CPU1_DIMM_A1~L1: DDR5 DIMM Slots .....	38
Recommended Memory Population .....	39
Installing Memory Modules.....	40
M.2 SSD .....	41
Installing M.2 SSD .....	41
PCIe Add-in Card .....	42
Installing GPU Card .....	42
Installing NIC Card.....	43
Power Supply Unit .....	44
Installing Power Supply Unit (PSU) .....	44
Chassis Handle .....	45
Removing the Chassis Handle .....	45
Installing the Chassis Handle.....	46
System Cable Routing .....	47
Power Cables .....	47
PCIe Cables .....	48
Slide Rail.....	49
Prerequisites.....	49
Installing and Removing the Slide Rail.....	50

# Regulatory Notices

## WEEE Statement

**European Union:** This symbol on the product indicates that this product cannot be discarded as municipal waste. Instead, it is your responsibility to dispose of your waste electrical and electronic equipment by handing it over to a designated collection point for recycling. For more information about where you can drop off your waste equipment for recycling, please contact your local city office, your household waste disposal service or the shop where you purchased the product.



## CE Conformity

This product has been tested and found to comply with the harmonized standards for Information Technology Equipment published under Directives of the Official Journal of the European Union.



## FCC-A Radio Frequency Interference Statement

This equipment has been tested and found to comply with the limits for a Class A digital device, pursuant to Part 15 of the FCC Rules. These limits are designed to provide reasonable protection against harmful interference when the equipment is operated in a commercial environment. This equipment generates, uses and can radiate radio frequency energy and, if not installed and used in accordance with the instruction manual, may cause harmful interference to radio communications. Operation of this equipment in a residential area is likely to cause harmful interference, in which case the user will be required to correct the interference at his own expense.



### Notice 1

The changes or modifications not expressly approved by the party responsible for compliance could void the user's authority to operate the equipment.

### Notice 2

Shielded interface cables and AC power cord, if any, must be used in order to comply with the emission limits.

This device complies with Part 15 of the FCC Rules. Operation is subject to the following two conditions:

- This device may not cause harmful interference, and
- This device must accept any interference received, including interference that may cause undesired operation.

## Chemical Substances Information

In compliance with chemical substances regulations, such as the EU REACH Regulation (Regulation EC No. 1907/2006 of the European Parliament and the Council), MSI provides the information of chemical substances in products at:

<https://csr.msi.com/global/index>

## Battery Information

Please take special precautions if this product comes with a battery.

- Danger of explosion if battery is incorrectly replaced. Replace only with the same or equivalent type recommended by the manufacturer.
- Avoid disposal of a battery into fire or a hot oven, or mechanically crushing or cutting of a battery, which can result in an explosion.
- Avoid leaving a battery in an extremely high temperature or extremely low air pressure environment that can result in an explosion or the leakage of flammable liquid or gas.
- Do not ingest battery. If the coin/button cell battery is swallowed, it can cause severe internal burns and can lead to death. Keep new and used batteries away from children.

### European Union:



Batteries, battery packs, and accumulators should not be disposed of as unsorted household waste. Please use the public collection system to return, recycle, or treat them in compliance with the local regulations.

### BSMI:



廢電池請回收

For better environmental protection, waste batteries should be collected separately for recycling or special disposal.

### California, USA:



The button cell battery may contain perchlorate material and requires special handling when recycled or disposed of in California. For further information please visit:

<http://www.dtsc.ca.gov/hazardouswaste/perchlorate/>

## Environmental Policy

- The product has been designed to enable proper reuse of parts and recycling and should not be thrown away at its end of life.
- Users should contact the local authorized point of collection for recycling and disposing of their end-of-life products.
- Visit the MSI website and locate a nearby distributor for further recycling information.
- Users may also reach us at [gpcontdev@msi.com](mailto:gpcontdev@msi.com) for information regarding proper disposal, take-back, recycling, and disassembly of MSI products.
- Please visit <https://us.msi.com/page/recycling> for information regarding the recycling of your product in the US.



## Copyright and Trademarks Notice

***msi*** **MSI** **微星** **微星科技**

MICRO-STAR INTERNATIONAL



Copyright © Micro-Star Int'l Co., Ltd. All rights reserved. The MSI logo used is a registered trademark of Micro-Star Int'l Co., Ltd. All other marks and names mentioned may be trademarks of their respective owners. No warranty as to accuracy or completeness is expressed or implied. MSI reserves the right to make changes to this document without prior notice.

## Technical Support

If a problem arises with your product and no solution can be obtained from the user's manual, please contact your place of purchase or local distributor. Alternatively, please visit <https://eps.msi.com/support> for further guidance.

# Safety Information



***Please read and follow these safety instructions carefully before installing, operating or performing maintenance on the server.***

## General Safety Instructions

- Always read the safety instructions carefully.
- Keep this User's Manual for future reference.
- Keep this equipment away from humidity.
- Lay the equipment on a stable, flat surface before setting it up.
- Do not cover the air openings to prevent overheating.
- Avoid spilling liquids into the equipment to prevent damage or electrical shock.
- Do not leave the equipment in an unconditioned environment. Storage temperatures above 60°C (140°F) may cause damage.

## Electrical Safety

### Power Setup and Protection

- Ensure the power source matches the equipment voltage before connection.
- Plug the power cord into a grounded (earthed) electrical outlet that is easily accessible at all times. Do not disable the power cord grounding plug, as it is an important safety feature.
- Do not use a power adapter other than the one provided.
- Place the power cord to avoid being stepped on or crushed.
- Protect the server from power fluctuations and outages using a regulated uninterruptible power supply (UPS).

### Handling Power Connections

- Unplug the power cord before inserting add-on cards or modules.
- Disconnect all power supplies before maintenance to avoid electrical shock. If the unit has more than one power supply, disconnect all of them.
- Unplug the power cord to fully disconnect the system. The front panel Power On/Standby button does not completely shut off system power. Portions of the power supply and some internal circuitry remain active until AC/DC power is removed.

## Assembly and Installation

This equipment must be installed in restricted access areas by qualified personnel to comply with safety standards set by the NEC and IEC 62368-1, Third Edition, for Information Technology Equipment.

### Lifting and Placement

- **WARNING:** This server is heavy.
- Follow occupational health and safety guidelines for manual material handling.
- A minimum of two persons is required to lift or install the server. For installations above chest height, a third person may be needed for alignment.
- Exercise caution when installing or removing the server from the rack, as it may become unstable when not fastened to the rails.

### Hot Surfaces

- Allow components like drives and power supplies to cool before touching.

### Energy Pack Handling after Removal

To reduce the risk of fire or burns:

- Do not disassemble, crush, or puncture the energy pack.
- Avoid shorting external contacts.
- Do not dispose of the energy pack in fire or water.

### Other Components

- Keep away from hazardous moving parts, such as fan blades, to prevent injury.
- Do not drop or jolt the system, as this may damage internal components or compromise safety.

## General Precautions During Operation

- Avoid operating the server with the access panel open or removed for extended periods, as this disrupts airflow and may cause overheating.
- Do not insert incorrect connectors into ports to avoid damage to components or the risk of electrical hazards.
- This equipment is not suitable for use in locations where children are likely to be present.

## When to Contact Service Personnel

Seek immediate assistance from qualified personnel if any of the following occurs:

- The power cord or plug is damaged.
- Liquid has entered the equipment.
- The equipment has been exposed to moisture.
- The equipment does not function as described in the User Guide.
- The equipment has been dropped or physically damaged.
- The equipment shows visible signs of breakage.

# System Specifications

<b>SKU Name</b>	<b>S6053G481RAU8</b>
<b>Form factor</b>	4U
<b>Dimensions</b>	438mm(17.2")W x 175mm(6.88")H x 800mm(31.4")D
<b>Processor</b>	Dual AMD EPYC™ 9005 series processors, TDP up to 500W
<b>Socket</b>	2 x LGA 6096 (Socket SP5)
<b>Chipset</b>	N/A
<b>Memory</b>	<ul style="list-style-type: none"> <li>• 24 x DDR5 DIMM slots, 12 channels per CPU (1DPC), RDIMM/ RDIMM-3DS</li> <li>- Max Frequency: 6400 MT/s</li> <li>- Max Capacity per DIMM: 256 GB</li> </ul>
<b>Drive Bays</b>	8 x Front hot-swap 2.5" U.2 PCIe 5.0 x4 NVMe drive bays
<b>Internal Storage</b>	2 x 2280/22110 PCIe 3.0 x2 NVMe M.2 slots (M-key, from CPU0)
<b>Expansion Slots</b>	<ul style="list-style-type: none"> <li>• 8 x PCIe 5.0 x16 FHFL double-wide slots (through ConnectX-8 switch board)</li> <li>• 1 x PCIe 5.0 x16 FHFL single-wide slot (from CPU0)</li> </ul>
<b>Networking</b>	8 x QSFP112 ports with NVIDIA ConnectX-8 chipsets
<b>Front I/O</b>	8 x Hot-swap 2.5" U.2 drive bays
<b>Rear I/O</b>	<ul style="list-style-type: none"> <li>• 1 x 1GbE RJ45 Ethernet port (1000BASE-T; dedicated management)</li> <li>• 8 x QSFP112 ports</li> <li>• 1 x USB 3.2 Gen 1 Type-A port (5 Gbps)</li> <li>• 1 x Mini-DisplayPort</li> <li>• 1 x Power LED (Green) button</li> <li>• 1 x UID LED (Blue) button</li> </ul>
<b>Security</b>	<ul style="list-style-type: none"> <li>• Chassis Intrusion</li> <li>• On-board TPM 2.0</li> <li>• Hardware Root of Trust- Microchip CEC1736 supported (optional)</li> </ul>
<b>Server Management</b>	<ul style="list-style-type: none"> <li>• 1 x 1GbE RJ45 Ethernet port (1000BASE-T; dedicated management)</li> <li>• ASPEED AST2600 with AMI MegaRAC based firmware               <ul style="list-style-type: none"> <li>- Supports IPMI 2.0 and DMTF Redfish® API</li> </ul> </li> <li>• Dual BIOS and dual BMC supported*</li> <li>• eMMC for local BMC storage media</li> </ul> <p>*Dual BIOS is exclusively implemented to support the Embedded Root of Trust (ERoT).</p>
<b>Cooling</b>	<ul style="list-style-type: none"> <li>• 2 x EVAC air cooling modules for max 500W CPU</li> <li>• 10 x 8080 hot-swap system fans</li> </ul>

Continued on next column

<b>SKU Name</b>	<b>S6053G481RAU8</b>
<b>Environment</b>	<ul style="list-style-type: none"> <li>• Operating Temperature: 10°C ~ 35°C (50°F ~ 95°F)</li> <li>• Operating Humidity: 8% to 85% (non-condensing)</li> <li>• Non-operating Temperature: -30°C ~ 60°C (-40°F to 140°F)</li> <li>• Non-operating Relative Humidity: 8% to 90% (non-condensing)</li> </ul>
<b>Power Supply</b>	<ul style="list-style-type: none"> <li>• (3+1) Redundant 3200W CRPS, 80PLUS Titanium</li> <li>- Dimension (WxHxL): 73.5 x 40 x 185 mm</li> </ul>
<b>Certification</b>	CE, FCC (Class A)

# System Overview



## Front View

8 x 2.5" U.2 Drive Bays  
(PCIe 5.0 x4)

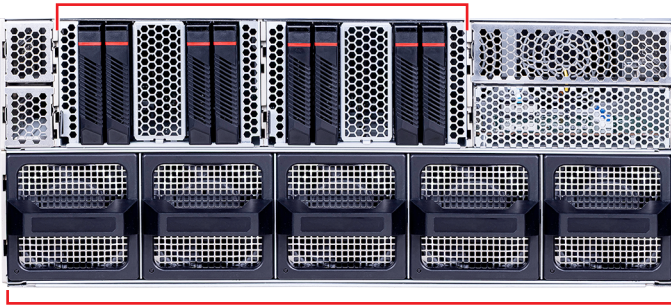

5 x 8080 Hot-Swap System Fans

## Rear View

#1: FHFL single-wide slot (for NIC)  
#2-9: FHFL double-wide slots

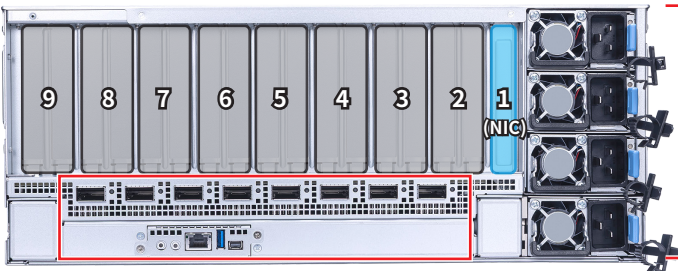

Power  
Supply  
Units

refer to "[Rear I/O](#)" for details

# Rear I/O

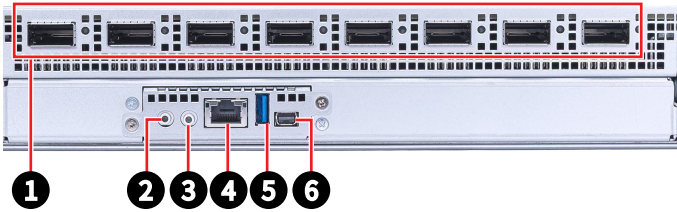

<b>1</b>	<b>QSFP112 Port</b> Provides <b>400Gbps</b> connectivity powered by <b>NVIDIA ConnectX-8</b> chipset.
<b>2</b>	<b>System Power LED Button</b> Press the power button to turn the system on and off.
<b>3</b>	<b>UID LED Button</b> The UID (Unit Identification) LED button help users identify and locate a system, especially in high-density rack environments.
<b>4</b>	<b>1000BASE-T RJ45 Ethernet Port (dedicated management)</b> Provides a <b>1 Gbps RJ45 dedicated out-of-band management interface</b> connected to the BMC. Use this port for system management, monitoring, and remote access.
<b>5</b>	<b>USB 3.2 Gen 1 Type-A Port</b> This connector is provided for USB peripheral devices. (Speed up to <b>5 Gbps</b> )
<b>6</b>	<b>Mini-DisplayPort</b> This port is a compact version of DisplayPort, used for connecting displays. With the appropriate <b>active adapter</b> , it supports connections to VGA, DVI, or HDMI displays.  <b>Important</b> <i>This Mini-DisplayPort does <b>not support DP++ (Dual-Mode DisplayPort)</b>, so passive adapters are not compatible.</i>

# Internal View

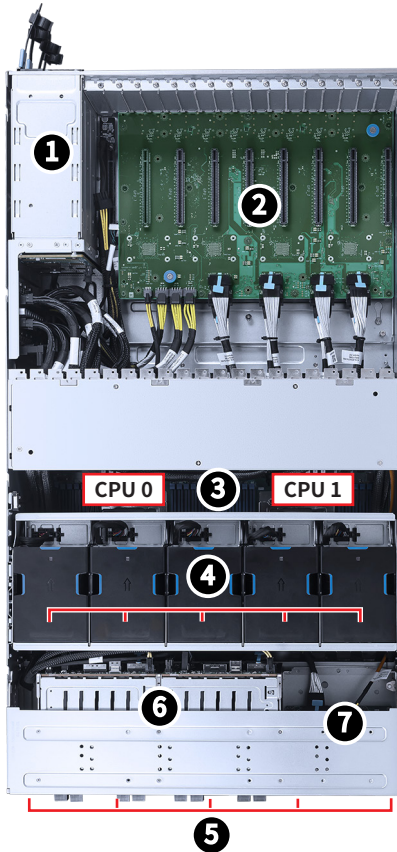

<b>1</b>	(3+1) 185mm 3200W CRPS PSU
<b>2</b>	ConnectX-8 Switch Board
<b>3</b>	Motherboard
<b>4</b>	5 x 8080 Hot-Swap System Fans (upper, for GPU)
<b>5</b>	5 x 8080 Hot-Swap System Fans (bottom, for CPU)
<b>6</b>	8 x Hot-Swap 2.5" U.2 Drive Bays (PCIe 5.0 x4 NVMe)
<b>7</b>	M.2 Riser Board

# System LED Indicator Status

## Drive Bay LEDs

(Left) Drive Activity LED

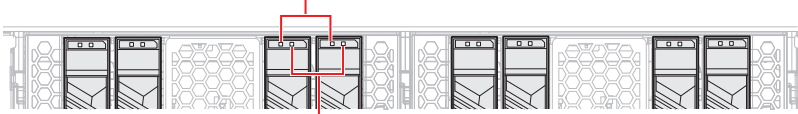

(Right) Drive Status LED

LED	LED State	Description
Drive Activity LED	● Green	Drive present, no activity
	● 4Hz Blinking (4 blinks per second)	Drive present, activity occurring
	○ Off	Drive not present
Drive Status LED	● Orange	Drive failure, swap the drive immediately
	● 1Hz Blinking (1 blink per second)	RAID rebuilding
	● 4Hz Blinking (4 blinks per second)	Locate the drive
	○ Off	Drive not present

# Rear I/O LEDs

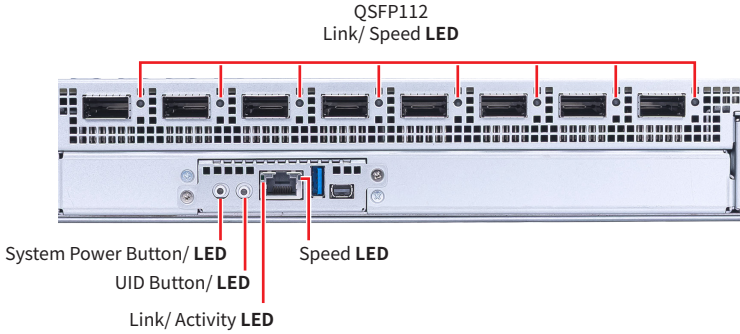

LED	LED State	Description
System Power LED	<input checked="" type="radio"/> Green	System power is on
		System power is on ACPI S0 state
	<input type="radio"/> Off	System power is off
		System power is on ACPI S5 state
UID LED	<input checked="" type="radio"/> Blue	Identify active via command or button
	<input type="radio"/> Off	No identification
Link/ Activity LED (for 1000Base-T Ethernet)	<input checked="" type="radio"/> Green	Ethernet link is established.
	<input checked="" type="radio"/> Blinking	Ethernet activity is occurring.
	<input type="radio"/> Off	Ethernet link is not established.
Speed LED (for 1000Base-T Ethernet)	<input checked="" type="radio"/> Green	1 Gbps
	<input checked="" type="radio"/> Orange	100 Mbps
	<input type="radio"/> Off	Ethernet link is not established.
Link/ Speed LED (for QSFP112)	<input checked="" type="radio"/> Green	Ethernet link is established at full port speed.
	<input checked="" type="radio"/> Yellow	Ethernet link is established at less than full port speed.
	<input type="radio"/> Off	Ethernet link is not established.

# Block Diagram

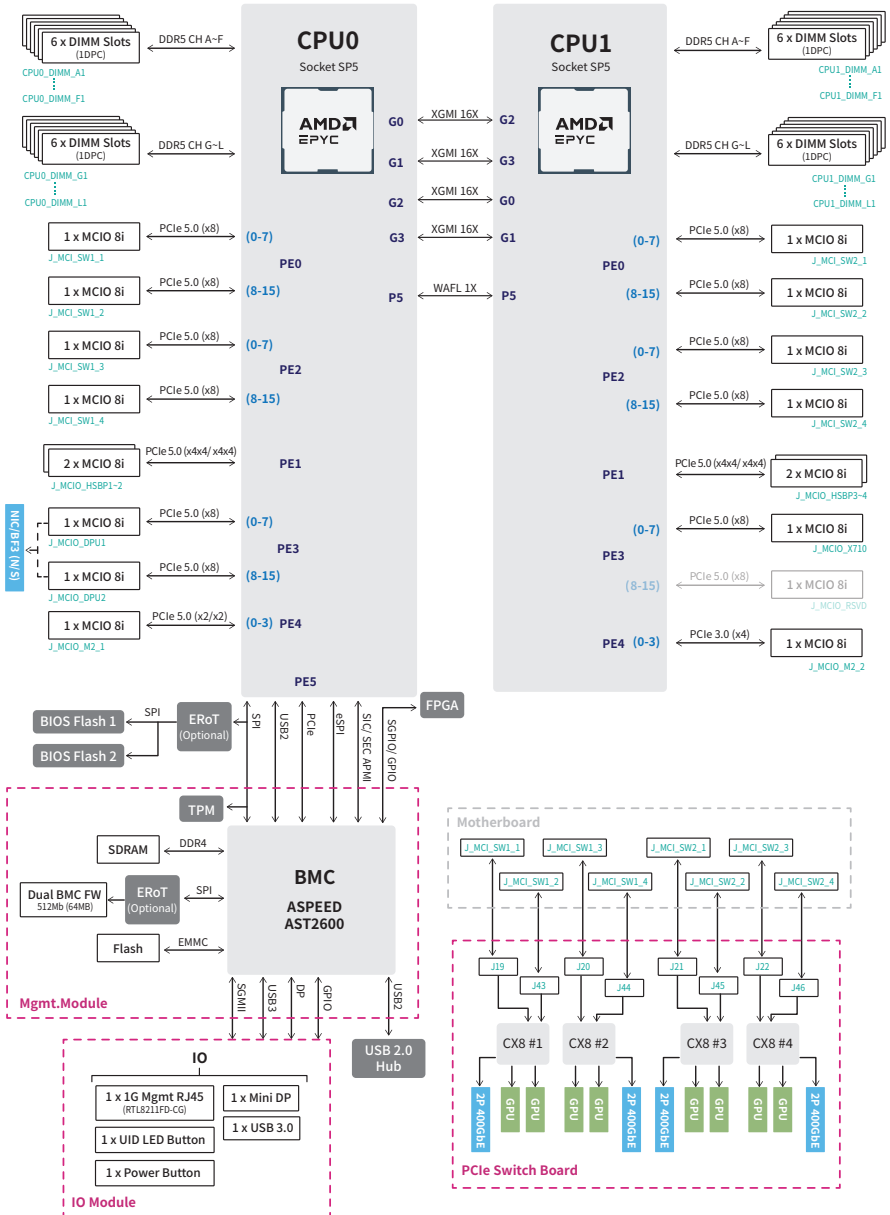

# Motherboard Layout

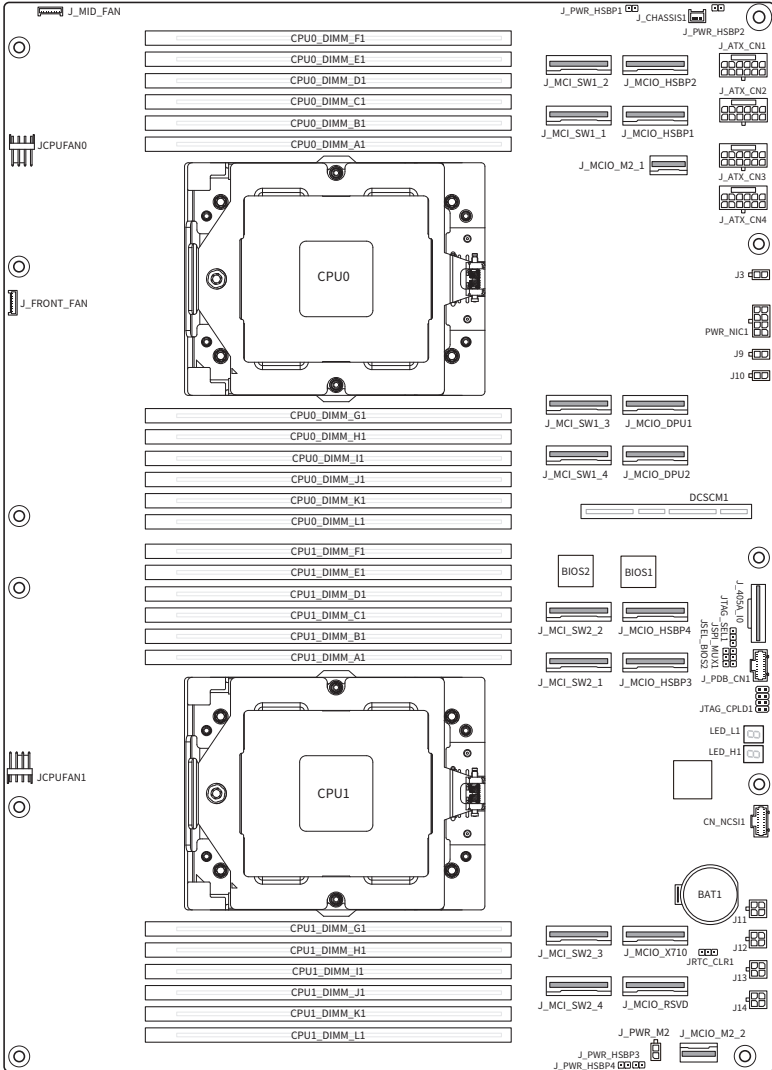

# Motherboard Components Table

Name	Description
<b>Connectors, Headers and Other Components</b>	
CPU0, CPU1	LGA 6096 (Socket SP5)
CPU0_DIMM_A1~CPU0_DIMM_L1	DDR5 DIMM slots (from CPU0)
CPU1_DIMM_A1~CPU1_DIMM_L1	DDR5 DIMM slots (from CPU1)
J3	2-pin P12V_AUX power connector (PSU 12V standby power)
J9	2-pin P12V_AUX power connector (for rear I/O board)
J10	2-pin P12V_AUX power connector (for Intel X710 NIC)
J_PWR_M2	2-pin P3V3 power connector
J11~J14	4-pin power connectors (for CEM riser cards)
PWR_NIC1	8-pin P12V_AUX power connector (for CX8 standby power)
J_ATX_CN1~4	12-pin ATX 3.0 power connectors (input from PIB)
J_MCI_SW1_1~4	MCIO 8i connectors (PCIe 5.0 x8, from CPU0, for PCIe GPU board)
J_MCI_SW2_1~4	MCIO 8i connectors (PCIe 5.0 x8, from CPU1, for PCIe GPU board)
J_MCIO_HSBP1~2	MCIO 8i connectors (PCIe 5.0 x4/x4, from CPU0, for HSBP)
J_MCIO_HSBP3~4	MCIO 8i connectors (PCIe 5.0 x4/x4, from CPU1, for HSBP)
J_MCIO_DPU1~2	MCIO 8i connectors (PCIe 5.0 x8, from CPU0, for DPU riser, with CXL)
J_MCIO_X710	MCIO 8i connector (PCIe 5.0 x8, from CPU1, for Intel X710 NDC)
J_MCIO_RSVD	MCIO 8i connector (PCIe 5.0 x8, from CPU1)
J_MCIO_M2_1	MCIO 4i connector (PCIe 3.0 x4, from CPU0, for M.2 riser board)
J_MCIO_M2_2	MCIO 4i connector (PCIe 3.0 x4, from CPU1)
JCPUFAN1~2	4-pin fan connectors (debug only)
J_FRONT_FAN	Front fan board signal header
J_MID_FAN	Middle fan board signal header
DCSCM1	DC-SCM 2.0 slot (for MGX defined BMC management module)
CN_NCSI	NCSI connector
J_PDB_CN1	PDB board sideband signal connector
J_405A_IO1	BMC IO board connector
JCHASSIS1	Chassis intrusion header
BAT1	CMOS battery
<b>Jumpers</b>	
JRTC_CLR1	CMOS clear jumper
<b>LEDs</b>	
LED_H1, LED_L1	Port 80 debug LEDs

# Motherboard Components

## JCHASSIS1: Chassis Intrusion Header

This header connects to the **chassis intrusion switch cable**, which monitors and detects any unauthorized opening in the server's chassis. When the chassis is opened, this header sends a signal to notify the **Baseboard Management Controller (BMC)** to record the intrusion event or trigger an alert for administrators.

JCHASSIS1	1		1	FM_INTRUSION_CBL_PRES_N
			2	GND
			3	FM_INTRUDER_HDR_BMC_N

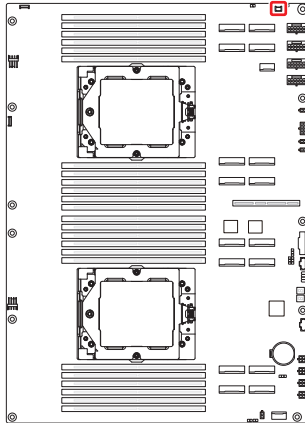

## BAT1: CMOS Battery

If the CMOS battery is out of charge, the time in the BIOS will be reset and the data of system configuration will be lost. In this case, you need to replace the CMOS battery.

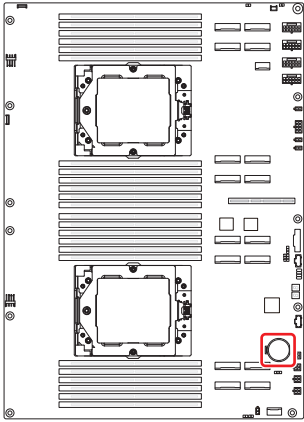

### Replacing CMOS battery

1. Push the retainer clip to free the battery.
2. Remove the battery from the socket.
3. Install the new CR2032 coin-cell battery with the + sign facing up. Ensure that the retainer holds the battery securely.

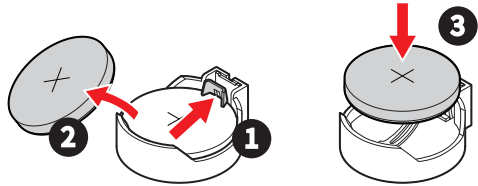

### WARNING

#### KEEP OUT OF REACH OF CHILDREN

- Swallowing can cause chemical burns, perforation of soft tissue, and even death.
- Severe burns can occur within 2 hours of ingestion.
- If you think batteries might have been swallowed or placed inside any part of the body, seek immediate medical attention.

# Motherboard Jumpers

 **Important**

Avoid adjusting jumpers when the system is on; it will damage the motherboard.

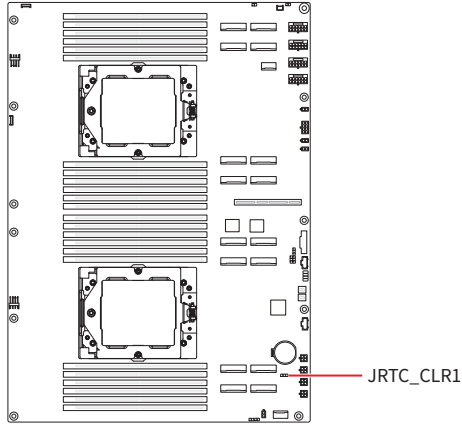

Jumper Name	Default Setting	Description
JRTC_CLR1		<b>CMOS Clear Jumper</b>
		1-2: Normal (default) 2-3: Clear CPU0 CMOS

# Motherboard LEDs

## LED\_H1, LED\_L1: Port 80 Debug LEDs

The Port 80 Debug LEDs display progress and error codes during and after POST (Power-On Self Test).

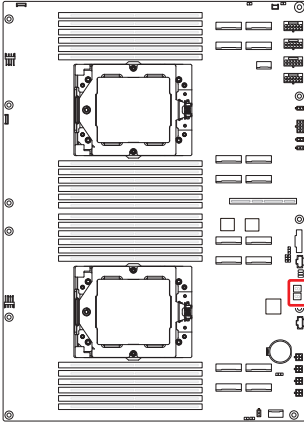

Hexadecimal Character Table

Hexadecimal	0	1	2	3	4	5	6	7
LED display	0	1	2	3	4	5	6	7
Hexadecimal	8	9	A	B	C	D	E	F
LED display	8	9	A	b	C	d	E	F

# Getting Started

## **Important**

- All information is subject to change without prior notice.
- The system photos are provided for demonstration purposes only. The appearance and internal view of your system may vary.

## Necessary Tools



Screwdriver



Pliers



Tweezers



Anti-Static Gloves

## Safety Precautions

The following precautions should be observed while handling the system:

- Place the system on a flat and stable surface.
- Do not place the system in environments subject to mist, smoke, vibration, excessive dust, salty or greasy air, or other corrosive gases and fumes.
- Do not drop or jolt the system.
- Do not use a power adapter other than the one enclosed with the system.
- Disconnect the power cord before performing any installation procedures on the system.
- Do not perform any maintenance with wet hands.
- Prevent foreign substances, such as water, other liquids or chemicals, from entering the system while performing installation procedures.
- Use a grounded wrist strap before handling system components such as CPU, Memory, HDD, expansion cards, etc.
- Place system components on a grounded anti-static pad or on the bed that came with the components whenever the components are separated from the system.

# System Setup

## Important

Before removing or installing any components, make sure the system is not turned on or connected to the power.

## Drive Bay

### Installing 2.5" Drive

1. Press the release button to open the latch and eject the drive carrier.
2. Engage two embossed pins on one side of the carrier with the side dimples on the drive.
3. Carefully push down on the other side of the drive until the remaining two embossed pins lock into place.
4. With the lever open, insert the drive assembly vertically into the drive bay until the locking lever engages.
5. Push the lever in to lock it in place.

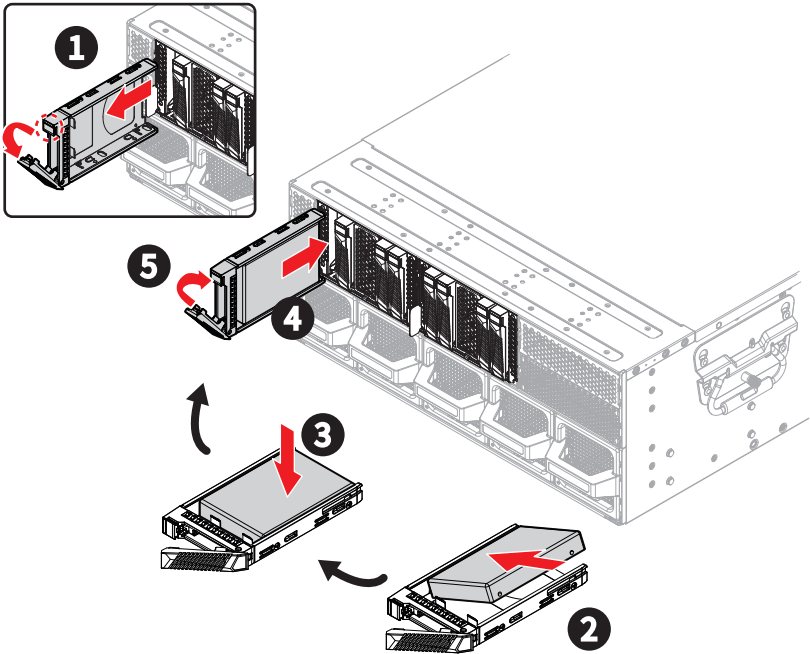

# System Cover

## Removing System Covers

1. Remove the **screws** securing both sides of the chassis.
2. Press down on the **latches** and slide the cover to the back, then lift it off the system.

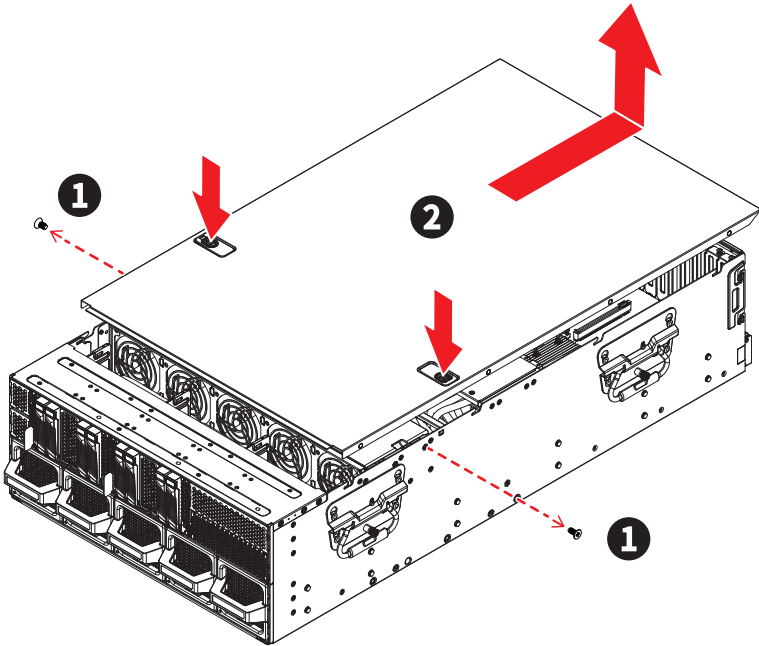

# System Fan Module

## Installing 8080 Hot-swap System Fan (Front)

1. Press the **release tab** behind the handle, then slide the fan into the slot.
2. Release the tab to allow the fan lock securely into place.

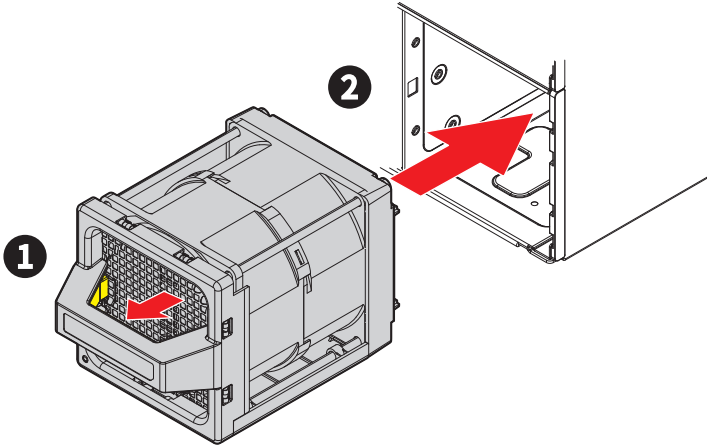

## Installing 8080 Hot-swap System Fan (Middle)

1. Align the fan connectors with the slot.
2. **Press and hold the fan release tabs**, then slide the fan assembly fully into the slot.
3. Release the tabs to allow the fan to lock securely into place.

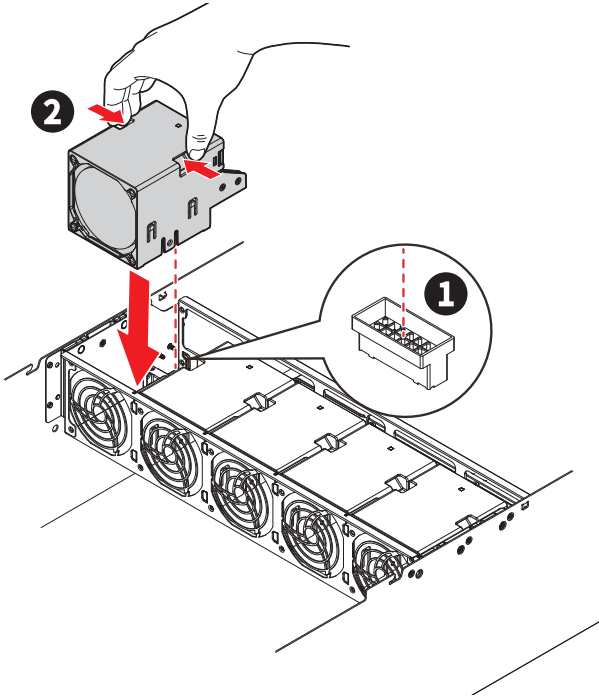

# System Fan Cage

## Installing 8080 Middle Fan Cage



Ensure all cables are clear of the fan cage installation area before proceeding.

1. **Align** the fan cage with the chassis by matching the studs to their designated slots.
2. **Lower the fan cage** carefully until it is firmly seated and fully engaged.
- As the middle fan cage is lowered, it will push the air duct forward and press it down into position.
3. **Tighten the screws** on both sides of the chassis to securely lock the fan cage into place.

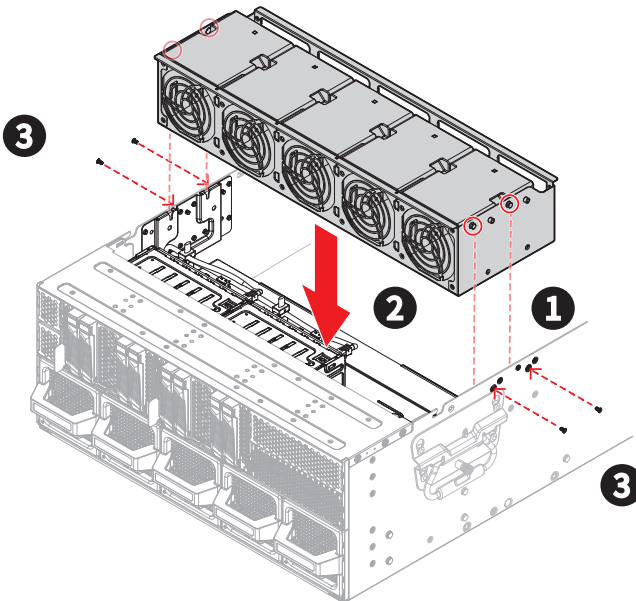

## Removing 8080 Middle Fan Cage



**Important**

*Ensure all cables are clear of the fan cage installation area before proceeding.*

1. **Loosen the screws** on both sides of the chassis securing the fan cage.
2. **Lift the fan cage** carefully upward until it disengages from the studs.
3. **Remove the fan cage** from the chassis, ensuring no cables are caught during removal.

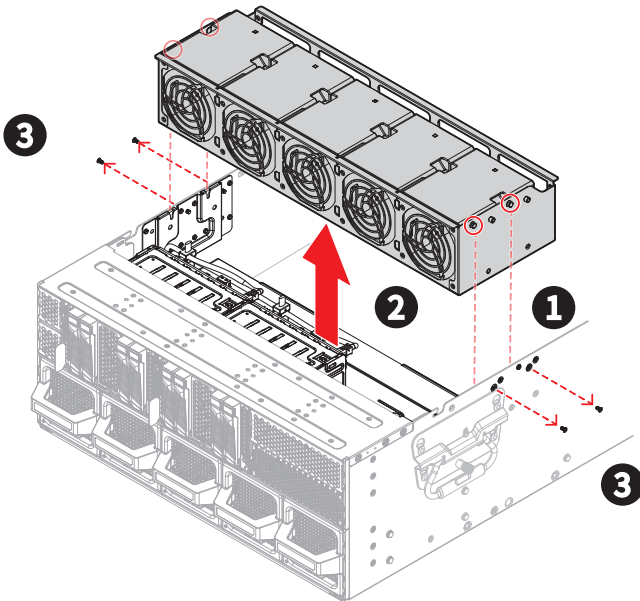

# Air Duct

## Installing the Air Duct

1. Lower the air duct into place until it is securely seated.
2. As the middle fan cage is installed, it will push the air duct forward and press it down into position.  
(see "[Installing the 8080 Middle Fan Cage](#)")

 **Important**

Cables run along both sides of the air duct and near the front metal parts. **Take care not to press, squeeze, or damage these cables during installation.**

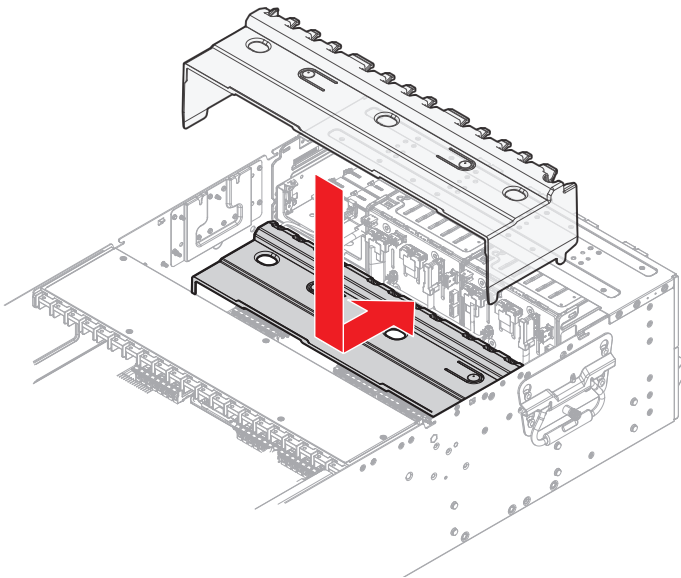

## Removing the Air Duct

1. Remove the middle fan cage to release pressure on the air duct.  
(see [“Removing the 8080 Middle Fan Cage”](#))
2. Slide the air duct backward slightly to clear the front hooks, then lift the air duct upward to remove it from the system.

 **Important**

*Be careful not to pull or damage the cables routed along both sides and the front of the air duct.*

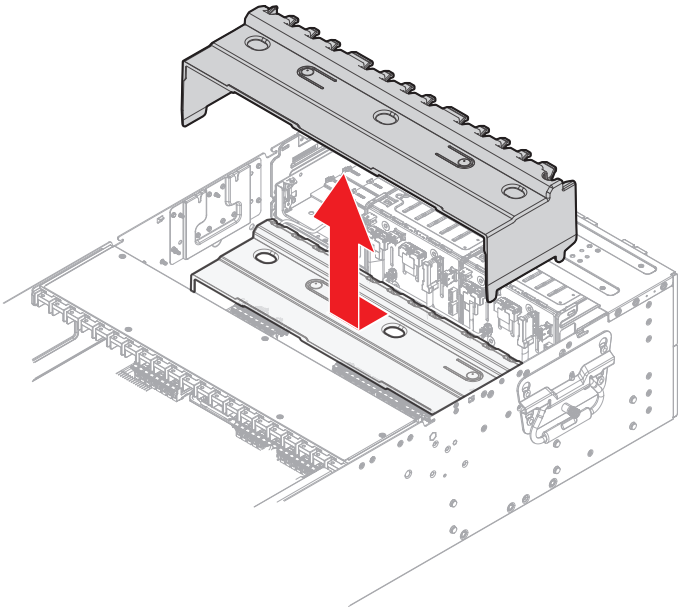

# CPU & Heatsink

Use appropriate ground straps, gloves and ESD mats to protect yourself from electrostatic discharge (ESD) while installing the processor.

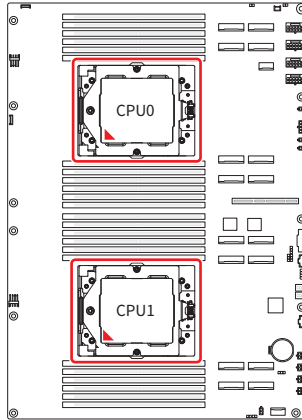

## Important

- While **replacing the CPU**, always turn off the power supply or unplug the power supply's power cord from the grounded outlet first to ensure the safety of CPU.
- **Overheating** will seriously damage the CPU and system. Always make sure the cooling fan can work properly to protect the CPU from overheating. Make sure to apply an even layer of thermal paste (or thermal tape) between the CPU and the heatsink to enhance heat dissipation.
- Please refer to the documentation in the CPU cooler package for more details about the CPU cooler installation.
- Whenever CPU is not installed, always protect your CPU socket pins with the plastic cap covered.
- Do not touch the CPU socket content to avoid damage.
- Read the CPU status in BIOS.

## Installing CPU

Before installing the CPU and heatsink, remove the 8080 fan cage and air duct. (see [“Removing the 8080 Middle Fan Cage”](#) and [“Removing the Air Duct”](#))

### **Important**

*Images are for illustration purposes only; actual parts may vary.*

1. Remove the screw on the top of the retention frame.

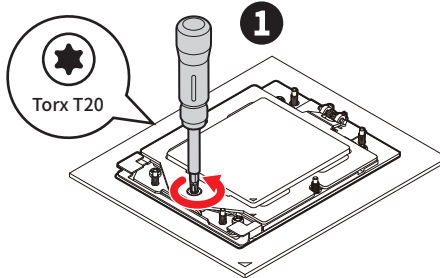

2. After removing the top screw, the **spring-loaded retention frame** will rise up. Hold it gently until it is fully open.
  3. Lift the **rail frame** by gripping the lift tabs near the front edge of the rail frame.
- *As both frames are spring-loaded, keep a tight grip on them while lifting to avoid an abrupt swinging motion.*

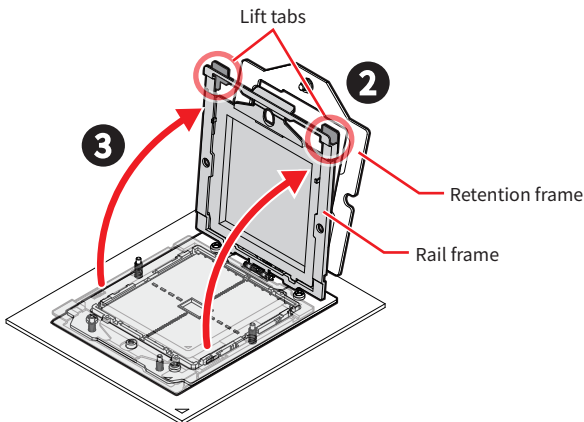

4. Pull the **external cap** upward through the rail guides on the rail frame to remove it.
  5. Grip the handle of the **carrier frame** and slide it downward with the flanges and the rail guides aligned.
- CPUs are shipped from the factory with pre-assembled carrier frames.
  - Make sure the flanges of the carrier frame are firmly loaded on the rails before closing the rail frame.

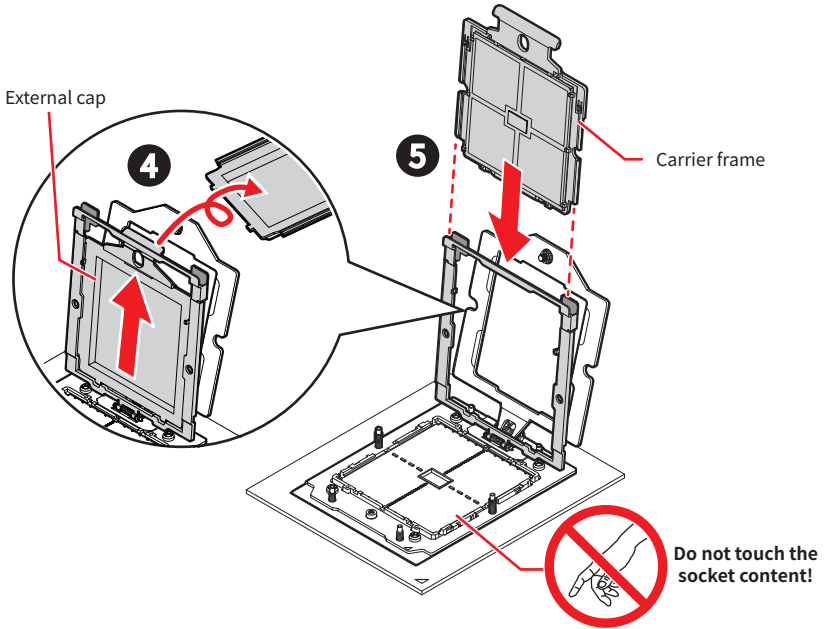

6. Grip the **lift tabs at the front edge of the rail frame** with the carrier frame loaded, then gently lower it to engage the carrier's latching mechanism to the socket housing.

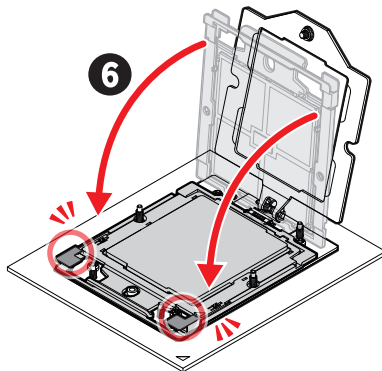

7. Push the **retention frame** downward and use a torque screwdriver to tighten the screw in the middle.

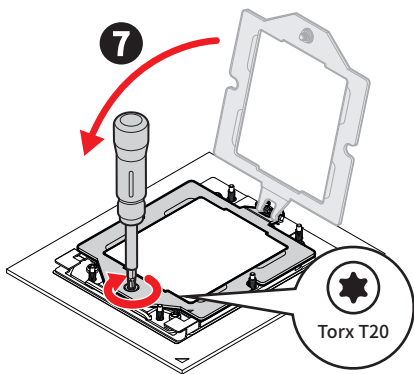

**Torque Screwdriver Settings**  
**Screw Head:** Torx T20  
**Torque:** 12.5-15 kgf·cm\*  
\*12.5-15 kgf·cm  
= 1.23-1.47 N·m  
= 10.8-13 lbf·in

# Installing Heatsink

## Access Requirements & Tooling

To ensure safe and smooth installation of screws #7 and #8, the drive cage must be temporarily moved to create clearance.

- **Required Tool:** You must use a screwdriver with a shank length exceeding **35mm**.

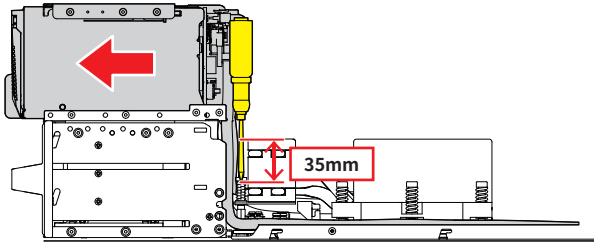

- **Access Note:**  
To unlock the cage, gently **push the release switch inwards** and slide the cage outwards. This action is **mandatory** for accessing screws #7 and #8.

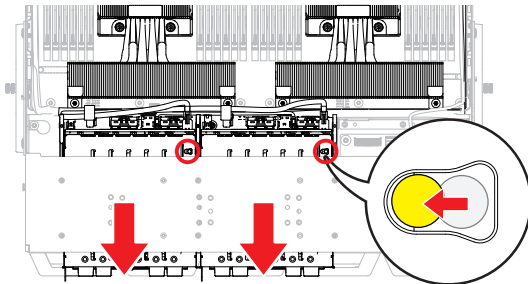

## Installation Procedure

- 1. Apply Thermal Paste:** For peak thermal performance, apply a proper amount of thermal paste to the bottom center of the heatsink. (Skip this step if there is pre-applied thermal paste.)
  - *Handling Note:* To avoid damaging the fins of the heatsink, always grip the heatsink **along the axis of the fins**. Holding a heatsink along the side might damage its fins or solder.
- 2. Position Heatsink:** Lower the heatsink until it rests firmly in place after aligning the eight screw holes on its bottom with the motherboard's studs.
- 3. Initial Securing (Screws #1-#6):**  
To avoid distributing uneven pressure on the CPU, loosely attach screws #1 through #6 in a diagonal sequence. Then, gradually tighten these six screws using a torque screwdriver.
- 4. Secure Final Screws (#7 and #8):**
  - Perform the unlock procedure outlined in the "[Access Note](#)" above.
  - Secure screws #7 and #8.

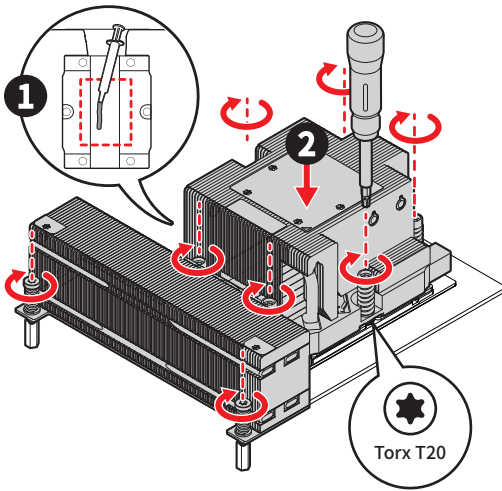

### Torque #1-6: 12.5-15 kgf·cm\*

\*12.5-15 kgf·cm  
= 1.23-1.47 N·m  
= 10.8-13 lbf·in

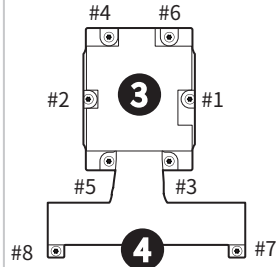

### Torque #7-8: 4.5-5 kgf·cm\*\*

\*\*4.5-5 kgf·cm  
= 0.44-0.49 N·m  
= 3.9-4.4 lbf·in

- 5. Lock the Drive Cage:** If the drive cage was moved, slide the cage back into its original position and ensure the assembly is fully locked.
  - *Confirm if your heatsink is firmly installed before turning on your system.*

After installing the CPU and heatsink, install the air duct and the 8080 fan cage back to the chassis. (see "[Installing the Air Duct](#)" and "[Installing the 8080 Middle Fan Cage](#)")

# Memory Slots

## CPU0\_DIMM\_A1~L1, CPU1\_DIMM\_A1~L1: DDR5 DIMM Slots

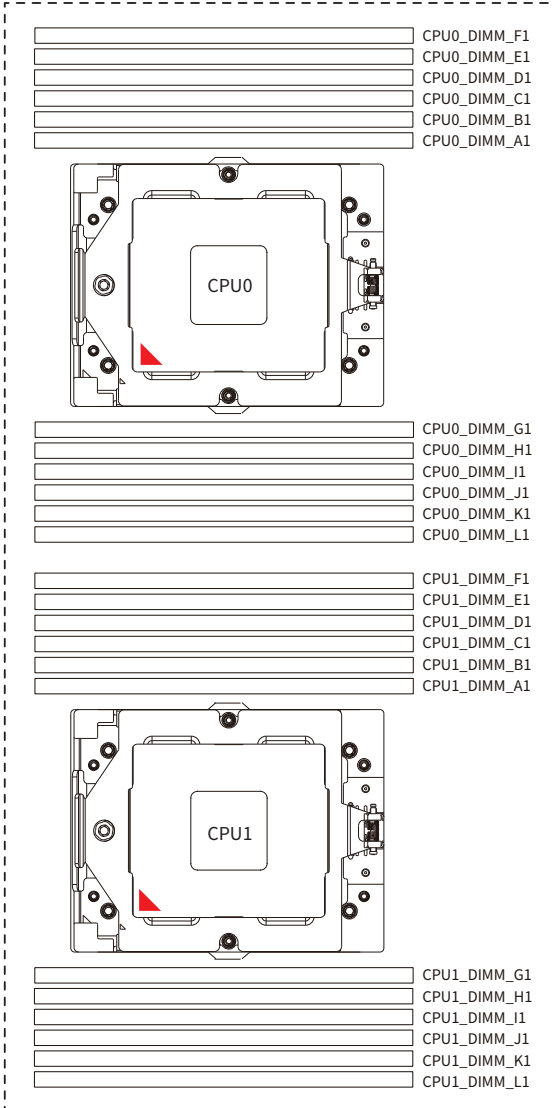

# Recommended Memory Population

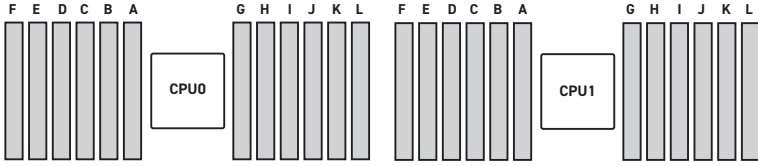

1 CPU															
Channel		F	E	D	C	B	A	C P U	G	H	I	J	K	L	
Qty. of DDR5		V	V	V	V	V	V		V	V	V	V	V	V	V
12			V	V	V	V	V		V	V	V	V	V	V	V
10			V	V	V	V	V		V	V	V	V	V	V	
8			V		V	V	V		V	V	V	V	V	V	
6					V	V	V		V	V	V	V			
4					V		V		V	V					
2							V		V						
1							V	V							

2 CPUs															
Channel		F	E	D	C	B	A	C P U	G	H	I	J	K	L	
24	CPU1	V	V	V	V	V	V		V	V	V	V	V	V	V
	CPU0	V	V	V	V	V	V		V	V	V	V	V	V	V
20	CPU1		V	V	V	V	V		V	V	V	V	V	V	
	CPU0		V	V	V	V	V		V	V	V	V	V	V	
16	CPU1		V		V	V	V		V	V	V	V		V	
	CPU0		V		V	V	V		V	V	V	V		V	
12	CPU1				V	V	V		V	V	V	V			
	CPU0				V	V	V		V	V	V	V			
8	CPU1				V		V		V	V		V			
	CPU0				V		V		V	V		V			
4	CPU1						V		V	V					
	CPU0						V		V	V					
2	CPU1						V		V						
	CPU0						V		V						
1	CPU1								V						
	CPU0						V		V						

"V" indicates DIMMs are populated with DDR5.

**Important**

There should be at least one DDR5 DIMM populated.

## Installing Memory Modules

1. Open the side clips to unlock the DIMM slot.
2. Insert the DIMM vertically into the slot, ensuring that the off-center notch at the bottom aligns with the slot.
3. Push the DIMM firmly into the slot until it clicks and the side clips automatically close.
4. Verify that the side clips have securely locked the DIMM in place.

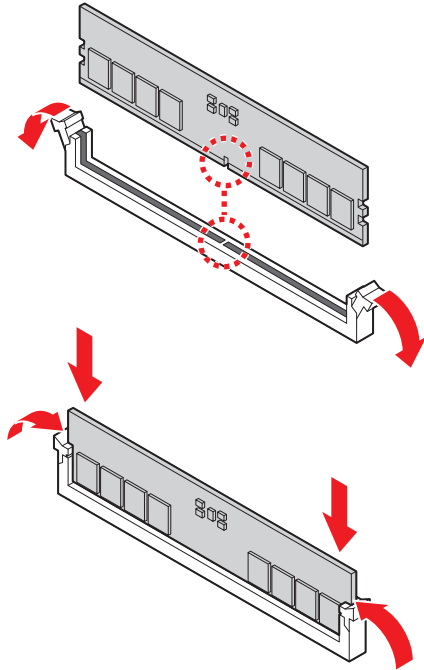

### **Important**

*You can barely see the golden finger if the memory module is properly inserted in the DIMM slot.*

# M.2 SSD

## Installing M.2 SSD

1. Adjust the **M.2 board latch** to fit your M.2 SSD size.

- *Turn the M.2 board latch counterclockwise to release, and clockwise to lock.*

2. Insert your M.2 SSD into the M.2 slot at a 15-degree angle.

3. Push down the M.2 SSD till it clicks in place.

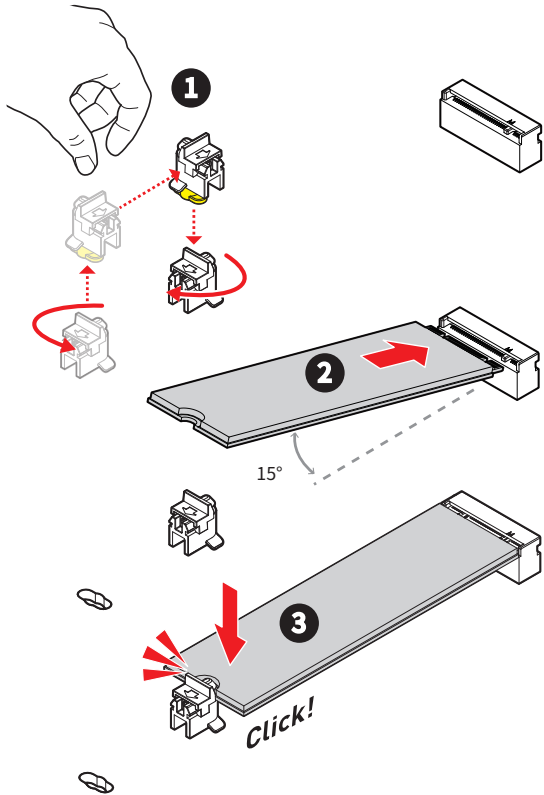

# PCIe Add-in Card

## Installing GPU Card

1. Loosen the screws on the riser bracket to remove the **filler panels**.
2. Attach the **mounting bracket** to the GPU card by tightening the screws.
3. Align the GPU card with the connector, and insert it until it is fully seated.
4. Tighten the **screws** to securely fix the card in place.
5. Connect the GPU power cable.

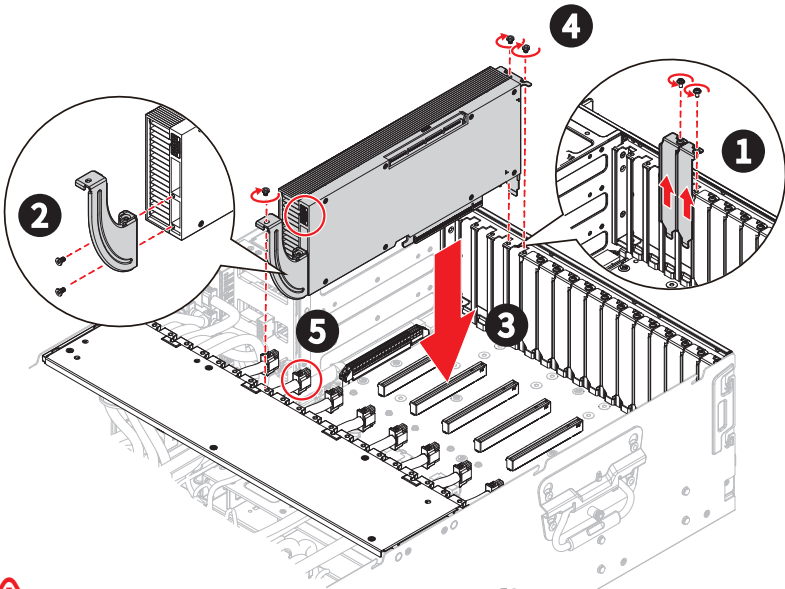

### **Important**

After connecting the power cable to the GPU card, **route the excess cable length straight back into the cable tray**. Ensure there is **no unnecessary slack or looping** within the chassis to prevent interference with airflow and maintain proper cooling.

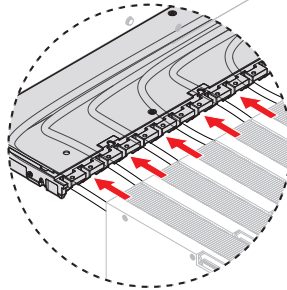

## Installing NIC Card

1. Loosen the screws on the riser bracket to remove the **filler panel**.
2. Align the NIC card with the connector, and insert it until it is fully seated.
3. Tighten the **screws** to securely fix the card in place.
4. Connect the data and power cables to the card.

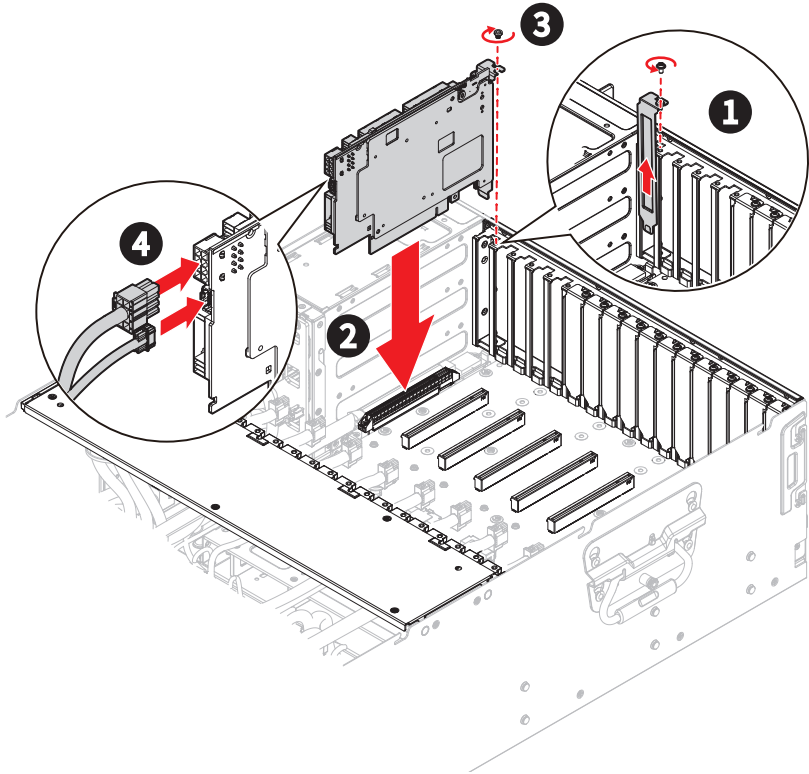

# Power Supply Unit

The server system supports four power supplies that can be easily inserted and removed from the rear side of the system without the need for tools.

## **Important**

- *Power supplies must be identical and power cords should be connected.*
- *Failing to connect power supplies could result in CPU throttling.*

## Installing Power Supply Unit (PSU)

1. Slide the PSU into the chassis bay until the **release latch** snaps into place.
2. Connect the power cable to the PSU power outlet.

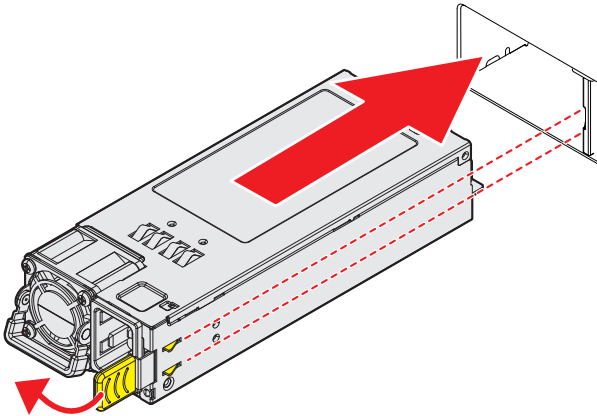

# Chassis Handle



You must remove the four chassis handles on both sides of the chassis before rack installation.

## Removing the Chassis Handle

1. Pull the plunger outward to unlock the handle.
2. Grasp the handle and pull it straight down to detach it from the chassis.
3. Remove the handle.

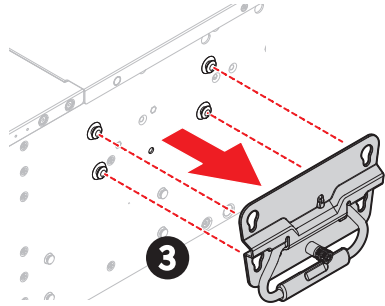
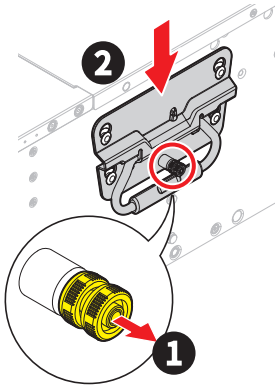

## Installing the Chassis Handle

1. Align the handle's four mounting hooks with the chassis studs and insert the handle.
2. Pull the handle firmly upward until the spring-loaded plunger automatically engages in the hole.

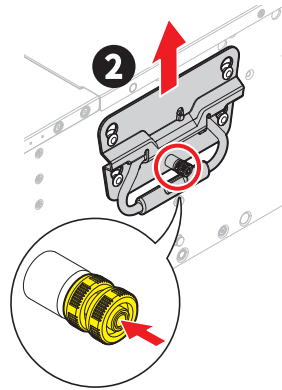
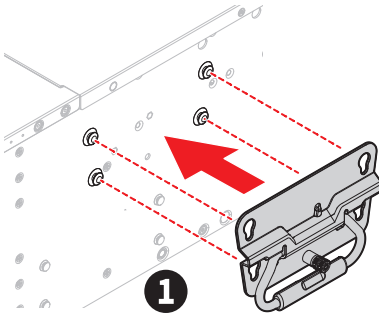

### **Important**

When the handle is assembled, please **ensure it is properly engaged** to prevent it from coming loose during handling.

# System Cable Routing

## Power Cables

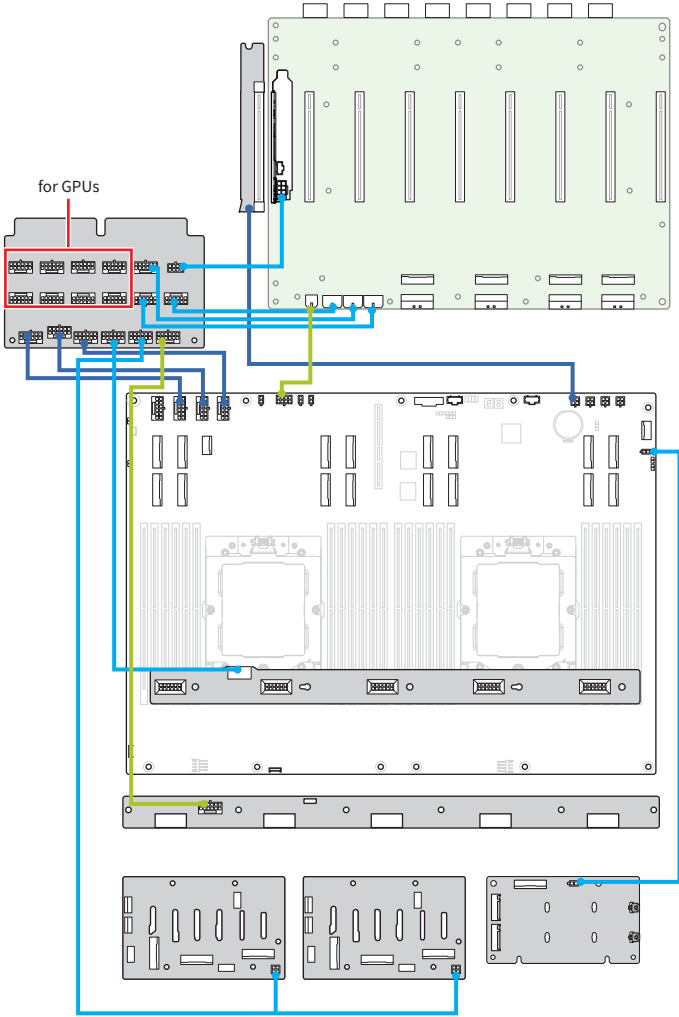

# PCIe Cables

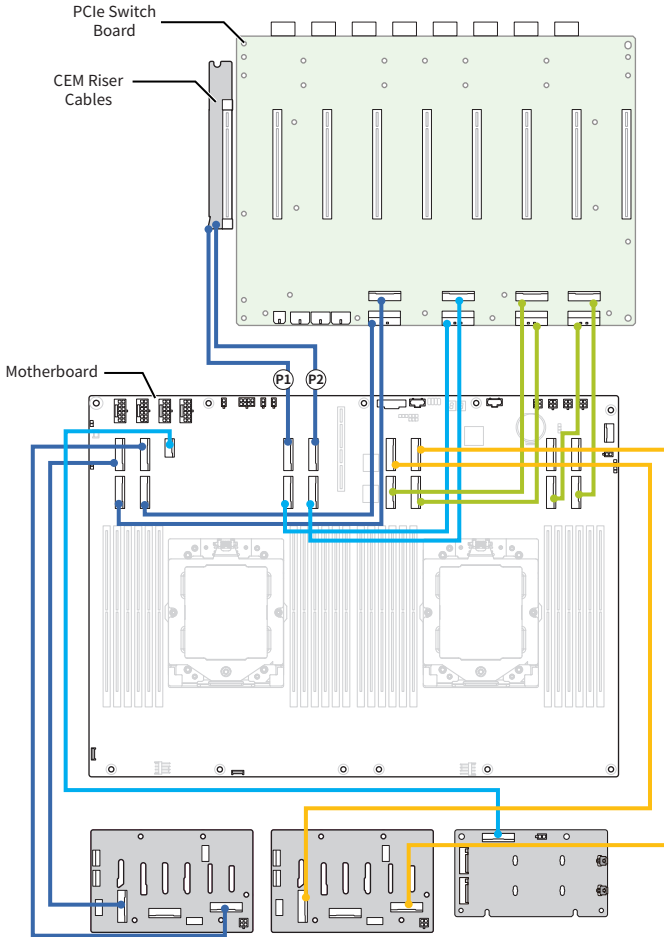
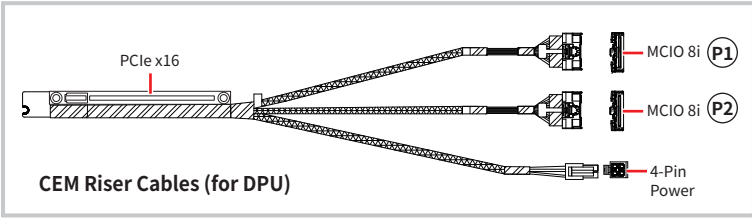

# Slide Rail

This section provides instructions for installing slide rails on your server rack to mount the server. Proper installation ensures safe and stable operation of the equipment. Follow the steps below carefully to avoid injury or damage.

## Prerequisites

- **Rack Space:** Ensure sufficient rack units (RU) are available for the server and slide rails.
- **Personnel:** At least **two people** is required for safe handling and installation. (If the installation is above chest height, a third person may be needed for proper alignment.)



### **Important**

*In order to install the system in a rack, **it is necessary to remove the four chassis handles** located on both sides of the system. (See [“Removing the Chassis Handle”](#).)*



### **Stability Hazard**

***The rack may tip over, causing serious injury or damage due to improper handling or overloading.***

- *Read the installation instructions carefully before extending the rack to the installation position.*
- *Do not place any load on the equipment when it is extended on the slide rails.*
- *Do not leave equipment extended on the slide rails unattended or for prolonged periods.*

# Installing and Removing the Slide Rail

## King Slide® — U9DJ-700

1-1) Remove the inner rail.

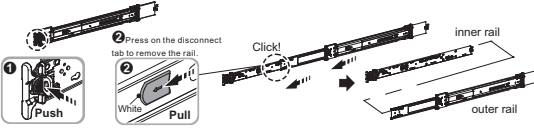

1-2) Rotate (a) and slide middle rail back.

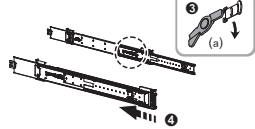

2) Install the inner rail onto the chassis. (This rail kit can be installed forward and reversely.)

1) Key Hole

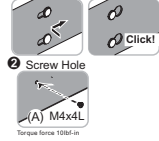

Detach Inner Rail From Standoff

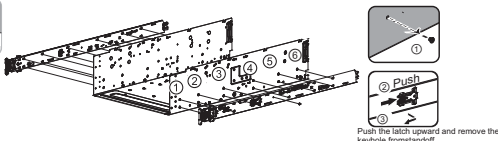

3) Fix the outer rail/bracket assembly to the frame.

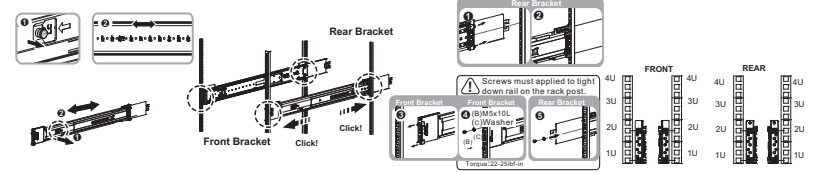

4) Insert the chassis to complete the installation.

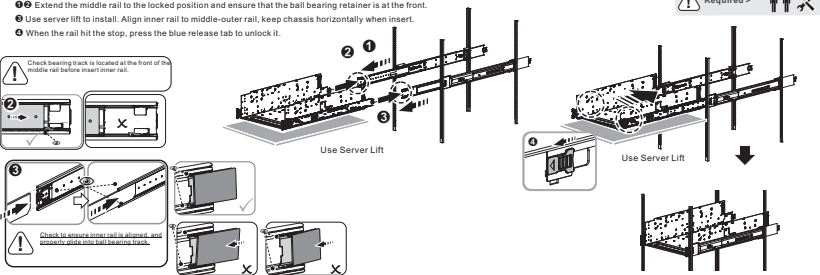

Remove the chassis from rack

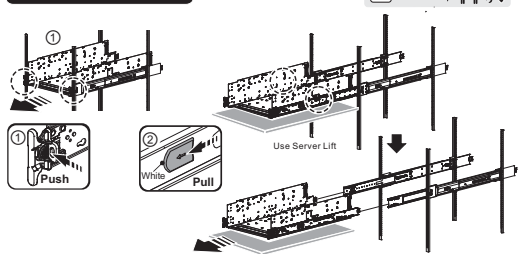

Detach Bracket From Rack Post

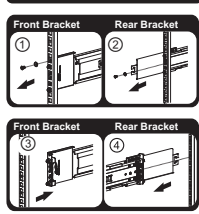

TBD

Copyright © 2025 King Slide. All Rights Reserved



[MSI.COM](https://www.msi.com)



[EPS.MSI.COM](https://www.msi.com/eps)